



Live Center System

E01 Light Duty Live Center



VPC-MT1, MT2, MT3, MT4, MT5

E01 Live Lathe Center -A Type



VLC-212, 213, 214, 215

E01 Live Lathe Center -A Type



VLC-212, 213, 214, 215

E01 Live Lathe Center -B Type



VLC-213B

E01 Live Lathe Center -B Type



VLC-214B

E02 High-Speed NC Live Center-A Type



VLC-MT3A, MT4A, MT5A, MT6A

E02 High-Speed NC Live Center-B Type



VLC-MT3B, MT4B, MT5B

E02 High-Load NC Live Center-A Type



VCF-MT3A, MT4A, MT5A

E02 High-Load NC Live Center-B Type



VCF-MT3B, MT4B, MT5B

E02 High-Load NC Live Center-B Type



VCF-MT3B, MT4B, MT5B

E03 Inter-changeable Points Live Center



VLC-312, 313, 314

E03 Inter-changeable Points Live Center



VLC-312, 313, 314

E03 High Speed NC Interchangeable Points Live Center



VCS-MT3, MT4, MT4P, MT5P

E04 High Load Interchangeable Points Live Center



VCP-MT4, MT5

E04 High Load Interchangeable Points Live Center



VCP-MT4, MT5

E04 High Speed Live Center-A Type

NEW



VLC-512, 513, 514, 515

E04 High Speed Live Center-A Type

NEW



VLC-512, 513, 514, 515

E04 High Speed Live Center-B Type

NEW



VLC-513B, 514B, 515B

E04 High Speed Live Center-B Type



VLC-513B, 514B, 515B

E04 High Speed Live Center-B Type



VLC-513B, 514B, 515B

Lathe Center System

E05 Bull Nose Pipe Center



VLC-

E05 Bull Nose Pipe Center



VLC-

E05 Bull Nose Pipe Center



VLC-

E06 Lathe Centers

NEW



VLC-117-119

E06 Lathe Centers

NEW



VLC-117-119

E06 Lathe Centers

NEW



VLC-112, 113, 114, 115, 116

E06 Dead center

NEW



VLC-112, 113, 114, 115, 116

E07 Work-Driving Center



VDK-32-MT4

E07 Work-Driving Center



VDK-23-MT4

E07 Work-Driving Center



VDK-15-MT4

E07 Work-Driving Center-Changeable Tips



VDC-30-MT4

E08 Inter-Changeable Point Rolling Center

NEW



VLC-612, 613, 614, 615

E08 Inter-Changeable Point Rolling Center

NEW



VLC-612, 613, 614, 615

E08 Live Lathe Center

NEW



VLC-172, 173, 174, 175

E08 Live Lathe Center

NEW



VLC-172, 173, 174, 175



Centering Chuck System

E09 3 Jaw Self Centering Chuck



VSC-3A ~ 25A

E09 3 Jaw Powerful Self Centering Chuck



VSK-6A, 8A, 10A, 12A, 13A, 16A

E10 4 Jaw Self Centering Chucks



VPS-6A, 7A, 8A, 10A, 12A

E10 4 Jaw Self Centering Chucks (2-Pices Jaw)



VPS-6AK, 8AK, 10AK, 12AK

E11 3 Jaw Strong Scroll Chucks D1 Camlock Direct Mounting



LD5-8,6-8

E11 3 Jaw Powerful Camlock Type Self-Centering Chuck



VSKC-6A, 8A, 10A, 12A

E12 DIN-Type 3-Jaw Self-Centering Chucks



VSC-3D ~ 10D

E12 4-Jaw Independent Chuck Plain Back



VKC-4 ~ 50

E13 3-Jaw Scroll Chuck

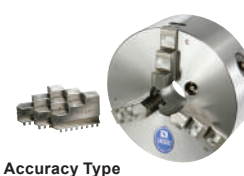

Accuracy Type

VSC-3 ~ 16

E14 3-Jaw Powerful Scroll Chuck



Accuracy Type

VSK-4 ~ 16

Thin Chuck

E16 Machining Jaw Chuck



VMJ-6, 8, 10, 12

E16 Super Thin Chucks



VNBK-6, 8, 10, 12

E17 Vertical Machining Chuck



VMJ-150, 200, 250, 300

E17 Vertical Machining Chuck



VMJ-150, 200, 250, 300

E17 Vertical Machining Chuck



VMJ-150, 200, 250, 300

Power Chuck

E18 Soft Jaw For SK-Type Chuck



VSJ-4 ~ 16

E18 Soft Jaw For SK-Type Chuck



VSJ-4 ~ 16

E19 Soft Jaw Hydraulic Power Chucks

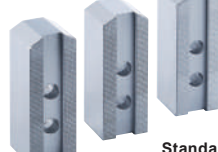

Standard

VHC-8A, 10A

E19 Soft Jaw Hydraulic Power Chucks

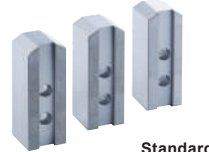

Standard

VHC-5 ~ 24

E19 Soft Jaw Hydraulic Power Chucks



Aluminium

VHC-8A, 10A

Jaw Forming

E15 6-Jaw Awl Type Chucks



VAS-4, 6

E15 Low Profile Chuck



VLBK-2,3,4,5,6

E21 Soft Jaw Forming Ring



VFR-05, 06, 08, 10, 12, 15

E21 Soft Jaw Forming Disc



VFRD-6, 8, 9, 10, 12

E31 Tool Post Grinder ON Lathe



VGR-100 ~ VGR-185

Power Chuck System

E22 T Nut For Hydraulic Chuck



B-205T, 206T, 208T, 210T, 212T

E22 Hard Jaws For Hydraulic Power Chucks



HJ-05, 06, 08, 10, 12, 12-1, 15, 15-1

E23 3-Jaw Wedge Type Through-hole Power Chuck (Without Adaptor)



N-205A4 ~ 215A11

E24 2-Jaw Wedge Type Through-hole Power Chuck (Without Adaptor)



NT205 ~ NT215

E25 3-Jaw Wedge Type Non Through-hole Power Chuck (Without Adaptor)



V-206A5 ~ 215A11

E26 Super High Speed Through Hole Rotary Hydraulic Cylinder



M1036 ~ M2511

E27 Non Through Hole Rotary Hydraulic Cylinder (With Valves)



MS105, 125, 150, 200

E27 4-Jaw Wedge Type Through-hole Power Chuck (Without Adaptor)



VNIT-208, 210, 212, 215

E28 Lathe Collet Chucks



CR42A5, 42A6, 60A6

E29 Lathe Collet



C26 / 42 / 60 / 80



VDI System

E35 Axial Drilling And Milling Heads

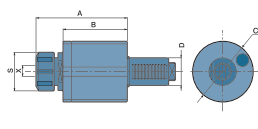

E36 Radial Drilling And Milling Heads-Back Ward Type

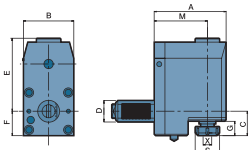

E37 Axial Drilling And Milling Heads

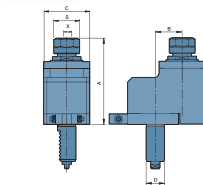

E38 Axial Drilling And Milling Heads

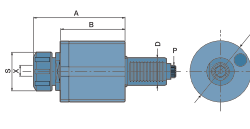

E39 Radial Drilling And Milling Heads-Backward Type

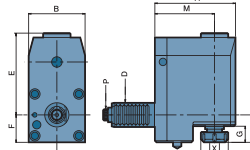

E40 Axial Drilling And Milling Heads-Offset

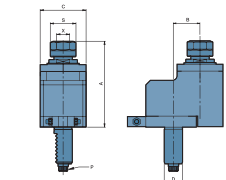

E41 Radial Double Drilling And Milling Heads

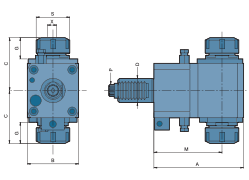

E42 Axial Drilling And Milling Heads

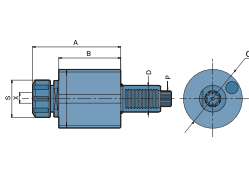

E43 Radial Drilling And Milling Heads

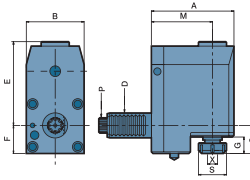

E44 Axial Drilling And Milling Heads

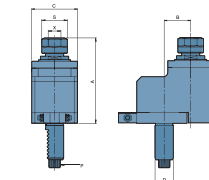

E45 Axial Drilling And Milling Heads-For "Baruffaldi" Type

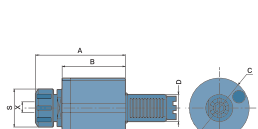

E46 Radial Drilling And Milling Heads-Backwards

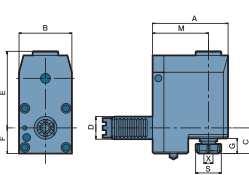

E47 Axial Drilling And Milling Heads

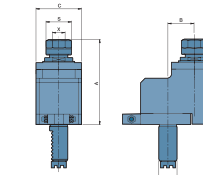

E48 Angular Heads

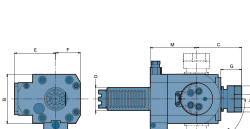

E49 Axial Drilling And Milling Heads-For "Dupomatic" Type

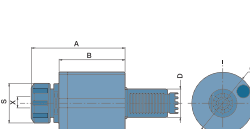

E50 Radial Drilling And Milling Heads

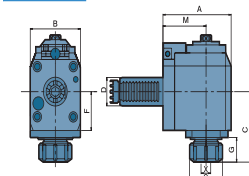

E51 Radial Drilling And Milling Heads

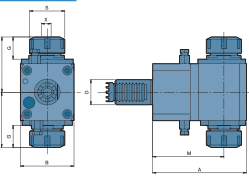

E52 Radial Static Holders

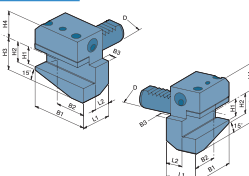

E53 Radial Static Holders

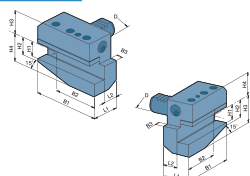

E54 Axial Static Holders

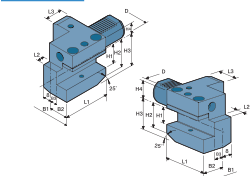

E55 Combined Static Holders

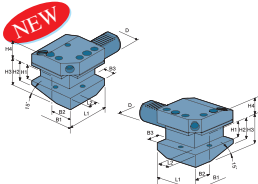

E56 Combined Static Holders

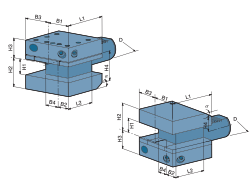

E57 Static Holders

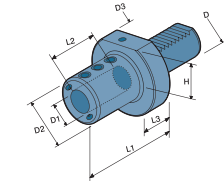

E58 Static Holders

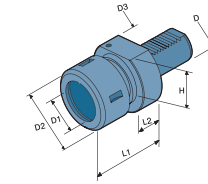

E59 Static Holders

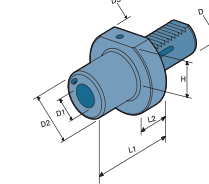

E60 Reducing Sleeves

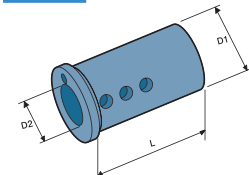

E61 Reducing Sleeves

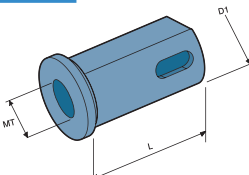

E62 H Type Milling & Drilling Head

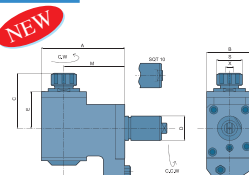

E63 H Type Milling & Drilling Head

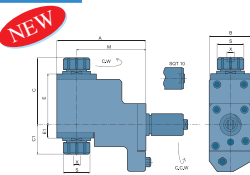

E64 V Type Milling & Drilling Head

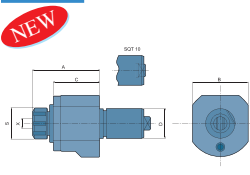

E70 U Drill Holder

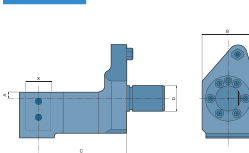

E71 Radial Drilling And Milling Heads

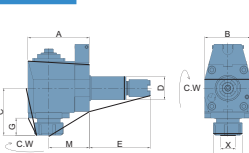

E72 Angular Heads

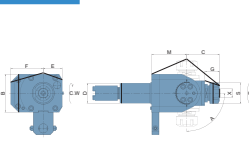

E73 Radial Milling And Drilling Head

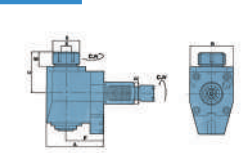

E73 Axial Milling And Drilling Head

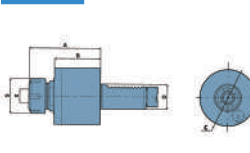



VDI System

E74 Radial Milling And Drilling Head

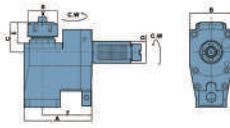

E74 Angular Heads

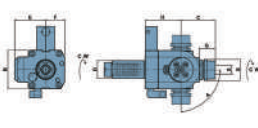

E75 Radial Milling And Drilling Head

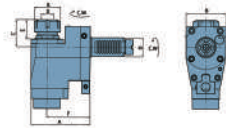

E75 Axial Milling And Drilling Head

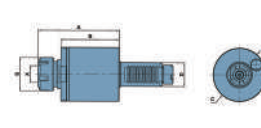

E75 Angular Heads

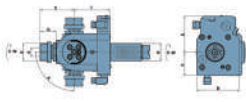

E76 Boring Bar Holder

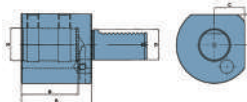

E76 Boring Bar Holder

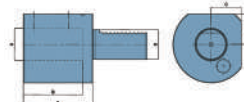

E77 Turning Holder

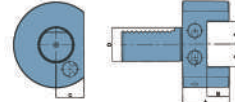

E77 Facing Holder

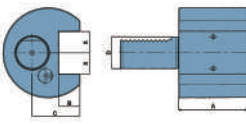

E78 Boring Bar Holder

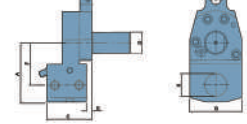

E78 Boring Bar Holder



Tool Post System

E79 Quick Change Tool Post & Holders-Italian Style



NEW

VTP-

E80 Individually Piece Italian Style



NEW

VTP-F01-

E80 Individually Piece Italian Style



NEW

VTP-F02-

E80 Individually Piece Italian Style



NEW

VTP-F03-

E80 Individually Piece Italian Style



NEW

VTP-F04-

E81 Quick Change Tool Post & Holders-40 Positioning European Style



NEW

VTP-F40-

E81 Quick Change Tool Post & Holders-40 Positioning European Style



NEW

VTP-F40-

E82 Quick Change Tool Post & Holders-40 Positioning European Style



NEW

VTP-F40-

E82 Quick Change Tool Post & Holders-40 Positioning European Style



NEW

VTP-F40-

E82 Quick Change Tool Post & Holders-40 Positioning European Style



NEW

VTP-F40-

E82 Quick Change Tool Post & Holders-40 Positioning European Style



NEW

VTP-F40-

E82 Quick Change Tool Post & Holders-40 Positioning European Style



NEW

VTP-F40-

E83 Quick Change Tool Post American Type



NEW

VTP-F50-

E84 Quick Change Tool Post American Type



NEW

VTP-F50-

E84 Quick Change Tool Post American Type



NEW

VTP-F50-

E84 Quick Change Tool Post American Type



NEW

VTP-F50-

E84 Quick Change Tool Post American Type



NEW

VTP-F50-

E85 Quick Change Tool Post American Type



NEW

VTP-F50-

E85 Quick Change Tool Post American Type



NEW

VTP-F50-

E85 Quick Change Tool Post American Type



NEW

VTP-F50-

Light Duty Live Center

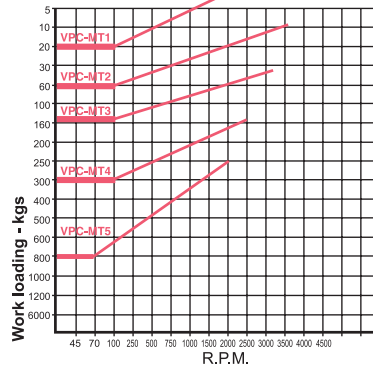
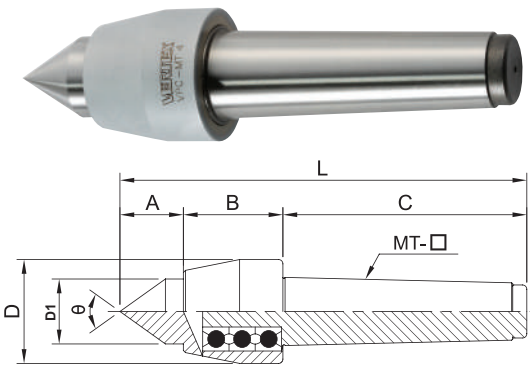

- Center is made of SCM420 alloy steel by heat treatment to provide higher rigidity (HRC60°±2°) and satisfied wear-resistance.
- Center is constituted by ball bearings assembly.
- Applicable to middle-speed & high-speed lathe with light load.

※Suggested tailstock pressure under 6 kg/cm²

FOR VPC-TYPE

Unit:mm

ORDER NO.	A	B	C	D	D1	L	Accuracy	Speed Max R.P.M.	θ	G.W. weight kgs	PACKING LxWxH	CODE NO.
VPC-MT1	21	31	56	32	16	108	0.005	3200	60°	0.3	115 x 136 x 38	5001-001
VPC-MT2	26	37	69	40	22	132	0.005	2800	60°	0.5	140 x 45 x 45	5001-002
VPC-MT3	32	46	86	45	26	164	0.005	2000	60°	0.9	170 x 50 x 52	5001-003
VPC-MT4	34	46	108	48	30	188	0.005	1800	60°	1.3	195 x 58 x 56	5001-004
VPC-MT5	50	62	136	68	45	248	0.005	1500	60°	3.2	268 x 86 x 77	5001-005

Live Lathe Center



A TYPE

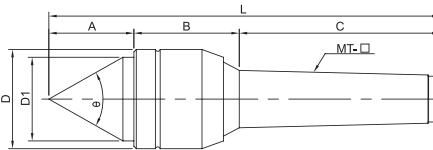

B TYPE

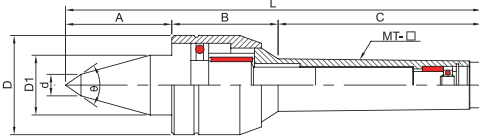

- Center shaft & main body is made of SCM420 alloy steel by heat treatment to provide higher rigidity (HRC60°±2°) and satisfied wear-resistance.
- Center is constituted by thrust ball bearing, needle roller bearings & ball bearings assembly.
- Applicable to middle-speed & high-speed lathe with heavy load.

※ B TYPE SUITABLE FOR SMALL -WORKPIECE MACHINING.

※Suggested tailstock pressure under 6 kg/cm²

Unit:mm

ORDER NO.	TYPE	A	B	C	D	D1	d	L	Accuracy	Speed Max R.P.M.	θ	G.W. weight kgs	PACKING LxWxH	CODE NO.
VLC-212	MT2A	28	35	69	32	23	-	132	0.005	4000	60°	0.3	173 x 43 x 40	5001-010
VLC-213	MT3A	36	44	86	41	35	-	166	0.005	3000	60°	0.9	198 x 67 x 51	5001-011
VLC-214	MT4A	41	51	108	47	40	-	200	0.005	2500	60°	1.5	240 x 70 x 61	5001-012
VLC-215	MT5A	54	72	136	65	52	-	262	0.005	2000	60°	3.8	290 x 92 x 80	5001-013
VLC-213B	MT3B	46	44	86	41	25	10	176	0.005	3000	60°	0.9	198 x 67 x 51	5001-014
VLC-214B	MT4B	55	51	108	47	32	12	214	0.005	2500	60°	1.5	240 x 70 x 61	5001-015

THE CHART FOR LOADING WEIGHT WITH R.P.M.

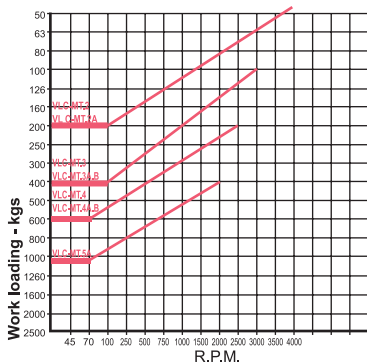

FOR VLC-TYPE

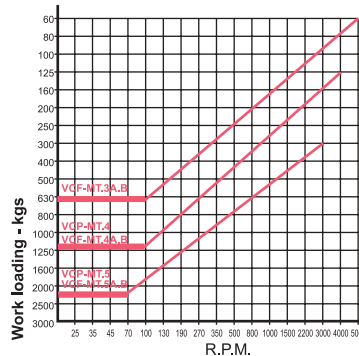

FOR VCF/VCP-TYPE

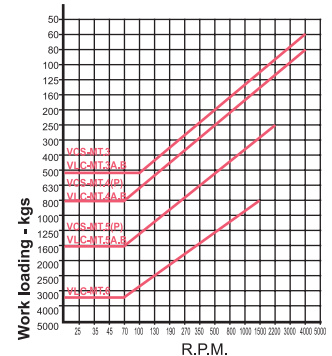

FOR VCS-TYPE



A TYPE

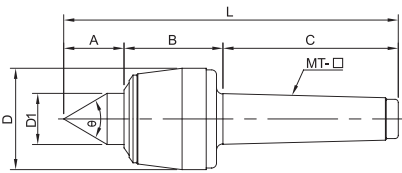

B TYPE

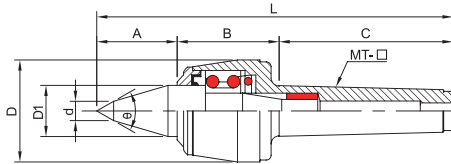

WATER-PROOF TYPE

- Center shaft is made of SUJ2 material under vacuum heat treatment to provide higher rigidity (HRC60°±2°) and satisfied wear-resistance.
 - Center is constituted by dual ball bearing. Thrust bearing & needle roller bearing assembly.
 - Applicable to high-speed lathe & NC lathe with heavy load
 - water-proof.
- ※ B Type is applicable in the metal workings on small diameter workpieces.

※Suggested tailstock pressure under 6 kg/cm²

Unit:mm

ORDER NO.	TYPE	A	B	C	D	D1	d	L	Accuracy	Speed Max R.P.M.	θ	G.W. weight kgs	PACKING LxWxH	CODE NO.
VLC-MT3A	MT3A	39	51	86	53	30	-	176	0.005	4000	60°	1.3	240 x 70 x 61	5001-020
VLC-MT4A	MT4A	42	62	108	63	32	-	212	0.005	3000	60°	2.2	253 x 92 x 80	5001-021
VLC-MT5A	MT5A	57	71	136	83	40	-	264	0.005	2500	60°	4.5	303 x 108 x 101	5001-022
VLC-MT6A	MT6A	80	111	189	128	70	-	380	0.008	1500	60°	15.6	410 x 177 x 168	5001-023
VLC-MT3B	MT3B	48	52	86	53	30	10	186	0.005	4000	60°	1.4	240 x 70 x 61	5001-024
VLC-MT4B	MT4B	52	62	108	63	32	12	218	0.005	3000	60°	2.2	253 x 92 x 80	5001-025
VLC-MT5B	MT5B	67	71	136	83	40	14	274	0.005	2500	60°	4.5	303 x 108 x 101	5001-026



High-Load NC Live Center



A TYPE

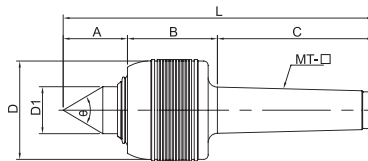

B TYPE

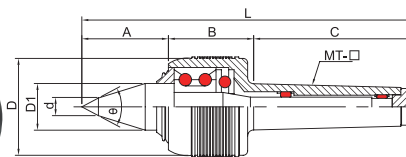

- Shaft uses material SUJ2: through vacuum heat treatment, it is even more durable, hardness is as high as (HRC60°±2°) and satisfied wear-resistance.
 - Front end is constituted by angular contact ball bearing & thrust ball bearing. middle & rear ends are comprised of needle roller bearing assembly.
 - These centers are suitable for NC lathe at high-speed & heavy-load operation, water-proof.
- ※ B Type is applicable in the metal workings on small workpieces.

※Suggested tailstock pressure under 6 kg/cm²

Unit:mm

ORDER NO.	A	B	C	D	D1	d	L	Accuracy	Speed Max R.P.M.	θ	G.W. weight kgs	PACKING LxWxH	CODE NO.
VCF-MT3A	38	50	86	53	30	-	174	0.003	5000	60°	1.3	240 x 70 x 61	5001-030
VCF-MT4A	45	60	108	68	32	-	213	0.003	4500	60°	2.4	253 x 92 x 80	5001-031
VCF-MT5A	52	70	136	87	40	-	258	0.003	3000	60°	5	303 x 108 x 101	5001-032
VCF-MT3B	52	50	86	53	25	10	188	0.003	5000	60°	1.3	240 x 70 x 61	5001-033
VCF-MT4B	55	60	108	68	32	12	223	0.003	4500	60°	2.4	253 x 92 x 80	5001-034
VCF-MT5B	67	70	136	87	40	14	273	0.003	3000	60°	5	303 x 108 x 101	5001-035

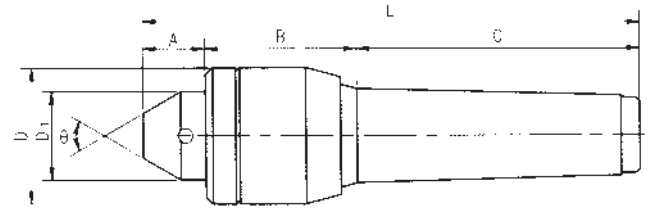

Inter-changeable Points Live Center

**VERTEX®**

- Complete set with 7 Interchangeable Points for various processing.
- Packed in case.
- High accuracy and durability as well as complete rust-proof performance
- Center made of SCM420 special tool steel hardened and ground can be used for heavy duty work.

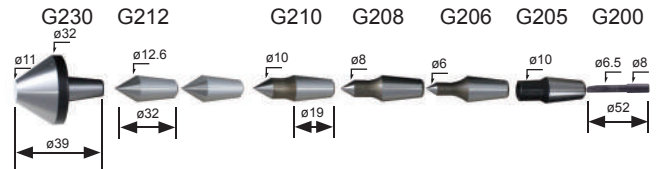
*Suggested tailstock pressure under 6 kg/cm²

Unit:mm

ORDER NO.	TYPE	A	B	C	D	D1	L	Accuracy	Speed Max. R.P.M.	θ	G.W. weight kgs	PACKING LxWxH	CODE NO.
VLC-312	MT2	22	36	69	32	25	127	0.008	4000	60°	0.9	166 x 105 x 63	5001-040
VLC-313	MT3	23	44	86	41	30	153	0.008	3000	60°	1.4	255 x 138 x 100	5001-041
VLC-314	MT4	23	51	108	47	32	182	0.008	2500	60°	2	255 x 138 x 100	5001-042



High Speed NC Interchangeable Points Live Center

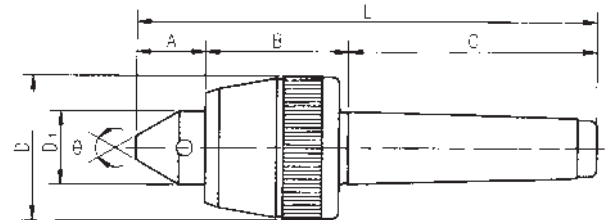

VCS-MT3, MT4

VCS-MT4P, MT5P

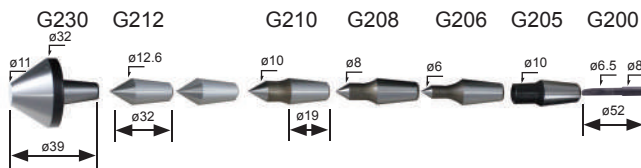

- Center shaft is made of SUJ2 material under vacuum heat treatment to provide higher rigidity (HRC60°±2°) and satisfied wear-resistance.
- Center is constituted by dual ball bearing. Thrust bearing & needle roller bearing assembly.
- Suit for to high-speed lathe & NC lathe with heavy load, water-proof.

*Suggested tailstock pressure under 6 kg/cm²

Unit:mm

ORDER NO.	A	B	C	D	D1	L	Accuracy	Speed Max. R.P.M.	θ	G.W. weight kgs	PACKING LxWxH	CODE NO.
VCS-MT3	28	51	86	53	30	165	0.008	4000	60°	1.8	255 x 138 x 100	5001-050
VCS-MT4	30	62	108	63	32	196	0.008	3500	60°	2.5	255 x 138 x 100	5001-051
VCS-MT4P	30	62	108	63	32	196	0.008	3500	60°	2.7	235 x 130 x 80	5001-052
VCS-MT5P	34	71	136	83	40	237	0.008	2500	60°	5.1	275 x 147 x 97	5001-053



High Load Interchangeable Points Live Center

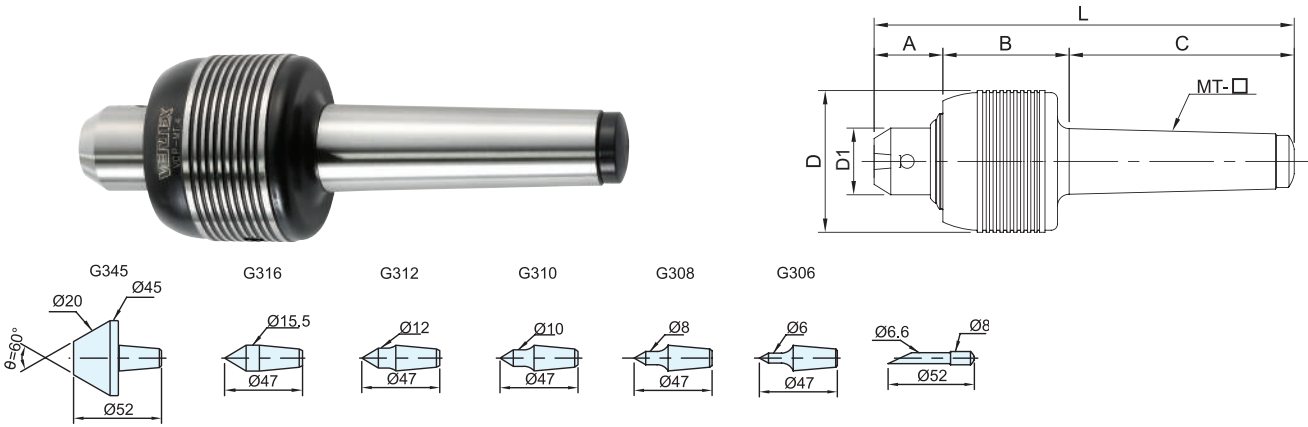

- Shaft uses material SUJ2:through vacuum heat treatment, it is even more durable, hardness is as high as (HRC60°±2°) and satisfied wear-resistance.
- Front end is constituted by SKF angular contact ball bearing & thrust ball bearing. middle & rear ends are comprised of needle roller bearing assembly.
- These centers are suitable for NC lathe at high-speed & heavy-load operation, water-proof.

※Suggested tailstock pressure under 6 kg/cm²

Unit:mm

ORDER NO.	A	B	C	D	D1	L	Accuracy	Speed Max. R.P.M.	θ	G.W. weight kgs	PACKING LxWxH	CODE NO.
VCP-MT4	30	64	108	68	32	202	0.005	4500	60°	3	253 x 130 x 80	5001-060
VCP-MT5	37	70	136	87	40	243	0.005	3000	60°	5.5	275 x 147 x 97	5001-061



High Speed Live Center



EURO STYLE



A TYPE



B TYPE

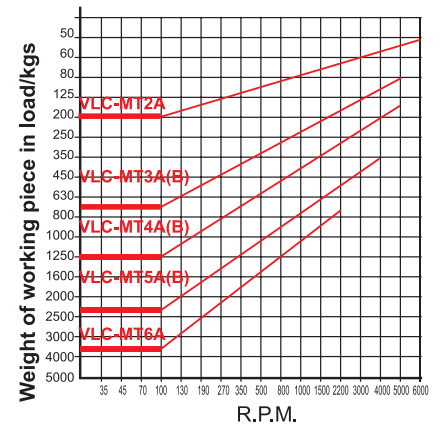
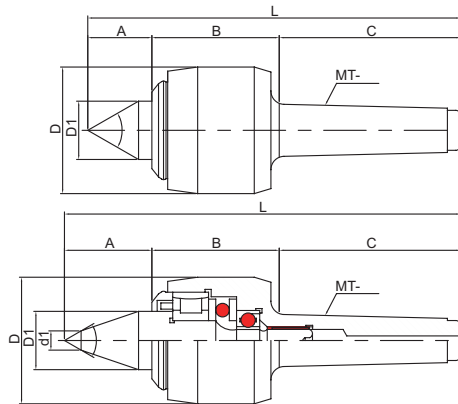

- Suit for to CNC lathes, can be used at high speed turning and with waterproof design.
 - The shaft is made of alloy steel and through vacuum heat treatment HRC 60°±2°. It has high rigidity and high durability.
 - The center uses the combination of roller bearing, thrust ball bearing and ball bearing.
- ※B Type is applicable in the metal workings on small workpieces.

※Suggested tailstock pressure under 6 kg/cm²

Unit:mm

ORDER NO.	TYPE	A	B	C	D	D1	L	d1	Accuracy	Speed Max. R.P.M	θ	G.W. weight	PACKING L x W x H	CODE NO.
VLC-512	MT2A	20	46	69	32	13	135	-	0.003	6000	60°	0.8	240x70x61	5001-062
VLC-513	MT3A	34	61	86	58	25	181	-	0.003	5200	60°	1.8	253x92x80	5001-063
VLC-514	MT4A	44	67	114	76	35	225	-	0.003	5000	60°	3.2	290x92x80	5001-064
VLC-515	MT5A	55	88	142	95	45	285	-	0.003	3500	60°	5.6	303x108x101	5001-065
VLC-513B	MT3B	45	61	86	58	25	192	10	0.003	5200	60°	1.8	290x92x80	5001-067
VLC-514B	MT4B	55	67	114	76	35	236	12	0.003	5000	60°	3.2	253x92x80	5001-068
VLC-515B	MT5B	67	88	142	95	45	297	14	0.003	3500	60°	6.0	303x108x101	5001-069



HARDEN PROCESS : HRC50°
 CONCENTRICITY : 0.005mm
 ROUNDNESS : 0.005mm
 MATERIAL : STEEL

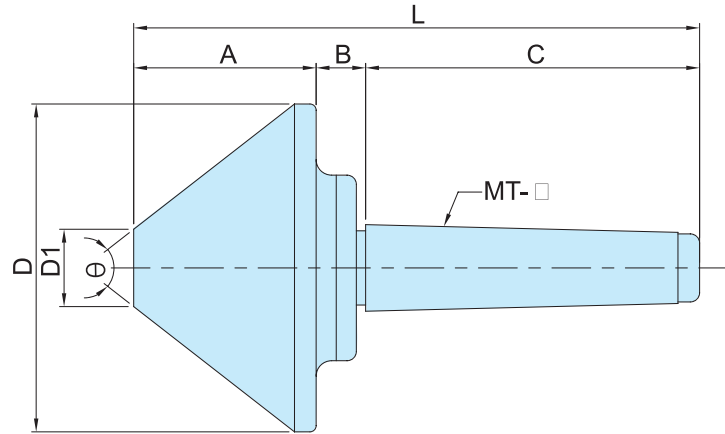

※Suggested tailstock pressure under 6 kg/cm²

Unit:mm

ORDER NO.	SIZE MTxD	A	B	C	D	D1	L	Speed Max. R.P.M	θ	R.P.M 100 LOAD WEIGHT (KGS)	G.W. weight (KGS)	CODE NO.
VLC-422	MT2×2 1/2"	48	12	69	63.5	12	128	3000	60°	200	0.9	5001-070A
VLC-423	MT2×3"	56	12	69	78	19	138	2500	60°	400	1.3	5001-070B
VLC-424	MT2×4"	58	12	69	106	32	141	2000	70°	640	2.3	5001-070C
VLC-433	MT3×3"	52	18	86	78	19	156	3300	60°	400	1.6	5001-070
VLC-434	MT3×4"	59	16	86	106	32	161	3000	70°	500	2.8	5001-071
VLC-435	MT3×5"	71	12	89	128	35	173	1900	70°	960	4.2	5001-071A
VLC-436	MT3×6"	81	12	89	156	50	183	1900	70°	1200	7.3	5001-071B
VLC-443	MT4×3"	52	18	108	78	19	178	3300	60°	400	1.8	5001-072
VLC-444	MT4×4"	59	16	108	106	32	183	3000	70°	500	3.1	5001-073
VLC-445	MT4×5"	73	12	108	128	35	193	2000	70°	650	4.9	5001-074
VLC-446	MT4×6"	88	12	108	156	50	208	1900	70°	800	7.7	5001-075
VLC-448	MT4×8"	98	12	108	206	54	218	1500	75°	1300	15.4	5001-076
VLC-4410	MT4×10"	107	13	110	258	92	236	1000	80°	2000	24	5001-076A
VLC-454	MT5×4"	58	12	143	106	32	214	2000	70°	640	4	5001-077A
VLC-455	MT5×5"	73	12	136	128	35	221	2000	70°	650	5.8	5001-077
VLC-456	MT5×6"	88	12	136	156	50	236	1900	70°	800	8.6	5001-078
VLC-458	MT5×8"	98	12	136	206	54	246	1500	75°	1600	15.7	5001-079
VLC-4510	MT5×10"	107	13	143	258	92	264	1000	80°	2200	25.5	5001-079A
VLC-4512	MT5×12"	110	25	143	306	120	281	1000	90°	3000	37.5	5001-079B
VLC-466	MT6×6"	81	12	185	156	50	281	1900	70°	1200	12	5001-080A
VLC-468	MT6×8"	103	13	185	206	54	298	1500	75°	2000	15.8	5001-080
VLC-4610	MT6×10"	107	13	185	258	92	306	1000	80°	2500	28	5001-081
VLC-4612	MT6×12"	110	25	185	306	120	323	1000	90°	3000	40	5001-082



Lathe Center



- Half diameter
- High precision
- Carbide tip
- DIN 806

NEW

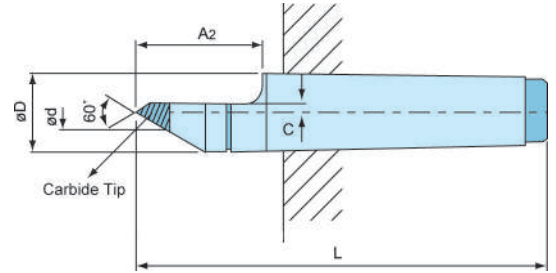

※Suggested tailstock pressure under 6 kg/cm²

ORDER NO.	SIZE	A2	C	ØD	Ød	L	Weight (kgs)	CODE NO
VLC-117	MT3	41	3	24	9	124	0.33	5001-086
VLC-118	MT4	54	4	31.3	11.5	158	0.72	5001-087
VLC-119	MT5	69	4.5	44.5	13	198	1.73	5001-088



Lathe Center

- K20 Carbide tipped-HRC 70°
- Hardened & precision ground.
- Concentricity within.0002"(0.005mm)
- DIN806

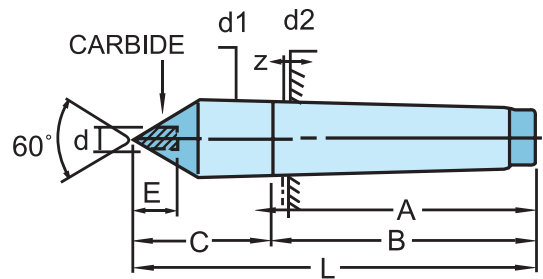

※Suggested tailstock pressure under 6 kg/cm²

ORDER NO.	SIZE	A	B	C	E	L	d2	d1	d	Weight (kgs)	CODE NO.
VLC-112	MT-2	69	67	31	8	100	17.780	18.0	6	0.2	5001-090
VLC-113	MT-3	89	81	39	10	125	23.825	24.1	8	0.4	5001-091
VLC-114	MT-4	109	102.5	46	14	155	31.267	31.6	10	0.8	5001-092
VLC-115	MT-5	136	129.5	64	18	200	44.399	44.7	14	2.1	5001-093
VLC-116	MT-6	190	182	80	30	270	63.648	63.8	18	5.7	5001-094

Unit:mm

LATHE CENTER



Dead Center

- Suit for lathe & grinding machine
- Hardened & precision ground
- DIN806

NEW

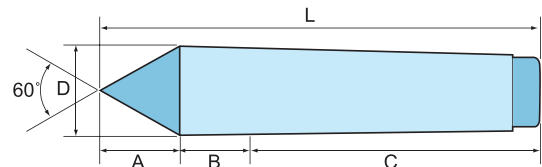
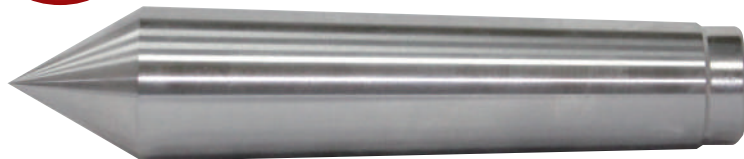

※Suggested tailstock pressure under 6 kg/cm²

ORDER NO.	SIZE	A	B	C	D	L	Weight (kgs)	CODE NO
VLC-126	MT2	18	7	75	19	100	0.16	5001-111
VLC-127	MT3	24	10	91	25	125	0.34	5001-112
VLC-128	MT4	30	11	114	32	155	0.73	5001-113
VLC-129	MT5	39	16	145	46	200	1.9	5001-114
VLC-130	MT6	54	29	187	64	270	5.12	5001-115



VDK-15



VDK-23



VDK-32

- This Clamp-free center is comprised of excellent mechanical structure, nearly free of breakdown. main body & center shaft are made of SLD material by heat treatment(HRC62°). Driving is required for traditional lathe machining to prevent workpiece from stop.
- This clamp-free center with 6 T & 8T design on end surface is able to securely support workpiece surface to fulfill easy and rapid machining.

※Suggested tailstock pressure under 6 kg/cm²

Unit:mm

ORDER NO.	Center Shaft Size	Outer Dia	Working Range	Weight (KGS)	CODE NO.
VDK-15-MT4	6ø	16ø	16ø-25ø	0.6	5001-100
VDK-23-MT4	8ø	23ø	23ø-32ø	0.7	5001-101
VDK-32-MT4	8ø	32ø	32ø-45ø	0.7	5001-102

Work-Driving Center-Changable Tips



SET STYLE



TAPER SLEEVE



STOPPER



CENTER



※Suggested tailstock pressure under 6 kg/cm²

Unit:mm

ORDER NO.	Center Shaft Size	Stopper Outer Dia	Working Range	Weight (KGS)	CODE NO.
VDC-30-MT4	6ø, 8ø, 10ø	16ø, 23ø, 30ø	15ø-45ø	2.63	5001-106



Inter-Changeable Point Rolling Center VERTEX®

Economical Type

NEW

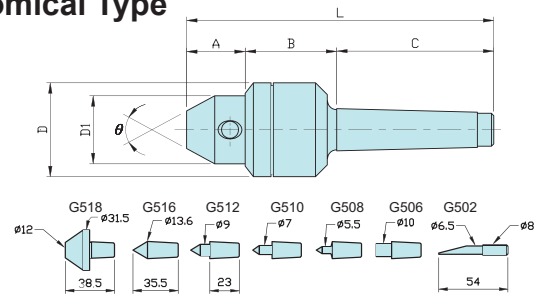

- 7 points / set
- Concentricity : $\pm 0.008\text{mm}$
- With high grade bearing

※Suggested tailstock pressure under 6 kg/cm^2

Unit:mm

ORDER NO.	TYPE	A	B	C	D	D1	L	Accuracy	Speed Max R.P.M.	θ	G.W. Weight Kgs	CODE NO.
VLC-612	MT2	24	39	69	40	29	132	0.005	1800	60°	0.85	5001-121
VLC-613	MT3	24	43	91	46	30	158	0.005	1600	60°	1.1	5001-122
VLC-614	MT4	24	44	107	48	32	175	0.005	1600	60°	1.4	5001-123
VLC-615	MT5	25	64	138	63.5	35	227	0.005	1000	60°	3.8	5001-124



Live Lathe Center

NEW

LIGHT DUTY



CARBIDE

※Suggested tailstock pressure under 6 kg/cm^2

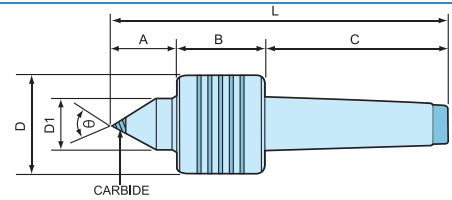

- K20 carbide tipped, HRC 70°
- Hardened & precision ground
- Concentricity : $0.0002'' (\pm 0.005\text{mm})$

ORDER NO.	TYPE	A	B	C	D	D1	L	SPEED MAX. R.P.M.	θ	WORK LOADING-KGS	G.W. weight kgs	CODE NO
VLC-172	MT2	32	40	72	41	25	144	2300	60°	60	0.55	5001-131
VLC-173	MT3	34	45	88	45	30	167	2000	60°	160	0.84	5001-132
VLC-174	MT4	34	45	109	45	30	188	1800	60°	300	1.15	5001-133
VLC-175	MT5	50	61	134	68	45	245	1500	60°	800	3.3	5001-134



Drill Chucks Arbor



SLEEVE



MT3.4.5
-JT-

ARBOR

SLEEVE

Please see page C43,C44,C56,C57

ORDER NO.	I.D.xO.D.	D	d	L	l1	l2	kg	CODE NO.
VQ-101	MT2xMT3	23.825	17.780	112	18	67	0.2	3210-001
VQ-102	MT2xMT4	31.267	17.780	124	6.5	67	0.5	3210-002
VQ-103	MT2xMT5	44.399	17.780	156	6.5	67	1.4	3210-003
VQ-104	MT2xMT6							3210-004
VQ-105	MT3xMT4	31.267	23.825	140	22.5	84	0.4	3210-005
VQ-106	MT3xMT5	44.399	23.825	156	6.5	84	1.3	3210-006
VQ-107	MT3xMT6	63.348	23.825	218	8	84	4	3210-007
VQ-108	MT4xMT5	44.399	31.267	171	21.5	107	1	3210-008
VQ-109	MT4xMT6	63.348	31.267	218	8	107	3.7	3210-009
VQ-110	MT5xMT6	63.348	44.399	218	8	133	2.9	3210-010
VQ-100	MT1xMT3	23.825	12.065	100	6	55	0.2	3210-011
VQ-100-1	MT1xMT2	17.780	12.065	89	14	55	0.22	3210-012
VQ-100-2	MT1xMT4	31.267	12.065	124	6.5	55	0.89	3210-013
VQ-100-3	MT1xMT5	44.399	12.065	156	7	55	1.33	3210-014

ORDER NO.	TAPER	JT NO.	C	H	kg	CODE NO.
VJ-126	MT2	JT3	20.6	34	0.24	3209-006
VJ-126-1	MT2	B16	15.733	29	0.2	3209-006A
VJ-126-3	MT2	B18	17.78	37	0.21	3209-006B
VJ-130	MT2	JT6	17.17	28	0.22	3209-029
VJ-130-2	MT2	JT5	35.89	50	0.5	3209-029A
VJ-130-4	MT2	JT4	28.55	45	0.4	3209-029B
VJ-137	MT2	JT2	14.2	25	0.2	3209-056
VJ-131	MT3	JT6	17.17	26	0.4	3209-030
VJ-131-2	MT3	JT5	35.89	50	0.7	3209-030A
VJ-131-4	MT3	JT33	15.85	28	0.3	3209-030B
VJ-134	MT3	B16	15.733	24	0.3	3209-033
VJ-134-2	MT3	B18	17.78	37	0.4	3209-033A
VJ-138-1	MT3	JT3	20.60	34	0.35	3209-034
VJ-131-2	MT3	JT5	35.89	50	0.7	3209-030A
VJ-138-2	MT3	JT4	28.55	45	0.5	3209-035
VJ-132	MT4	JT6	17.17	26	0.7	3209-031
VJ-132-1	MT4	JT3	20.60	34	0.7	3209-031A
VJ-132-7	MT4	JT4	28.55	45	0.85	3209-031B
VJ-132-4	MT4	JT5	35.89	50	1	3209-031C
VJ-132-5	MT4	JT2	14.2	25		3209-031D
VJ-132-6	MT4	JT33	15.85	28	0.65	3209-031E
VJ-132-8	MT4	B18	17.78	37	0.7	3209-031F
VJ-135	MT4	B16	15.733	29	0.7	3209-036
VJ-133	MT5	JT6	17.17	26	1.6	3209-032
VJ-133-1	MT5	JT3	20.60	35	1.6	3209-032A
VJ-133-2	MT5	JT4	28.55	46	1.8	3209-032B
VJ-133-3	MT5	JT5	35.89	51	2	3209-032C
VJ-133-4	MT5	JT2	14.2	26	1.6	3209-032D
VJ-133-5	MT5	JT33	15.85	29	1.6	3209-032E

LATHE CENTER



3 Jaw Self Centering Chuck



2 Set of Solid Jaw. Plain Back

Normal Type

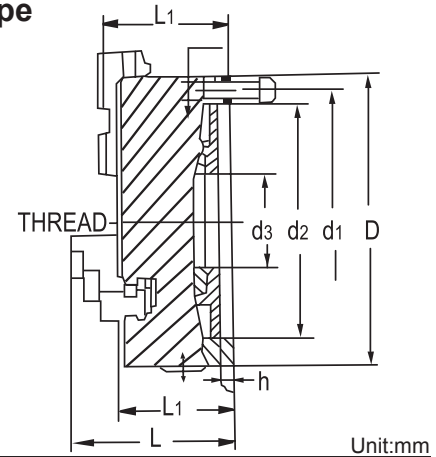
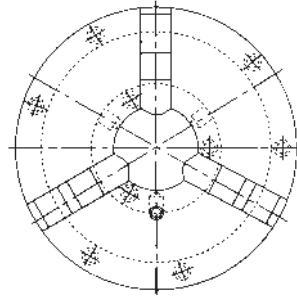

SPECIFICATIONS

ORDER NO.	D-Size	d1	d2	d3	L	L1	h	THREAD	GRIPPING RANGE		WEIGHT (kgs)	CODE NO.
									O.D. RANGE	I.D. RANGE		
VSC-3A	80mm(3")	66	55	16	66	50	3.5	3-M6	Ø2-Ø70	Ø24-Ø64	2	5002-020A
VSC-4A	100mm(4")	84	72	22	74.5	55	3.5	3-M8	Ø3-Ø90	Ø32-Ø84	3.3	5002-021A
VSC-5A	130mm(5")	115	100	30	78	55	3.5	3-M8	Ø3-Ø110	Ø35-Ø100	5.8	5002-022A
VSC-6A	160mm(6")	142	130	45	95	65	5	3-M8	Ø3-Ø160	Ø48-Ø150	9	5002-023A
VSC-7A	190mm(7 1/2")	172	155	55	105	75	5	3-M10	Ø4-Ø180	Ø56-Ø170	15.1	5002-024A
VSC-8A	200mm(8")	180	165	70	109	75	5	3-M10	Ø4-Ø180	Ø56-Ø170	15.6	5002-025A
VSC-9A	240mm(9 1/2")	215	195	70	122.5	80	5	3-M12	Ø5-Ø220	Ø62-Ø210	26	5002-026A
VSC-10A	250mm(10")	226	206	80	120	80	5	3-M12	Ø6-Ø220	Ø70-Ø250	26.5	5002-027A
VSC-12A	315mm(12")	285	260	100	147.5	90	6	3-M16	Ø10-Ø300	Ø86-Ø290	47	5002-028A
VSC-16A	400mm(16")	368	340	130	173.5	100	6	3-M16	Ø14-Ø400	Ø100-Ø380	73	5002-029A
VSC-20A	500mm(20")	465	440	210	202	115	6	3-M16	Ø25-Ø500	Ø150-Ø500	131	5002-030A
VSC-25A	630mm(25")	595	560	260	194	130	6	3-M16	Ø50-Ø630	Ø170-Ø630	200	5002-031A

Unit:mm



3 Jaw Powerful Self Centering Chuck

Reversible Top Jaws. Plain Back

Normal Type

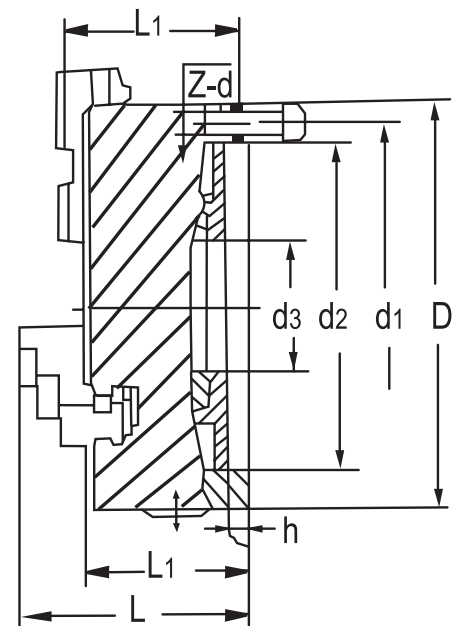
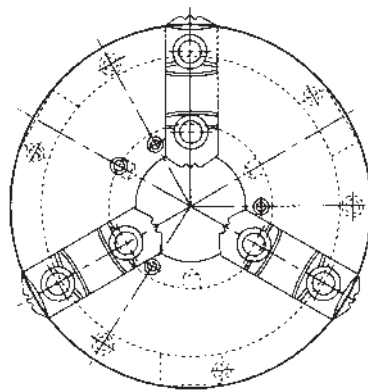

3 JAW SELF CENTERING CHUCK REVERSIBLE TOP JAWS. PLAIN BACK

SPECIFICATIONS

ORDER NO.	D-Size	d1	d2	d3	L	L1	h	THREAD	GRIPPING RANGE		WEIGHT (kgs)	CODE NO.
									O.D. RANGE	I.D. RANGE		
VSK-6A	160mm(6")	142	130	45	95	71	5	3-M8	Ø8-Ø160	Ø55-Ø150	8.3	5002-040A
VSK-8A	200mm(8")	180	165	65	109	78	5	3-M12	Ø8-Ø180	Ø62-Ø170	16	5002-042A
VSK-10A	250mm(10")	226	206	80	120	84	5	3-M12	Ø12-Ø260	Ø80-Ø250	21.7	5002-043A
VSK-12A	315mm(12")	285	260	100	156.5	102.5	6	3-M16	Ø15-Ø300	Ø90-Ø290	41	5002-043B
VSK-13A	325mm(13")	296	272	100	154.5	102.5	6	3-M16	Ø11.5-Ø350	Ø110-Ø340	45.8	5002-044A
VSK-15A	380mm(15")	350	325	130	156.5	104.5	6	3-M16	Ø11.5-Ø400	Ø110-Ø400	64.7	5002-045A
VSK-16A	400mm(16")	368	340	130	181.5	129.5	6	3-M16	Ø30-Ø470	Ø110-Ø380	75.5	5002-046A

Unit:mm



4 Jaw Self Centering Chucks

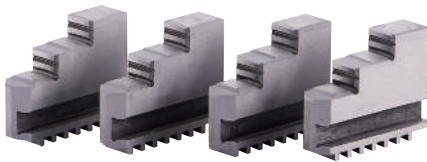
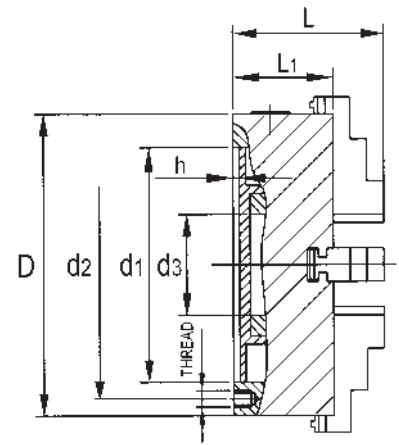
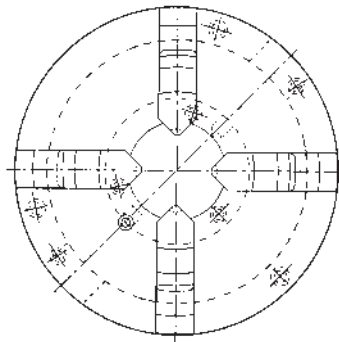

SPECIFICATIONS

Unit:mm

ORDER NO.	D	d1	d2	d3	L	L1	h	THREAD	GRIPPING RANGE		WEIGHT (kgs)	CODE NO.
									O.D. RANGE	I.D. RANGE		
VPS-6A	165	130	145	45	94	65	5	3-M8	Ø4-Ø165	Ø55-Ø150	9.3	5002-050
VPS-8A	200	165	180	65	109	75	5	3-M10	Ø4-Ø200	Ø65-Ø200	16.6	5002-052
VPS-10A	250	206	226	80	120	80	5	3-M12	Ø6-Ø250	Ø90-Ø250	28	5002-053
VPS-12A	315	260	285	100	147.5	90	6	3-M16	Ø10-Ø315	Ø100-Ø315	54	5002-054



4-Jaw Self Centering Chucks (2-Pieces Jaw)

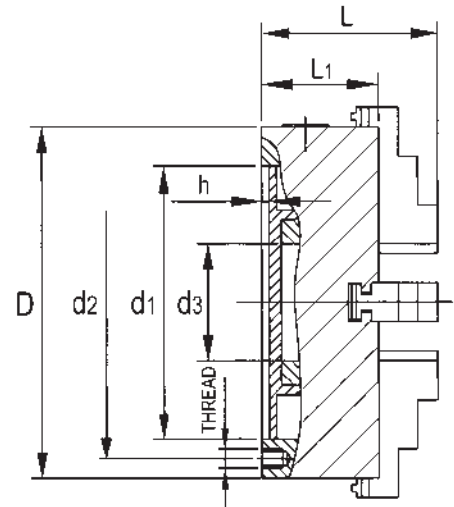
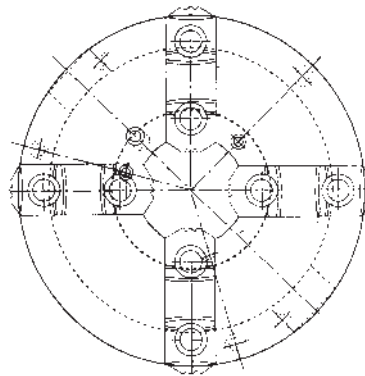

SPECIFICATIONS

Unit:mm

ORDER NO.	D	d1	d2	d3	L	L1	h	THREAD	GRIPPING RANGE		WEIGHT (kgs)	CODE NO.
									O.D. RANGE	I.D. RANGE		
VPS-6AK	165	130	145	45	109	65	5	3-M8	Ø4-Ø165	Ø55-Ø150	9.5	5002-055
VPS-8AK	200	165	180	65	122	75	5	3-M10	Ø4-Ø200	Ø65-Ø200	14.8	5002-057
VPS-10AK	250	206	226	80	136	80	5	3-M12	Ø6-Ø250	Ø90-Ø250	24.7	5002-058
VPS-12AK	315	260	285	100	156.5	90	6	3-M16	Ø10-Ø315	Ø100-Ø315	45.7	5002-059

CENTERING CHUCK



3-Jaw Scroll Chucks D1 Camlock Direct Mounting

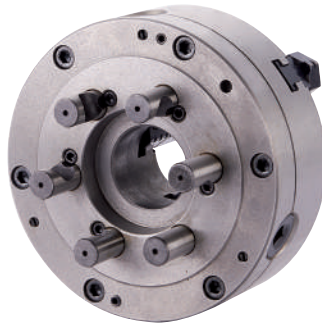

BACK SAMPLE

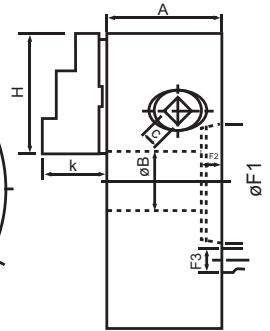
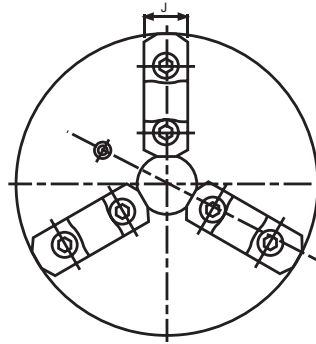

(ASA spindle nose D1-4, D1-5, D1-6, D1-8)

American standard camlock type with 2-piece reversible hard top jaws.

- Gripping accuracy of 0.03mm(0.002inch)T.I.R.
- Standard accessories A chuck wrench and hex. key One set of mounting bolts.(UNC-bolts)
- The body is made of MEEHANITE.

It is suitably used for high speed revolution and 3 times more durable than regular chucks.

SPECIFICATIONS

ORDER NO.	Spindle Size	Chuck Size	A	B	C	H	J	K	Mounting Dimensions				Gripping Range		Weight (kg)	Allowable Handle Torque (kgf.m)	Gripping Force (kgf)	I (kgf.M ²)	Max. Speed (r.p.m.)	CODE NO.
									F1	F2	F3	F4	O.D. Range	I.D. Range						
KD5-8 ⁹	D1-5	200	77	46	11	82	28	42	82.563	14.3	19	104.78	Ø8-Ø180	Ø62-Ø170	18	11.5	3600	0.07	3200	5002-061
KD6-8 ⁹	D1-6	200	77	58	11	82	28	42	106.375	16	22	133.35	Ø8-Ø180	Ø62-Ø170	17	17	3600	0.07	3200	5002-063



3-Jaw Powerful Camlock Type Self-Centering Chuck

NEW



SAMPLE

Ød4	
D1-5	82.563
D1-6	106.375
D1-8	106.375
D1-11	106.357

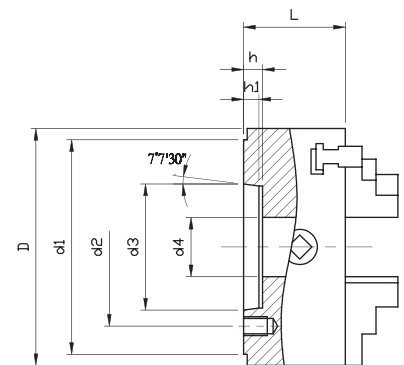
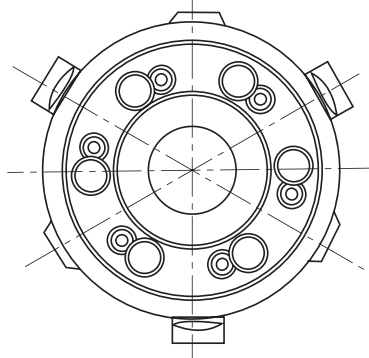

SPECIFICATIONS

ORDER NO.	D	MOUNTING TYPE	d1	d2	d3	d4	L	H1	h	THREAD	WEIGHT (kgs)	CODE NO.
VSKC-6A	160	D5	40	104.8	146	82.563	12	73	15	6-M12x1.0P	10	5002-111
VSKC-8A	200	D6	50	133.4	181	106.375	13	86	16	6-M16x1.5P	17	5002-112
VSKC-10A	250	D6	70	133.4	181	106.375	13	98	16	6-M16x1.5P	32	5002-113
VSKC-12A	315	D6	100	133.4	181	106.375	13	103.5	16	6-M16x1.5P	49	5002-114



DIN-Type 3-Jaw Self-Centering Chucks

**VERTEX®**

SIMILAR DIN6350

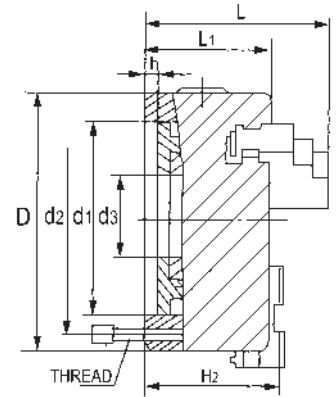
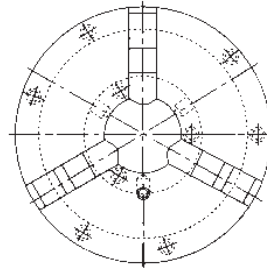

It have front mounting type as well.

SPECIFICATIONS

Unit:mm

ORDER NO.	D	d1	d2	d3	L	L1	h	THREAD	R.P.M. MAX SPEED	GRIPPING RANGE		WEIGHT (kgs)	CODE NO.
										O.D. RANGE	I.D. RANGE		
VSC-3D	80	56	67	16	66.5	50	4	3-M6	4000	Ø2-Ø70	Ø22-Ø63	1.9	5002-215
VSC-4D	100	70	83	22	74.5	55	3	3-M8	3500	Ø2-Ø90	Ø30-Ø80	3.3	5002-216
VSC-5D	125	95	108	30	84.5	58	4	3-M8	3000	Ø2.5-Ø125	Ø38-Ø110	5.2	5002-217
VSC-6D	160	125	140	45	94	65	5	6-M10	2500	Ø3-Ø160	Ø55-Ø145	9.1	5002-218
VSC-8D	200	160	176	65	109	75	5	6-M10	2500	Ø4-Ø200	Ø65-Ø200	16	5002-219
VSC-10D	250	200	224	80	120	80	5	6-M12	1600	Ø6-Ø250	Ø90-Ø250	27.5	5002-219A



4-Jaw Independent Chuck Plain Back

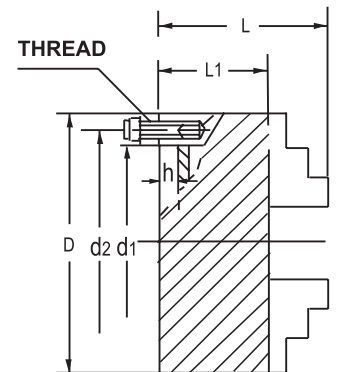
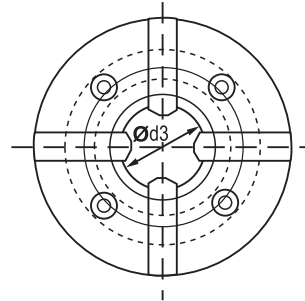

SPECIFICATIONS

Unit:mm

ORDER NO.	D-size	d1	d2	d3	L	L1	h	THREAD	R.P.M. MAX SPEED	GRIPPING RANGE		WEIGHT (kgs)	CODE NO.
										O.D. RANGE	I.D. RANGE		
VKC-4	100mm(4")	72	84	25	74	54	3.5	4-M8	2300	Ø6-Ø45	Ø40-Ø100	3.5	5002-220
VKC-5	125mm(5")	95	108	30	78	56	4.5		1900	Ø7-Ø57	Ø48-Ø125	5.1	5002-221
VKC-6	160mm(6")	65	95	45	93	75	5	4-M10	1500	Ø8-Ø80	Ø50-Ø160	8.3	5002-222
VKC-8	200mm(8")	80	112	56	107	80	6		1350	Ø10-Ø100	Ø63-Ø200	15.9	5002-223
VKC-10	250mm(10")	110	130	75	120	90	6	4-M12	1100	Ø15-Ø130	Ø80-Ø250	21.8	5002-224
VKC-12B	320mm(12")	140	165	95	134	90	8	4-M16	850	Ø20-Ø176	Ø100-Ø315	41	5002-226
VKC-14	350mm(14")	130	168	110		550			Ø20-Ø206	Ø100-Ø350	53.6	5002-227	
VKC-16	400mm(16")	160	185	125	143	95	8	4-M20	550	Ø25-Ø250	Ø118-Ø400	56	5002-228
VKC-20	500mm(21")	200	236	160	161	106	8		350	Ø35-Ø300	Ø125-Ø500	105	5002-229
VKC-25	630mm(25")	220	258	180	175	118	10	4-M20	280	Ø50-Ø400	Ø160-Ø630	162	5002-230
VKC-32	800mm(32")	250	300	210	202	132	12	8-M20	200	Ø70-Ø540	Ø200-Ø800	265	5002-231
VKC-40	1000mm(40")	320	370	260	241	150	15	8-M20	150	Ø100-680	Ø250-1000	536	5002-232
VKC-50	1250mm(50")	400	500	305	256	165	15	8-M20	150	Ø170-900	Ø250-1250	905	5002-233

SCROLL CHUCK

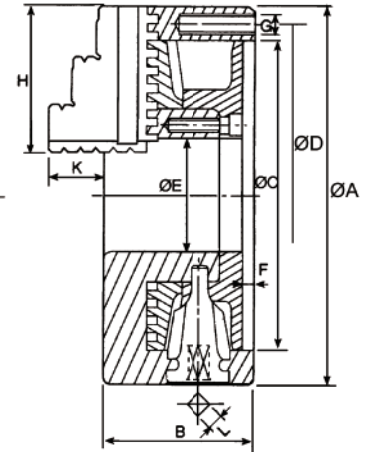
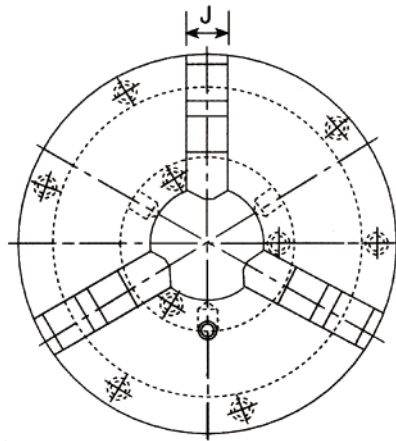

- Interchangeable utilization of internal and external hard jaws.
- VSC types feature economical and durable, suitable for mass production.

- Gripping accuracy of 0.03mm (0.012inch) T.I.R..
- The body is made of MEEHANITE. It is suitably used for high speed revolution and 3 times more durable than regular chucks.

SPECIFICATIONS

ORDER NO.	Dim											Allowable Handle Torque (kgf.m)	Gripping Force (kgf)	I (kgf.m)	Weight (kgs)	Max. Speed (r.p.m.)	Gripping Range		CODE NO.
	A	B	C	D	E	F	G	H	J	K	L						O.D. Range	I.D. Range	
VSC-3	85	46	60	73	16	4	3-M6	36	11	15	7	3.0	900	-	1.9	2500	Ø2-Ø70	Ø24-Ø64	5002-001
VSC-4	112	59	80	95	24	4.5	3-M8	42	14	17	8	4.5	1200	-	3.9	2500	Ø3-Ø90	Ø32-Ø84	5002-002
VSC-5	132	60	100	115	32	4.5	3-M8	50	16	20	8	6.5	1500	0.01	4.6	2500	Ø3-Ø110	Ø35-Ø100	5002-003
VSC-6	165	67	130	147	45	5	3-M10	63	19	23	10	9.0	3300	0.03	7.6	2000	Ø4-Ø160	Ø48-Ø150	5002-004
VSC-7	192	76.5	155	172	58	5	3-M10	77	21.5	28	11	11.0	3600	0.06	12	2000	Ø4-Ø180	Ø56-Ø170	5002-005
VSC-8	200	76.5	160	176	58	5	3-M10	77	21.5	28	11	11.0	3600	0.07	13.3	2000	Ø4-Ø180	Ø56-Ø170	5002-006
VSC-9	232	84	190	210	70	6	3-M12	87	24	34.5	12	15.0	3900	0.15	19.3	2000	Ø5-Ø220	Ø62-Ø210	5002-007
VSC-10	273	87	230	250	87	8.5	3-M12	98	28	39	12	19.5	4800	0.25	26.2	1800	Ø6-Ø260	Ø70-Ø250	5002-008
VSC-12	310	96	260	285	105	7	3-M12	110	30	45	14	21.0	5700	0.58	37.6	1800	Ø10-Ø300	Ø86-Ø290	5002-009
VSC-14	355	112	300	328	127	7	6-M12	132	35	50	15	23.0	4500	-	57.2	1500	Ø12-Ø350	Ø96-Ø230	5002-009A
VSC-16	405	122	345	375	160	8.5	3-M14	146	42	56	15	23.0	4500	1.75	80.7	1500	Ø14-Ø400	Ø100-Ø380	5002-010



3-Jaw Powerful Scroll Chuck



JIS STANDARD Accuracy Type

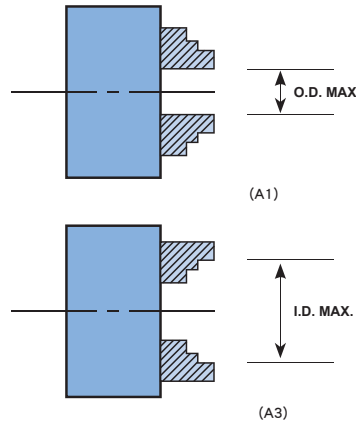
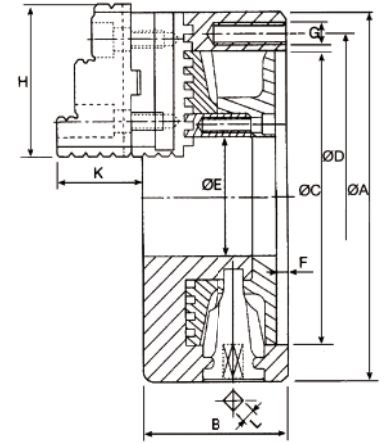
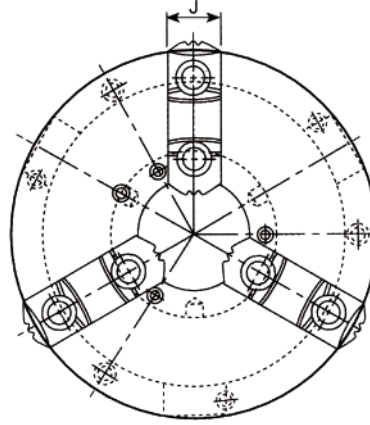

- VSK types chucks have wider utilization range; hard jaws suitable for heavy cutting; optional soft jaws suitable for light and precision cutting.
 - Hard jaws could be used as internal jaws and external jaws.
 - Gripping accuracy of 0.03mm(0.012inch) T.I.R.
 - The body is made of MEEHANITE.
- It is suitably used for high speed revolution and 3 times more durable than regular chucks.

SPECIFICATIONS

Unit:mm

ORDER NO.	Gripping Range	
	External Gripping ØA1	Internal Gripping ØA3
VSK-4	3-36	69-100
VSK-5	3-47	84-123
VSK-6	8-74	107-160
VSK-7	8-88	125-180
VSK-8	8-88	125-180
VSK-9	11-118	144-220
VSK-10	12-142	152-260
VSK-12	15-166	184-300
VSK-14	25-202	212-350
VSK-16	30-238	228-400
VSK-20	25-366	207-480

SPECIFICATIONS VSK reversible type

ORDER NO.	Dim											Allowable Handle Torque (kgf.m)	Gripping Force (kgf)	I (kgf.m)	Weight (kgs)	Max. Speed (r.p.m.)	Gripping Range		CODE NO.
	A	B	C	D	E	F	G	H	J	K	L						O.D. Range	I.D. Range	
VSK-4	112	58	80	95	24	4.5	3-M8	47	19	31.5	8	4.5	1200	-	3.45	2500	Ø3-Ø100	Ø35-Ø93	5002-028
VSK-5	132	60	100	115	32	4.5	3-M8	57	24	36	8	6.5	1500	-	5	2500	Ø3-Ø123	Ø43-Ø122	5002-029
VSK-6	165	67	130	147	45	5	3-M10	72	26	39	10	9.0	3300	0.03	9.5	2000	Ø8-Ø160	Ø55-Ø150	5002-030
VSK-7	192	76.5	155	172	58	5	3-M10	82	28	43	11	11.0	3600	0.06	12.8	2000	Ø8-Ø180	Ø62-Ø170	5002-031
VSK-8	200	76.5	160	176	58	5	3-M10	82	28	43	11	11.0	3600	0.07	14.7	2000	Ø8-Ø180	Ø62-Ø170	5002-032
VSK-9	232	84	190	210	70	5.5	3-M12	96	32	50	12	15.0	3900	0.16	20.4	2000	Ø11-Ø220	Ø70-Ø210	5002-033
VSK-10	273	87	230	250	87	5.5	3-M12	100	35	54.5	12	19.5	4800	0.26	26.7	1800	Ø12-Ø260	Ø80-Ø250	5002-034
VSK-12	310	96	260	285	105	7	3-M12	114	40	56	14	21.0	5700	0.58	39.3	1800	Ø15-Ø300	Ø90-Ø290	5002-035
VSK-14	355	112	300	328	127	7	6-M12	139	45	70.5	15	23.0	4500	-	60.7	1500	Ø25-Ø350	Ø110-Ø320	5002-035A
VSK-16	405	122	345	375	160	8	6-M14	150	50	75	15	23.0	4500	1.72	82.3	1500	Ø30-Ø400	Ø110-Ø380	5002-037
VSK-20	500	140	420	458	205	5.5	6M-14	140	55	84	19	-	-	-	145.5	1000	Ø25-Ø480	Ø125-Ø460	5002-038

SCROLL CHUCK

NEW

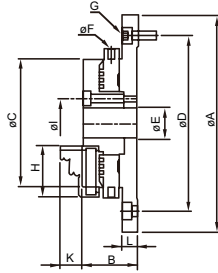
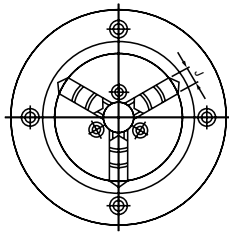

- Compact, Small And Light Weight
- No Wrench Required, Turn To Loose & Lock By Fixing Ring
- Steel Made Body
- Reversible Jaws
- VLBK-Series Is Latest Vertical Clamping Design For CNC, Milling Machine And Machining Center.

DIMENSIONS

ORDER NO.	A	B	C	D	E	F	G	H	I	J	K	L	Gripping Range		Weight (kgs)	CODE NO.
													O.D. Range	I.D. Range		
VLBK-2	118	28	63	100	16	4	4-M5X0.8P	27	26	8	13	8	ø0.8~ø63	ø23~ø58	1.2	5002-130
VLBK-3	143	37	85	116	20	4	4-M6X1.0P	35	32	11	15	10.5	ø1~ø81	ø31~ø70	2.9	5002-131
VLBK-4	168	39	110	140	26	5	4-M6X1.0P	42	40	14	19	10	ø1~ø100	ø36~ø90	4.6	5002-132
VLBK-5	202	45	130	168	32	6	4-M8X1.25P	50	49	16	21	11.5	ø1.5~ø116	ø43~ø106	6.2	5002-133
VLBK-6	248	52	160	208	50	8	4-M10X1.5P	65	70	19	26	15	ø1.5~ø160	ø52~ø148	11	5002-134

6-Jaw Awl Type Chucks

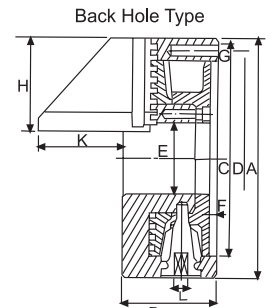
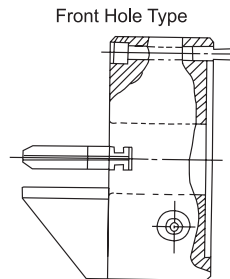
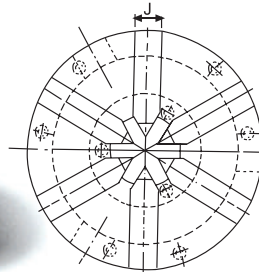

SPECIFICATIONS

ORDER NO.	A	B	C	D	E	F	G	H	J	K	L	Gross Weight (kgs)	Max. Speed (r.p.m.)	Max. Gripping Diameter	CODE NO.
														O.D. Clamping	
VAS-4	112	58	80	95	32	4.5	3-M8	45	14	46	8	4.2	1200	ø2-32	5005-011
VAS-6	167	65	130	147	60	5	3-M10	66	19	43	10	9.2	1200	ø3-60	5005-012

Unit:mm

Quality standard For Lathe Chuck

Accuracy

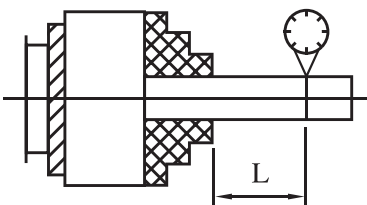

ORDER NO.	VSC-3,4,5,6,7,8,9,10,12,14,16 VSK-4,5,6,7,8,9,10,12,14,16 VMJ-6,8,10,12,150,200,250,300 VNBK-6,8,10,12	VSC-3A,4A,5A,6A,7A,8A,9A,10A VSC-12A,16A,20A,25A VSK-6A,8A,10A,12A,13A,16A VPS-6A,8A,10A,12A,6AK,8AK VPS-10AK,12AK VSKC-6A,8A,10A,12A VSC-3D,4D,5D,6D,8D,10D VKC-4,5,6,8,10,12B,14,16,20,25 VKC-32,40,50
TEST ITEM	L	L
RADIAL RUNOUT	0.05 / 50 mm	0.10 / 50 mm

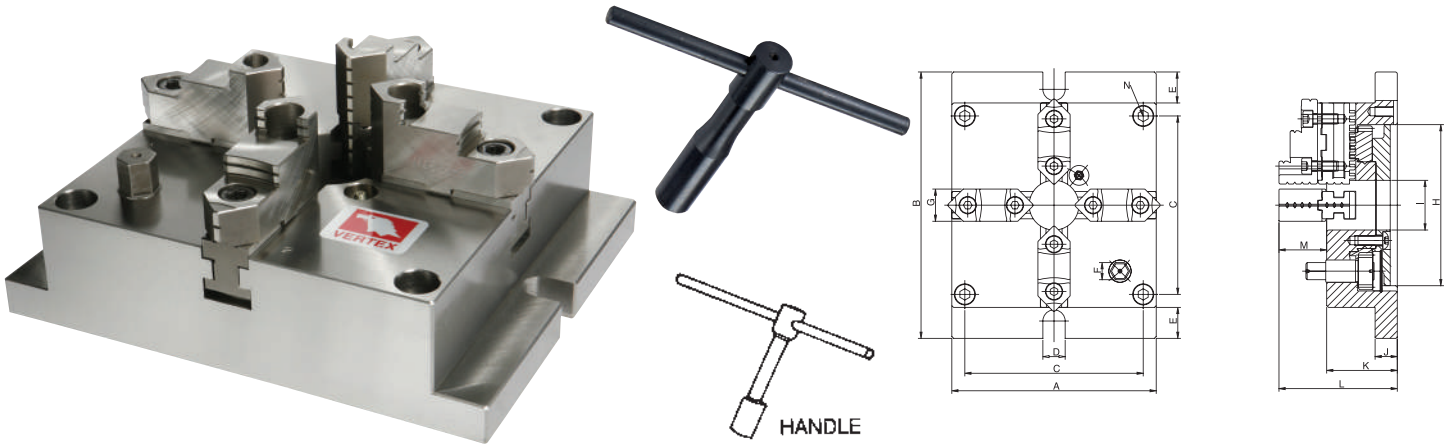

- Works are gripped firmly by the formed jaws. ensuring high precision. (Deviation: within 0.03mm)* Use forming rings (jaw locks) to form the soft-jaws.
- Large workpieces can be held tight with the low profile vise body.
- Able to grip square works by using this chuck as a two-way jaw unit * The fixed jaw(optional)is necessary. Longitudinal works can also begripped by using the bore of this chuck.
- A dust cover is provided and this keeps the shavings from entering the machine.
- The handle is set on the face and does not interfere with the table. A number of chucks can be used together.

SPECIFICATIONS

Unit:mm

ORDER NO.	A	B	C	D	E	G	H	I	J	K	L	M	N	MAX. GRIPPING DIAMETER		Gripping Force (kgf)	WEIGHT (kgs)	CODE NO.
														CLAMPING DIA	PROPING DIA			
VMJ-6	165	215	144	18	25	26	130	40	18	57	96	39	4-M10	Ø4-Ø128	Ø55-Ø128	900	13.5	5002-240
VMJ-8	200	250	174	18	25	28	160	55	20	65	108	43	4-M12	Ø5-Ø162	Ø62-Ø162	1620	21.5	5002-241
VMJ-10	250	310	218	18	30	32	200	70	22	72	122	50	4-M14	Ø6-Ø200	Ø72-Ø200	1800	36.1	5002-242
VMJ-12	310	380	274	22	35	40	260	100	25	85	141	56	4-M16	Ø10-Ø265	Ø90-Ø265	2250	62.8	5002-243

Super Thin Chucks

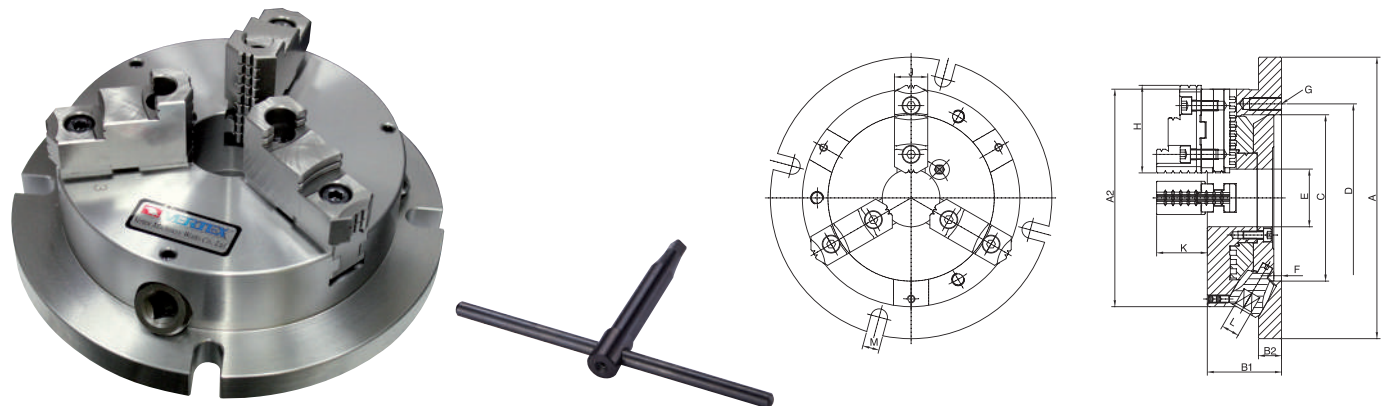

- The angle between "HANDLE" AND "BASE OF CHUCK" is 30° degree, There Fore, it is much more convenient for "HANDLE" rotation.
- This "POWER SUPER THIN" design of chuck may increase the "allowable length" of machining operation.
- The flanged type design make it easily for loading and unloading operation. Four locate position 90°.
- "POWERFUL TYPE" design.

SPECIFICATIONS

Unit:mm

ORDER NO.	Dim														Gripping Force (kgf)	Weight (kgs)	Gripping Range		CODE NO.
	A1	A2	B1	B2	C	D	E	F	G	H	J	K	L	M			O.D. Range	I.D. Range	
VNBK-6	220	170	58	18	130	147	45	6	3-M10	68	26	40	10	13	1800	12.4	Ø8-160	Ø48-150	5002-070
VNBK-8	270	210	65	20	155	172	60	6	3-M10	82	28	43	11	13	2250	20.2	Ø11-200	Ø62-190	5002-071
VNBK-10	315	255	73	20	190	210	80	6	3-M12	93	32	52	12	16	3150	30.5	Ø12-250	Ø72-240	5002-072
VNBK-12	370	305	80	22	250	285	105	5	3-M12	118	40	59	14	18	3670	46.8	Ø15-300	Ø86-290	5002-073

NEW



● VSK REVERSIBLE TYPE

VMJ-150, 200, 250, 300



NEW TYPE 3 JAW CHUCK CHANGEABLE

NEW

VMJ-B150, B200, B250, B300



● VSC REVERSIBLE TYPE

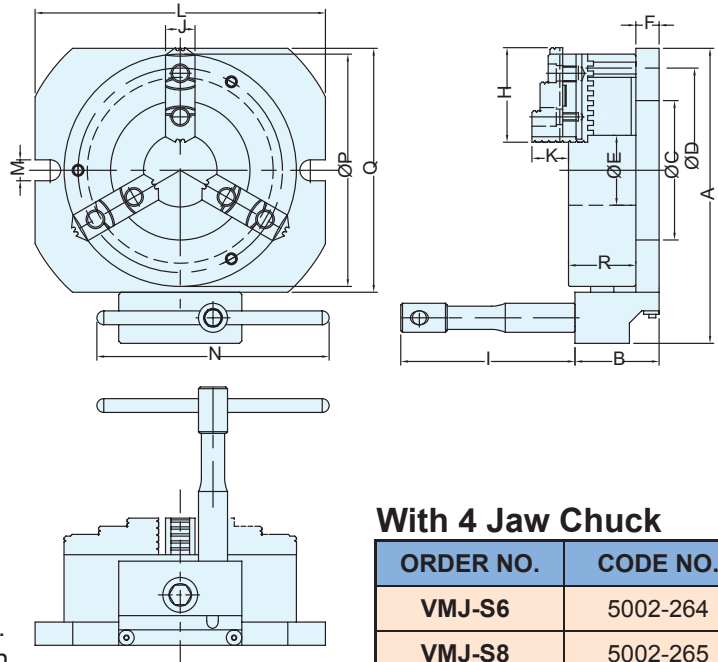

- Convert 3/4 Jaws chuck into clamping chuck.
- Vertical cutting / locking.
- Large workpieces can be held tight with the low profile vise body.
- 3 Jaws can for round workpiece.
- 4 Jaws can for square workpiece & round workpiece.
- The handle is set on the face and does not interfere with the table. A number of chucks can be used together.
- Suit for MC center, Milling & Boring machine.
- Easy to exchange 3/4 Jaws chuck.

With 4 Jaw Chuck

ORDER NO.	CODE NO.
VMJ-S6	5002-264
VMJ-S8	5002-265
VMJ-S10	5002-266
VMJ-S12	5002-267

SPECIFICATIONS VSK TYPE

Unit:mm

ORDER NO.	A	B	C	D	E	F	H	I	J	K	L	M	N	P	Q	R	Gnpping Range		Weight (kgs)	CODE NO.
																	O.D Range	I.D Range		
VMJ-150	219	83	90	147	45	20	72	150	26	39	215	18	200	165	175	67	Ø8-Ø160	Ø55-Ø150	17.7	5002-260
VMJ-200	254	83	120	176	58	20	82	150	28	43	250	18	200	200	200	76.5	Ø8-Ø180	Ø62-Ø170	24.4	5002-261
VMJ-250	327	83	190	250	87	24	100	150	35	50	324	18	200	273	283	87	Ø12-Ø260	Ø80-Ø250	48.7	5002-262
VMJ-300	364	83	220	285	105	24	114	150	40	56	360	18	200	310	320	96	Ø15-Ø300	Ø90-Ø290	63.7	5002-263

SPECIFICATIONS VSC TYPE

Unit:mm

ORDER NO.	A	B	C	D	E	F	H	I	J	K	L	M	N	P	Q	R	Gnpping Range		Weight (kgs)	CODE NO.
																	O.D Range	I.D Range		
VMJ-B150	219	83	90	147	45	20	72	150	19	39	215	18	200	165	175	67	Ø3-Ø160	Ø48-Ø150	17.7	5002-275
VMJ-B200	254	83	120	176	58	20	82	150	21.5	43	250	18	200	200	200	76.5	Ø4-Ø180	Ø56-Ø170	24.9	5002-276
VMJ-B250	327	83	190	250	87	24	100	150	28	50	324	18	200	273	283	87	Ø6-Ø260	Ø70-Ø250	50	5002-277
VMJ-B300	364	83	220	285	105	24	114	150	30	56	360	18	200	310	320	96	Ø10-Ø300	Ø86-Ø290	66.5	5002-278



Soft Jaw For SK-Type Chuck



1. Soft jaw for SK-type chuck. 2. Manufactured in specification
Can for Japanese brand 3 jaw chuck KITAGAWA, HOWA, VICTOR



3 PCS/SET

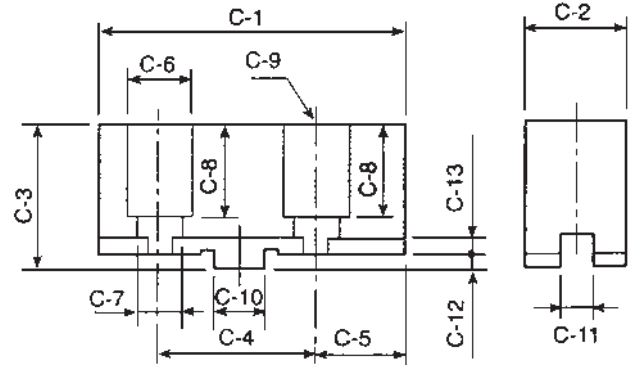

Unit:mm

Dim ORDER NO.	C-1	C-2	C-3	C-4	C-5	C-6	C-7	C-8	C-9	C-10	C-11	C-12	C-13	Weight (kgs)	CODE NO.
VSJ-4	52	19	30	24	14	11	7	21	M6	9.53	7.94	2.5	3	0.45	5002-298
VSJ-5	62	24	35	32	15	14	9	24	M8	12.68	7.94	3	3.5	0.9	5002-299
VSJ-6	75	26	38	38.1	18	14	8.5	27	M8	12.68	7.94	3	3.5	1.3	5002-300
VSJ-7	95	31	48	44.45	25	17	11	35	M10	12.68	7.94	3	3.5	3.4	5002-301
VSJ-8	95	31	48	44.45	25	17	11	35	M10	12.68	7.94	3	3.5	2.7	5002-302
VSJ-9	110	37	48	53.98	28	19	13	36	M12	19.03	12.7	3	3.5	3.7	5002-303
VSJ-10	110	37	48	53.98	28	19	13	36	M12	19.03	12.7	3	3.5	3.7	5002-304
VSJ-12	125	40	54	63.5	32	19	13	40.5	M12	19.03	12.7	3	3.5	5.3	5002-305
VSJ-16	160	50	70	76.2	42	25	17	48	M16	19.03	12.7	6	5.5	10.6	5002-306

THE SPECIAL OF HEIGHT (C-3) FOR VSJ-TYPE IS AVAILABLE

ORDER NO.	MODEL	HEIGHT	CODE NO.
VSJ-6-5	VSJ-6	50H	5002-3005
VSJ-6-6	VSJ-6	60H	5002-3006
VSJ-6-7	VSJ-6	70H	5002-3007
VSJ-6-8	VSJ-6	80H	5002-3008
VSJ-6-9	VSJ-6	90H	5002-3009
VSJ-8-5	VSJ-7 VSJ-8	50H	5002-3025
VSJ-8-6	VSJ-7 VSJ-8	60H	5002-3026
VSJ-8-7	VSJ-7 VSJ-8	70H	5002-3027
VSJ-8-8	VSJ-7 VSJ-8	80H	5002-3028
VSJ-8-9	VSJ-7 VSJ-8	90H	5002-3029
VSJ-9-5	VSJ-9	50H	5002-3035
VSJ-9-6	VSJ-9	60H	5002-3036
VSJ-9-7	VSJ-9	70H	5002-3037
VSJ-9-8	VSJ-9	80H	5002-3038
VSJ-9-9	VSJ-9	90H	5002-3039
VSJ-9-10	VSJ-9	100H	5002-30310
VSJ-9-12	VSJ-9	120H	5002-30312

ORDER NO.	MODEL	HEIGHT	CODE NO.
VSJ-10-5	VSJ-10	50H	5002-3045
VSJ-10-6	VSJ-10	60H	5002-3046
VSJ-10-7	VSJ-10	70H	5002-3047
VSJ-10-8	VSJ-10	80H	5002-3048
VSJ-10-9	VSJ-10	90H	5002-3049
VSJ-10-10	VSJ-10	100H	5002-30410
VSJ-10-12	VSJ-10	120H	5002-30412
VSJ-10-13	VSJ-10	130H	5002-30413
VSJ-12-6	VSJ-12	60H	5002-3056
VSJ-12-7	VSJ-12	70H	5002-3057
VSJ-12-8	VSJ-12	80H	5002-3058
VSJ-12-9	VSJ-12	90H	5002-3059
VSJ-12-10	VSJ-12	100H	5002-30510
VSJ-12-12	VSJ-12	120H	5002-30512
VSJ-12-13	VSJ-12	130H	5002-30513
VSJ-12-15	VSJ-12	150H	5002-30515
VSJ-16-10	VSJ-16	100H	5002-30610
VSJ-16-12	VSJ-16	120H	5002-30612

POWER CHUCK



Soft Jaw For Hydraulic Power Chucks



For Japanese brand JIS & KITAGAWA

STANDARD
3 PCS/SET

ALUMINIUM

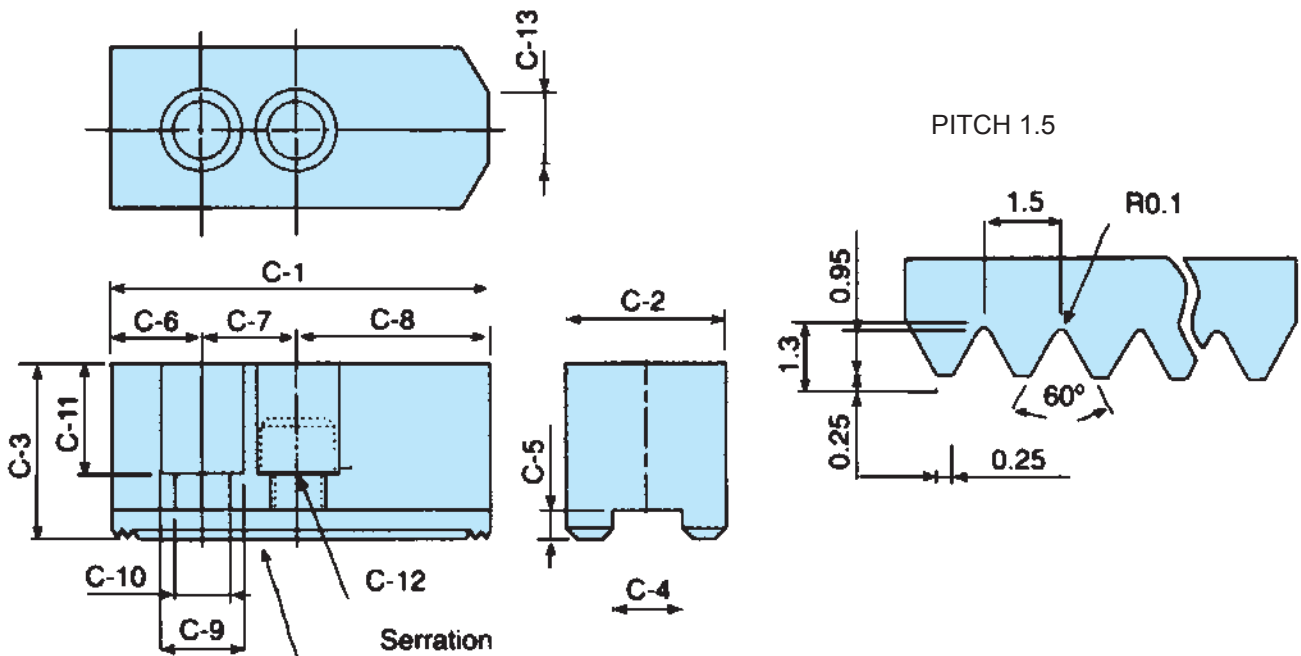
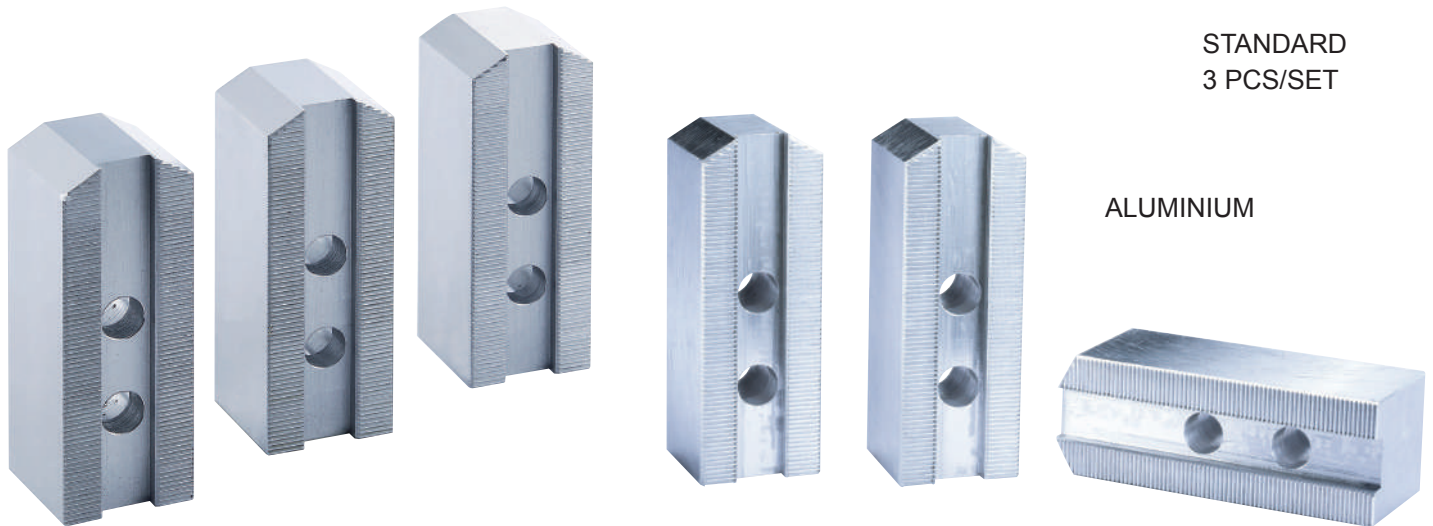

MATERIAL: STEEL

Unit:mm

Dim	C-1	C-2	C-3	C-4	C-5	C-6	C-7	C-8	C-9	C-10	C-11	C-12	C-13	Weight (kgs)	CODE NO.
VHC-05	62	25	30	10	5	9	14	39	13.5	9	21	M8	5	0.9	5002-330
VHC-06	73	31	36	12	5	15	20	38	17	11	23	M10	14	1.6	5002-331
VHC-08	95	35	37	14	5	24	25	46	19	13	22	M12	16	2.4	5002-332
VHC-10	110	40	42	16	5	30	30	50	19	13	27	M12	18	3.7	5002-333
VHC-12	130	50	50	21	5	39	30	61	25	17	30	M16	23	6.4	5002-334
VHC-15	165	62	62	22	8	37	43	85	32	21	38	M20	-	12.7	5002-335
VHC-12-1	130	50	50	18	5	39	30	61	23	15	30	M14	23	6.25	5002-336
VHC-15-1	165	62	62	25.5	5	37	43	85	32	21	38	M20	-	13	5002-337
VHC-24	180	64	70	25	9	40	60	80	32	21	45	M20	-	17	5002-338

MATERIAL : ALUMINIUM

Unit:mm

Dim	C-1	C-2	C-3	C-4	C-5	C-6	C-7	C-8	C-9	C-10	C-11	C-12	C-13	Weight (kgs)	CODE NO.
VHC-8A	95	35	37	14	5	24	25	46	19	13	22	M12	16	0.84	5002-250A
VHC-10A	110	40	42	16	5	30	30	50	19	13	27	M12	18	1.31	5002-251A



THE SPECIAL OF HEIGHT (C-3) FOR VHC-TYPE IS AVAILABLE

ORDER NO.	MODEL	HEIGHT	CODE NO.
VHC-05-5	VHC-05	50H	5002-3305
VHC-05-6	VHC-05	60H	5002-3306
VHC-05-7	VHC-05	70H	5002-3307
VHC-05-8	VHC-05	80H	5002-3308
VHC-06-5	VHC-06	50H	5002-3315
VHC-06-6	VHC-06	60H	5002-3316
VHC-06-7	VHC-06	70H	5002-3317
VHC-06-8	VHC-06	80H	5002-3318
VHC-06-9	VHC-06	90H	5002-3319
VHC-06-10	VHC-06	100H	5002-3320
VHC-06-11	VHC-06	110H	5002-3321
VHC-06-12	VHC-06	120H	5002-3322
VHC-06-13	VHC-06	130H	5002-3323
VHC-06-15	VHC-06	150H	5002-3324
VHC-08-5	VHC-08	50H	5002-3325
VHC-08-6	VHC-08	60H	5002-3326
VHC-08-7	VHC-08	70H	5002-3327
VHC-08-8	VHC-08	80H	5002-3328
VHC-08-9	VHC-08	90H	5002-3329
VHC-08-10	VHC-08	100H	5002-3330
VHC-08-11	VHC-08	110H	5002-3331
VHC-08-12	VHC-08	120H	5002-3332
VHC-08-13	VHC-08	130H	5002-3333
VHC-08-14	VHC-08	140H	5002-3334
VHC-08-15	VHC-08	150H	5002-3334A
VHC-08-16	VHC-08	160H	5002-3334B
VHC-08-18	VHC-08	180H	5002-3334C
VHC-08-20	VHC-08	200H	5002-3334D
VHC-10-5	VHC-10	50H	5002-3335
VHC-10-6	VHC-10	60H	5002-3336
VHC-10-7	VHC-10	70H	5002-3337
VHC-10-8	VHC-10	80H	5002-3338
VHC-10-9	VHC-10	90H	5002-3339
VHC-10-10	VHC-10	100H	5002-33310
VHC-10-11	VHC-10	110H	5002-33311

ORDER NO.	MODEL	HEIGHT	CODE NO.
VHC-10-12	VHC-10	120H	5002-33312
VHC-10-13	VHC-10	130H	5002-33313
VHC-10-14	VHC-10	140H	5002-33314
VHC-10-15	VHC-10	150H	5002-33315
VHC-10-16	VHC-10	160H	5002-33316
VHC-10-18	VHC-10	180H	5002-33318
VHC-10-20	VHC-10	200H	5002-33320
VHC-10-22	VHC-10	220H	5002-33322
VHC-12-6A	VHC-12 18SLOT	60H	5002-3366
VHC-12-7A	VHC-12 18SLOT	70H	5002-3367
VHC-12-8A	VHC-12 18SLOT	80H	5002-3368
VHC-12-9A	VHC-12 18SLOT	90H	5002-3369
VHC-12-10A	VHC-12 18SLOT	100H	5002-33610
VHC-12-6	VHC-12 21SLOT	60H	5002-3346
VHC-12-8	VHC-12 21SLOT	80H	5002-3348
VHC-12-10	VHC-12 21SLOT	100H	5002-33410
VHC-12-11	VHC-12 21SLOT	110H	5002-33411
VHC-12-12	VHC-12 21SLOT	120H	5002-33412
VHC-12-13	VHC-12 21SLOT	130H	5002-33413
VHC-12-14	VHC-12 21SLOT	140H	5002-33414
VHC-12-15	VHC-12 21SLOT	150H	5002-33415
VHC-12-16	VHC-12 21SLOT	160H	5002-33416
VHC-12-17	VHC-12 21SLOT	170H	5002-33417
VHC-12-18	VHC-12 21SLOT	180H	5002-33418
VHC-12-19	VHC-12 21SLOT	190H	5002-33419
VHC-12-20	VHC-12 21SLOT	200H	5002-33420
VHC-15-7	VHC-15	70H	5002-3357
VHC-15-8	VHC-15	80H	5002-3358
VHC-15-9	VHC-15	90H	5002-3359
VHC-15-10	VHC-15	100H	5002-33510
VHC-15-12	VHC-15	120H	5002-33512
VHC-15-15	VHC-15	150H	5002-33515
VHC-15-18	VHC-15	180H	5002-33518
VHC-15-20	VHC-15	200H	5002-33520

Soft Jaw Forming Ring

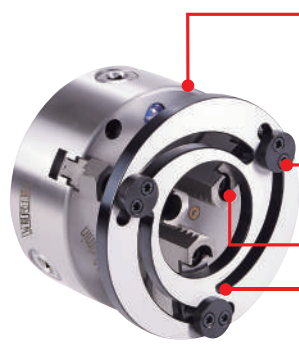

The size can be adjusted against the helical slot.

Bias pin can be rotated 180 degree for different size to extend a clamping range.

Don't need to drill new hole. The hole on the soft jaws can be used directly for bias pin.

The material is hardened and ground, can last for a long time.

FAETURES

CHUCK NOT INCLUDED

- Forming ring is available for 5", 6", 8", 10" & 12" power chuck.
- The clamping force is increasing. the roundness and vibration caused by eccentricity can be improved. The cutting accuracy is much better because of no taper hole(as fig.3) and less vibration.
- Both Clamping(as fig.1) and extension (as fig. 2) are available. Meanwhile ,the size adjusting is at will, the operation is easy and enduring.
- More improvement for used chuck to have better accuracy & strong clamping force .
- For CNC Lathe.

INSTRUCTION

Because the forming ring is used for cutting soft jaws by clamping and with extending. through-hole could increase the accuracy of clamping work piece. (please refer to fig.1.2&3)

As fig.4 the soft jaw is created without forming ring. Cause bad accuracy. The clamping force is not stable & vibration will occur.

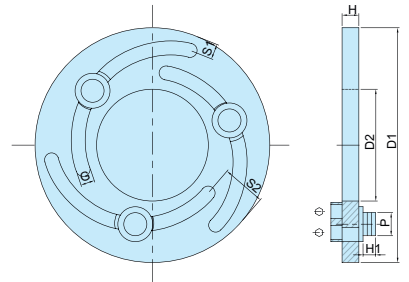
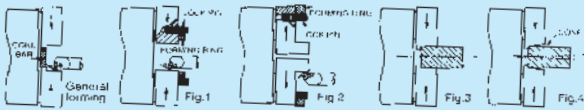

ORDER NO.	SUIT TO SK-CHUCK SIZE	H	D1	D2	S1	S2	G	H1	O	KGS	CODE NO.
VFR-05	5"	12	140	60	12	28	10	9	13.5	1	5002-360
VFR-06	6"	12	168	80	12	32	10	9	16.5	1.5	5002-361
VFR-08	8"	12	218	115	17	36	10	9	18.5	2.4	5002-362
VFR-10	10"	12	258	150	15	40	10	9	18.5	3	5002-363
VFR-12	12"	15	316	188	21	50	10	9	21.5	5	5002-364
VFR-15	15"	20	380	230	23	52	12	16	31	10.1	5002-365

Round Disc Soft Jaw

MATERIAL : STEEL S45C

NEW

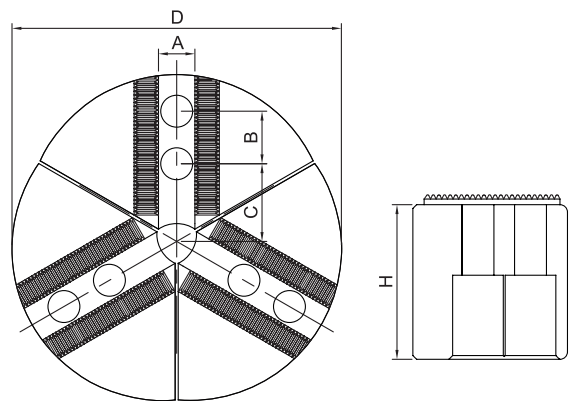
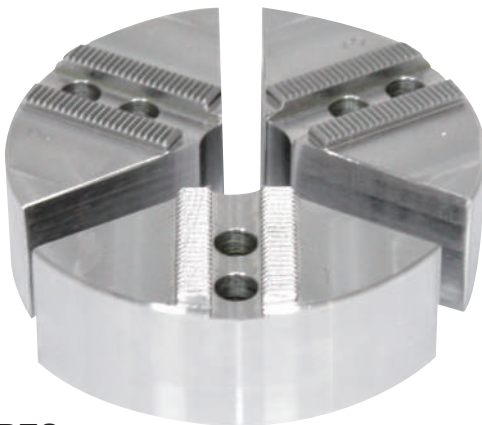

FAETURES

- This type of soft jaw can cover the outerdie of workpiece to decrease deformation and increase the accuracy.
- For example : VFRD-8 can hold parts with outer dia. of 200 mm.
- Pie Jaw are suitable for extra bigger outer dia. (thin wall)
- To suit kitagawa and other famous chucks.
- Pie shpspe soft jaw

Unit:mm

ORDER NO.	D	A	B	C	H	THREAD	THRU HOLE	SERRATION PITCH	WEIGHT (kg)	CODE NO.
VFRD-6	169	12	20	49.5	36	M10	25	1.5x60°	6.12	5002-381
VFRD-8	200	14	25	51	40	M12			9.64	5002-382
VFRD-9	200	14	25	51	50	M12			13.2	5002-383
VFRD-10	250	16	30	65	50	M12			18.1	5002-384
VFRD-12	300	21	30	81	50	M16			25.8	5002-385

NEW

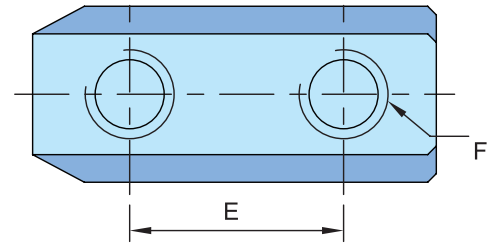
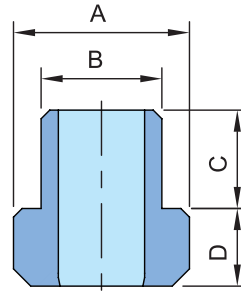

● For connect power chuck and soft jaws, suit for JAPANESE & TAIWANNES brands chuck.

For Kitagawa B-200 Series & Taiwannes Power Chuck

ORDER NO.	CHUCK SIZE	A	B	C	D	E	F	WEIGHT (kg)	CODE NO.
B-205T	5"	14	10	9.5	5	14	M8	0.1	5002-390
B-206T	6"	17.5	12	11	7.5	20	M10	0.1	5002-391
B-208T	8"	20.5	14	12	8.5	25	M12	0.2	5002-392
B-210T	10"	22.5	16	13	8.5	30	M12	0.3	5002-393
B-212T	12"	28	21	16.5	11.5	30	M16	0.6	5002-394

Hard Jaws For Hydraulic Power Chucks

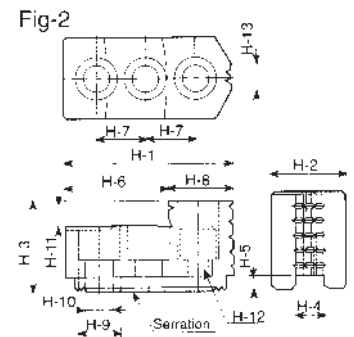
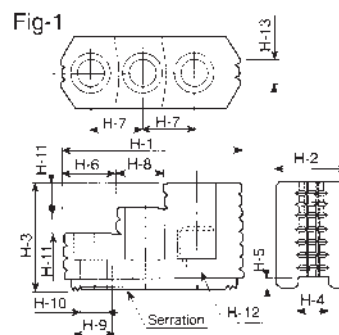

DIMENSIONS

ORDER NO.	Dim														Unit:mm				
		H-1	H-2	H-3	H-4	H-5	H-6	H-7	H-8	H-9	H-10	H-11	H-12	H-13	Serration Pitch	Matching Chuck	3-Jaw Weight (kgs)	CODE NO.	
HJ05		53	23	27.5	10	4	30.5	14	22.5	13.5	8.5	10	M8	6	1.5x60°	Fig-2	N-205	0.4	5002-401
HJ06		67.5	31	35	12	5	39.5	20	27.5	17	11	12	M10	16	1.5x60°	Fig-2	N-206.V-206	1.0	5002-402
HJ08		86	35	51	14	5	31	25	18	19	13	12	M12	12	1.5x60°	Fig-1	N-208.V-208	1.9	5002-403
HJ10		99.5	40	54	16	5	43	30	17	19	13	13	M12	15	1.5x60°	Fig-1	N-210.V-210	2.9	5002-404
HJ12		103	50	52	21	4	62.5	30	40.5	25	17	17	M16	30	1.5x60°	Fig-2	N-212	2.65	5002-405
HJ12-1		103	50	52	18	5	62.5	30	40.5	22	15	17	M14	30	1.5x60°	Fig-2	V-212	2.7	5002-406
HJ15		149	62	86	22	8	63	43	34	32	21	20	M20	40	1.5x60°	Fig-1	N-215	9.6	5002-407
HJ15-1		149	62	86	25.5	5	63	43	34	32	21	20	M20	40	1.5x60°	Fig-1	V-215	9.5	5002-408

HYDRAULIC CHUCK



3-Jaw Wedge Type Through-hole Power Chuck (Without Adaptor)

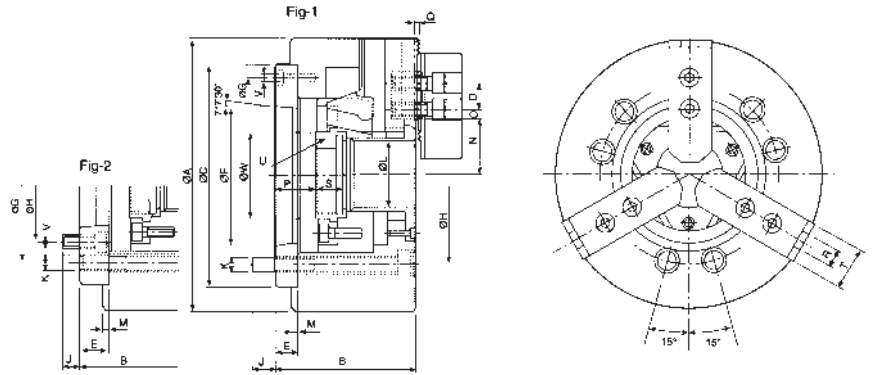

- More large bore:
Having the largest bore in wedge type power operated chucks.
- 20% large bore:
Approximately 20% higher speed, higher gripping force and larger bore compared with usual chucks.
- Model N-200A chucks are assembled with adaptor for ASA B5.9 type A spindles.
- Model N-200A chucks are manufactured from high grade alloy steel, All sliding surfaces are hardened and ground for accurate actual running and long service repeatability.

SPECIFICATIONS

Unit:mm

Dim	ORDER NO.	N-205A4	N-206A5	N-208A5	N-208A6	N-210A6	N-210A8	N-212A8	N-215A8	N-215A11
Through-Hole (mm)		ø33	ø45	ø52	ø52	ø75	ø75	ø91	ø117.5	ø117.5
Plunger Stroke (mm)		10	12	16	16	19	19	23	23	23
Jaw Stroke (mm)		5.4	5.5	7.4	7.4	8.8	8.8	10.6	10.6	10.6
Max. Draw Bar Pull Force (kgf)		1700	2200	3400	3400	4300	4300	5500	7240	7240
Max. Gripping Force (kgf)		3600	5700	8800	8800	11000	11000	14300	18355	18355
Gripping Range		Ø10~135	Ø13~169	Ø13~210	Ø13~210	Ø30~254	Ø30~254	Ø35~304	Ø35~381	Ø35~381
Max. Operating Pressure (kgf/cm ²)		29.6	28.5	26.5	26.5	27.5	27.5	27.5	23.5	23.5
Max. Speed (r.p.m.)		7000	6000	4900	4900	4200	4200	3300	2500	2500
Weight (kgs)		6.9	14.2	25.8	24.05	40.9	37.4	63.2	134	127
Matching Cylinder		M1036	M1246	M1552	M1552	M1875	M1875	M2091	M2511	M2511
Matching Soft Jaw		VHC05	VHC06	VHC08	VHC08	VHC10	VHC10	VHC12	VHC15	VHC15
Matching Hard Jaw		HJ05	HJ06	HJ08	HJ08	HJ10	HJ10	HJ12	HJ15	HJ15
CODE NO.		5002-080	5002-081	5002-082	5002-083	5002-084	5002-085	5002-086	5002-087	5002-088

DIMENSIONS

Unit:mm

Dim	ORDER NO.	N-205A4	N-206A5	N-208A5	N-208A6	N-210A6	N-210A8	N-212A8	N-215A8	N-215A11
A		135	169	210	210	254	254	304	381	381
B		71	91	109	103	120	113	122	160	149
G		96	116	133.35	150	171.45	190	190	235	260
D		14	20	25	25	30	30	30	43	43
E		15	15	23	17	25	18	18	33	22
F		65.513	82.563	82.563	106.375	106.375	139.719	139.719	139.719	196.869
C		110	140	170	170	220	220	220	300	300
H		82.55	104.78	104.78	133.35	133.35	171.45	171.45	171.45	235
J		15.5	16	13	18	18	24	25	24	28
K		3xM10	6xM10	6xM12	6xM12	6xM16	6xM16	6xM16	6xM20	6xM20
L		33	45	52	52	75	75	91	117.5	117.5
M		4	5	5	5	5	5	6	6	6
N max.		26.5	32	38.7	38.7	51	51	61.3	82	82
N min.		23.8	29.25	35	35	46.6	46.6	56	76.7	76.7
O max.		19.75	22.75	29.75	29.75	33.75	33.75	45.75	46.75	46.75
O min.		7.75	9.25	14.75	14.75	14.25	14.25	15.75	13.75	13.75
P max.		16	26	37.5	31.5	33.5	26.5	26	40	29
P min.		6	14	21.5	15.5	14.5	7.5	3	17	6
Q		2	2	2	2	2	2	2	5	5
R		10	12	14	14	16	16	21	24	24
S		20	19	20.5	20.5	25	25	28	43	43
T		23	32	37	37	42	42	52	62	62
U max.		M40x1.5	M55x2.0	M60x2.0	M60x2.0	M85x2.0	M85x2.0	M100x2.0	M130x2.0	M130x2.0
V		3xM6	3xM6	6xM10	3xM6	6xM12	6xM8	6xM8	6xM16	3xM10
W		45	60	66	66	94	94	108	139	139
REFER FIG.		Fig-1	Fig-1	Fig-2	Fig-1	Fig-2	Fig-1	Fig-1	Fig-2	Fig-1



2-Jaw Wedge Type Through-hole Power Chuck (Without Adaptor)

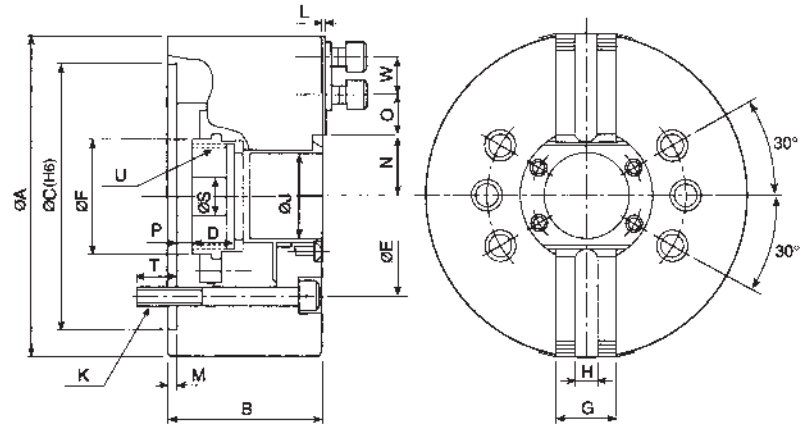

- All sliding surfaces are hardened and ground for accurate actual running and long service repeatability. Lubrication nipple in each base jaw.
- Base jaw: 1.5mmx60° serration.
- Mounting: Adaptor mounting to fit with DIN,ISO,BS,ASA B5.9 type A spindles.

SPECIFICATIONS

Unit:mm

Dim	ORDER NO.	NT205	NT206	NT208	NT210	NT212	NT215
Through-Hole (mm)		Ø33	Ø45	Ø52	Ø75	Ø91	Ø117.5
Plunger Stroke (mm)		10	12	16	19	23	23
Jaw Stroke (mm)		5.4	5.5	7.4	8.8	10.6	10.6
Max. Draw Bar Pull Force (kgf)		1189	1479	2294	2906	3739	4793
Max. Gripping Force (kgf)		2447	3875	5710	7546	9789	12236
Max. Speed (r.p.m.)		7000	6000	4800	4200	3300	2500
Weight (kgs)		5.9	13	22.1	33.2	61.9	115
Matching Cylinder		M1036	M1246	M1552	M1875	M2091	M2511
Max. Operating Pressure (kgf/cm ²)		19.5	18.9	17.3	18.4	18.4	15.3
Matching Soft Jaw		VHC05	VHC06	VHC08	VHC10	VHC12	VHC15
Matching Hard Jaw		HJ05	HJ06	HJ08	HJ10	HJ12	HJ15
CODE NO.		5002-250	5002-251	5002-252	5002-253	5002-254	5002-255

DIMENSIONS

Unit:mm

Dim	ORDER NO.	NT205	NT206	NT208	NT210	NT212	NT215
A		135	169	210	254	304	381
B		60	81	91	100	110	133
C (H6)		110	140	170	220	220	300
D		20	19	20.5	25	28	43
E		82.55	104.78	133.35	171.45	171.45	235
M		4	5	5	5	6	6
G		23	32	37	42	52	62
H		10	12	14	16	21	24
J		33	45	52	75	91	117.5
K		3-M10	6-M10	6-M12	6-M16	6-M16	6-M20
L		2	2	2	2	2	5
F		45	60	66	94	108	139
N max.		26.5	32	38.7	51	61.3	82
N min.		23.8	29.25	35	46.6	56	76.7
O max.		19.75	22.75	29.75	33.75	45.75	46.75
O min.		7.75	9.25	14.75	14.25	15.75	13.75
P max.		1	11	14.5	8.5	8	7
P min.		-9	-1	-1.5	-10.5	-15	-16
S		12	20	30	45	50	60
T		15.5	16	20	22	23	30
U max.		M40x1.5	M55x2	M60x2	M85x2	M100x2	M130x2
W		14	20	25	30	30	43

POWER CHUCK



3-Jaw Wedge Type Non Through-hole Power Chuck (Without Adaptor)

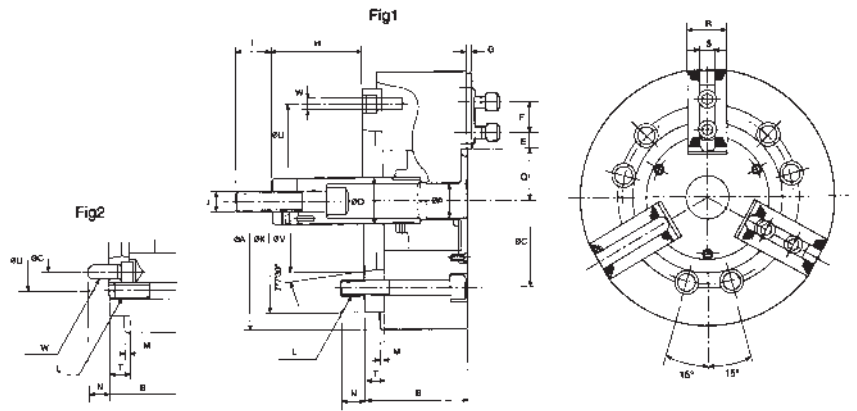

- Direct mounting: Direct mount for VA series chucks onto short taper spindle of ASA and JIS standards.
- High performance: Similar high performance to V series.
- Chuck mounting screws: Metric or UNC socket head cap screws are supplied for bolting the chuck to the spindle.
- Alternative spindle adaptors: ASA or DIN adaptors can be supplied to fit machine spindle.

SPECIFICATIONS

Unit:mm

Dim	ORDER NO.	V-206A5	V-208A6	V-210A6	V-210A8	V-212A8	V-215A8	V-215A11
Jaw Stroke (mm)		9.2	9.7	8.8	8.8	10.5	16	16
Plunger Stroke (mm)		20	21	25	25	30	35	35
Max. Pull Force (kgf)		1835	2549	2957	2957	4181	8362	8362
Max. Gripping Force (kgf)		5253	7548	10013	10013	15807	25391	25391
Max. Operating Pressure (kgf/cm ²)		25.5	24.5	28.6	28.6	27.5	30.6	30.6
Max. Speed (r.p.m.)		5000	4000	3500	3500	3000	2800	2800
Weight (kgs)		12.5	24.4	40.65	37.15	61.75	105	103
Moment of Inertia I (kgf.m ²)		0.045	0.317	0.3	0.3	0.725	1.8	1.8
Matching Cylinder		MS105 MH100	MS125 MH125	MS125 MH125	MS125 MH125	MS150 MH150	MS150 MH150	MS200 MH200
Matching Soft Jaw		VHC06	VHC08	VHC10	VHC10	VHC12-1	VHC15-1	VHC15-1
Matching Hard Jaw		HJ06	HJ08	HJ10	HJ10	HJ12-1	HJ15-1	HJ15-1
CODE NO.		5002-090	5002-091	5002-092	5002-093	5002-094	5002-095	5002-096

DIMENSIONS

Unit:mm

Dim	ORDER NO.	V-206A5	V-208A5	V-208A6	V-210A6	V-210A8	V-212A8	V-215A8	V-215A11
A		165	210	210	254	254	304	381	381
B		84	103	97	109	102	118	141	130
C		104.78	104.78	133.35	133.35	171.45	171.45	171.45	235
F		20	25	25	30	30	30	43	43
K		140	170	170	220	220	220	300	300
L		6-M10	6-M12	6-M12	6-M16	6-M16	6-M16	6-M16	6-M20
M		5	5	5	5	5	6	6	6
N		14	13	18	18	25	25	24	32
P		21	21	25	34	34	34	-	-
T		15	23	17	25	18	18	33	22
V		82.563	82.563	106.375	106.375	139.719	139.719	139.719	196.869
U		116	133.35	150	171.45	190	190	235	260
E max.		15.25	22.25	22.25	30.75	30.75	48.75	50.25	50.25
E min.		9.25	11.75	11.75	11.25	11.25	12.75	23.25	23.25
G		4	5	5	5	5	5	2	2
H max.		89.6	109	115	133	140	145	71	82
H min.		69.6	88	94	108	115	115	36	47
I		36	36	36	36	36	36	55	55
J		M16x2.0	M20x2.5	M20x2.5	M20x2.5	M20x2.5	M20x2.5	M30x3.5	M30x3.5
O		34	38	38	45	45	50	60	60
Q max.		38.7	46.75	46.3	51.1	51.1	61	77.5	77.5
Q min.		34.1	41.9	41.9	46.7	46.7	55.75	69.5	69.5
R		31	35	35	40	40	50	50	50
S		12	14	14	16	16	18	25.5	25.5
W		3-M6	6-M10	3-M6	6-M12	6-M8	6-M8	6-M16	3-M10
REFER FIG.		Fig-1	Fig-2	Fig-1	Fig-2	Fig-1	Fig-1	Fig-2	Fig-1



Super High Speed Through Hole Rotary Hydraulic Cylinder

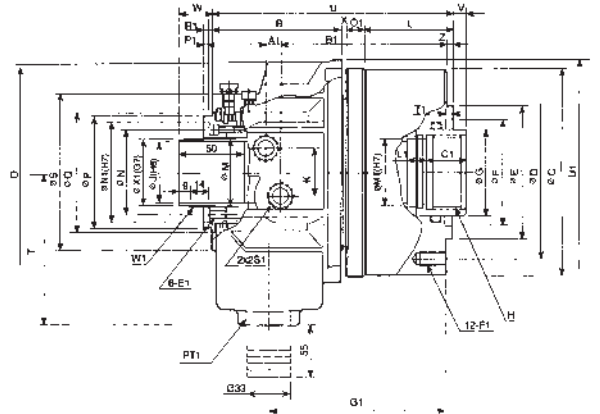
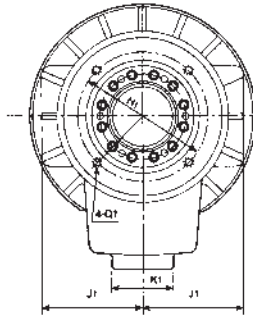
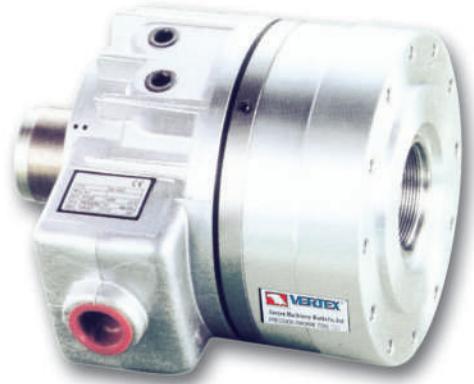

- Small-sized light weight:
Comparing with the traditional product, it is small-sized (reduced to MAX 95mm) and a light weight (weighted MAX 4.5kgs). Make its capacity more stable to reduce the burden of the machinery at high speed turning.
- The most largest bore:
Comparing with the old product, it has about 20% more bore full diameter for utilizing the capacity of machinery.
- The safety mechanism:
It can retain the gripping force with a check valve.

SPECIFICATIONS

ORDER NO.	Dim Piston Dia. (mm)	Piston Area		Piston Stroke (mm)	Max. Draw Bar Pull Force		Max. Operating Pressure (kgf/cm ²)	Max. Speed (r.p.m.)	Moment Inertia (kgf.m ²)	Weight (kgs)	Total Leakage (l/min)	CODE NO.
		Push Side (cm ²)	Pull Side (cm ²)		Push Side KN (kgs)	Pull Side KN (kgs)						
M1036	105	71	68.5	15	24.8(2529)	24(2447)	40.8	8000	0.011	8.6	3.0	5003-001
M1236	125	100	89	15	38(3875)	33(3365)	40.8	7000	0.019	13.0	3.0	5003-002
M1246	125	100	89	15	38(3875)	33(3365)	40.8	7000	0.019	12.0	3.0	5003-003
M1546	155	161	150	22	60(6118)	56(5710)	40.8	6200	0.052	18	3.9	5003-004
M1552	155	161	150	22	60(6118)	56(5710)	40.8	6200	0.052	16.8	3.9	5003-005
M1868	180	198	183	25	75(7546)	69(7036)	40.8	4700	0.095	28.0	4.2	5003-006
M1875	180	198	183	25	75(7546)	69(7036)	40.8	4700	0.095	26.0	4.2	5003-007
M2091	205	252	234	30	94(9585)	88(8973)	40.8	3800	0.15	37.0	4.5	5003-008
M2511	250	348	336	23	124(12644)	120(12236)	40.8	2800	0.45	57	7.0	5003-009

DIMENSIONS

ORDER NO.	Dim																				
	C1	E1	F1	G1	H1	J1	K1	L1	M1	N1	O1	P1	Q1	R1	S1	T1	U1	W1	X1	B	C
M1036	25	M5x0.8	M10x1.5	126	88	68	53	15	38	64	14	4	M5x0.8	4	PT3/8"	6	136	M44x1.5	42	101	136
M1236	30	M6x1.0	M10x1.5	135	98	76	47	15	38	76	14	4	M5x0.8	6	PT1/2"	6	169	M52x1.5	50	99	154.5
M1246	30	M6x1.0	M10x1.5	135	98	76	47	15	50	76	14	4	M5x0.8	6	PT1/2"	6	169	M52x1.5	50	99	154.5
M1546	30	M6x1.0	M10x1.5	145	110	86	47	15	50	85	14	4	M6x1.0	7	PT1/2"	6	187.5	M58x1.5	56	103	190
M1552	30	M6x1.0	M10x1.5	145	110	86	47	15	55	85	14	4	M6x1.0	7	PT1/2"	6	187.5	M58x1.5	56	103	190
M1868	35	M6x1.0	M10x1.5	166.5	155	101	47	15	70	108	16	4	M6x1.0	7	PT1/2"	6	220	M84x2	81	126	215
M1875	35	M6x1.0	M10x1.5	166.5	155	101	47	15	80	108	16	4	M6x1.0	7	PT1/2"	6	220	M84x2	81	126	215
M2091	35	M6x1.0	M12x1.75	183	165	110	47	15	95	120	16	4	M6x1.0	7	PT1/2"	6	267	M99x2	96	141	240
M2511	45	M6x1.0	M16x2.0	197	206	129	55	20	123	160	18	4	M6x1.0	7	PT1/2"	6	294		134.6	186	310

ORDER NO.	Dim																							
	D	E	F	G	H	J	K	L	M	N	O	P	Q	S	T	U	V max	V mix	W max	W mix	X	Z	A1	B1
M1036	115	100	65	48	M42x1.5	36	32	62	44.6	54	126	73	80	104	115	179.5	10	-5	39	24	2.5	5	11	120.5
M1236	130	100	80	65	M42x1.5	36	36	67	52.6	64	166	85	90	118	114	184	10	-5	40	25	4	5	11	126.5
M1246	130	100	80	65	M55x2	46	36	67	52.6	64	166	85	90	118	114	184	10	-5	40	25	4	5	11	126.5
M1546	170	130	85	70	M55x2	46	36	75	59.6	73	184	96	102	137	130	196	17	-5	47	25	4	5	11	136
M1552	170	130	85	70	M60x2	52	36	75	59.6	73	184	96	102	137	130	196	17	-5	47	25	4	5	11	136
M1868	190	160	120	95	M75x2	68	36	84	84.6	98	215	121	131	166	160	230	20	-5	50	25	4	5	17.5	153.5
M1875	190	160	120	95	M85x2	75	36	84	84.6	98	215	121	131	166	160	230	20	-5	50	25	4	5	17.5	153.5
M2091	215	180	140	110	M100x2	91	36	93	99.6	108	264	138	148	182	185	253	25	-5	55	25	3	5	21	168
M2511	275	230	166	140	M130x2	117.5	36	89	134.6	148	362	178		232	215	296	18	-5	38	15	3	6	27	184.5



Non Through Hole Rotary Hydraulic Cylinder (With Valves)



• Built-in safty check valves.

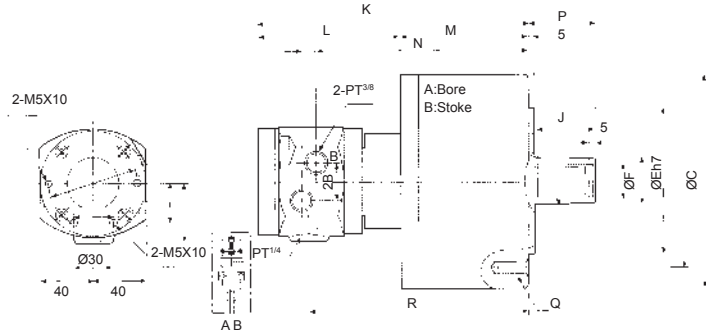

DIMENSIONS

ORDER NO.	Dim	A	B	C	D	E	F	G	H	J	K	L	M	N	P Max.	P Min.	Q	R	CODE NO.
		MS105	105	20	135	100	80	30	21	M20x2.5	35	197	108	89	152	45	25	6-M10x20	158
MS125	125	25	160	130	110	35	25	M24x3.0	44	205	108	97	160	51	26	6-M12x24	166	5003-031	
MS150	150	30	190	130	110	45	31	M30x3.5	45	214	108	106	169	56	26	12-M12x24	175	5003-032	
MS200	200	35	245	145	120	55	37	M36x4.0	60	228	108	122	183	69	34	12-M16x30	189	5003-033	

SPECIFICATIONS

ORDER NO.	Dim	Piston Area		Max. Draw Bar Pull Side KN (kgf)	Piston Stroke (mm)	Max. Speed (r.p.m.)	Max. Operating Pressure (kgf/cm ²)	Total Leakage (l/min)	Moment Inertia I (kgf.m ²)	Weight (kgs)
		Push Side (cm ²)	Pull Side (cm ²)							
MS105		86	79	29(2957)	20	6000	4.0(40.8)	0.8	0.0125	7.1
MS125		122	113	42(4283)	25	6000	4.0(40.8)	0.8	0.0225	10
MS150		176	160	60(6118)	30	5500	4.0(40.8)	0.8	0.0475	13.5
MS200		314	290	108(11013)	35	5500	4.0(40.8)	0.8	0.0975	22



4-Jaw Wedge Type Through Hole Power Chuck (Without Adaptor)

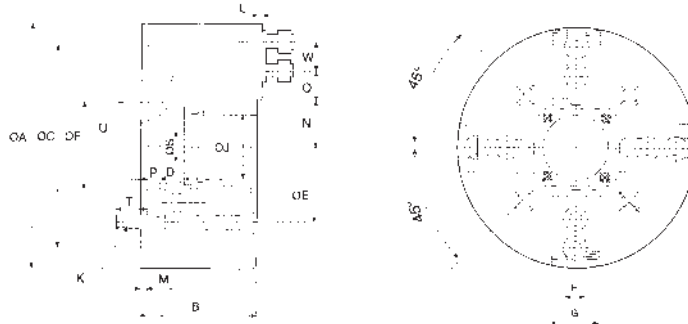

DIMENSIONS

ORDER NO.	A	B	C (H6)	D	E	M	G	H	J	K	L	F	N Max.	N Min.	O Max.	O Min.	P Max.	P Min.	S	T	U	W
VNIT-208	210	91	170	20.5	133.35	5	37	14	52	4-M12	2	66	38.7	35	29.75	14.75	14.5	1.5	30	20	M60x2	25
VNIT-210	254	100	220	25	171.45	5	42	16	75	4-M16	2	94	51	46.6	33.75	14.75	8.5	-10.5	45	22	M85x2	30
VNIT-212	304	110	220	28	171.45	6	52	21	91	4-M16	2	108	61.3	56	45.75	15.75	8	-15	50	23	M100x2	30
VNIT-215	381	133	300	43	235	6	62	24	117.5	4-M20	5	139	82	76.7	46.75	13.75	7	-16	60	30	M130x2	43

SPECIFICATIONS

ORDER NO.	Through-Hole (mm)	Plunger Stroke (mm)	Jaw Stroke (mm)	Max. Draw Bar Pull Force (kgf)	Max. Gripping Force (kgf)	Max. Speed (r.p.m.)	Weight (kgs)	Matching Cylinder	Max. Operating Pressure (kgf/cm ²)	CODE NO.
VNIT-208	Ø52	16	7.4	2294	5716	4900	24	M1552	17.3	5003-050
VNIT-210	Ø75	19	8.8	2906	7546	4200	36	M1875	18.4	5003-051
VNIT-212	Ø91	23	10.6	3739	9789	3300	58.5	M2091	18.4	5003-052
VNIT-215	Ø117.5	23	10.6	6828	12236	2500	114	M2511	15.3	5003-053

NEW



Lathe Collets
Please See E25

Please use
DIN6343 collets

collet illustration

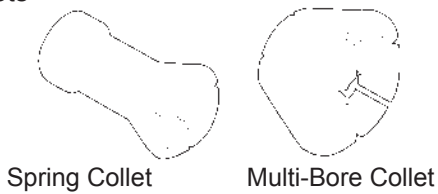

Spring Collet

Multi-Bore Collet

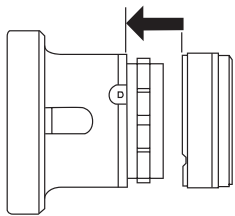
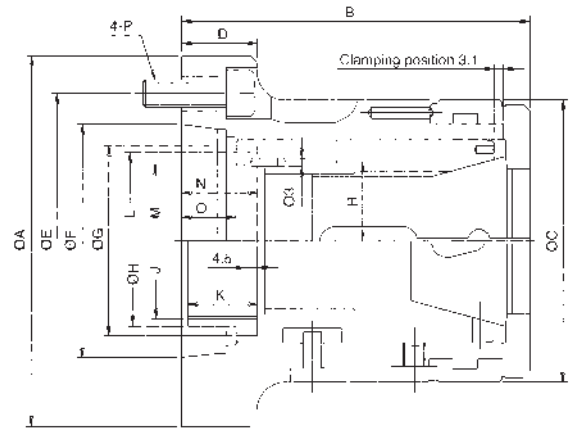

Push the cover

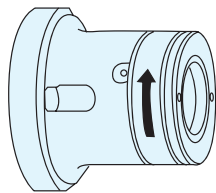

Turn the cover

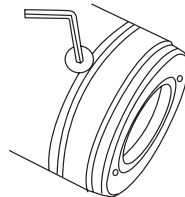

Tighten the cover anti rotation screws

Holding Range

CHUCK NO.	MULTIBORE			SPRING COLLET				
	CAT NO.	○	◇	□	CAT NO.	○	◇	□
CR42	M-673	42	36	30	173E/4728	42	36	30
CR60	M-677	60	52	42	185E/4291	60	52	42

DIMENSIONS

ORDER NO.	A	B	C	D	E	F	G	H	J Max.	K	L	M	N	O	P	R
CR42A5	135	124	100	27	104.78	82.563	M66xP1.5	60	M55xP20	25	62.5	54	27.4	19.4	M10	28
CR42A6	170	124	100	32	133.35	106.375	M66xP1.5	66	M60xP20	25	62.5	54	27.4	19.4	M12	28
CR60A6	170	145	130	27	133.35	106.375	M90xP1.5	67.5	M60xP20	30	83	77	29.9	21.9	M12	39.5

SPECIFICATIONS

ORDER NO.	Diameter of Shank	Material Diameter (mm)	Collet Travel Distance (mm)	Weight (kgs)	Maximum Bearing KN (kgf)	Maximum Holding Power KN (kgf)	Maximum Speed (r.p.m.)	CODE NO.
CR42A5	A2-5	42	7	6.2	25(2549)	55(5608)	6,000	5003-040
CR42A6	A2-6	42	7	8.2	25(2549)	55(5608)	6,000	5003-041
CR60A6	A2-6	60	7	13	33(3365)	59(6016)	5,000	5003-042



DIN6343

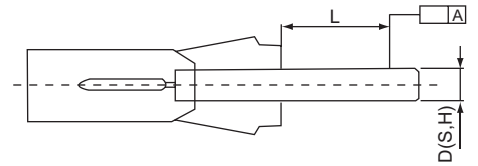
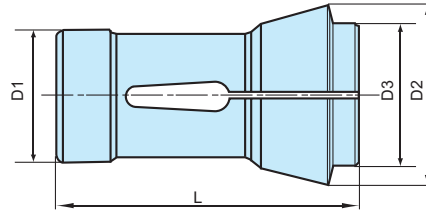

Test Bar	D (S,H)	L (mm)	A	
			Class 1	Class 2
0.2~1.0		3	0.015	0.015
1.0~1.6		6		0.020
1.6~3.0		10		
3.0~6.0		16		
6.0~10.0		25	0.020	0.030
10.0~18.0		40		
18.0~24.0		50		
24.0~30.0		60		
30.0~50.0		80	0.030	0.040
50.0~60.0		100		

DIN6343

COLLET TYPE	STANDARD NO.	D1 (mm)	D2 (mm)	D3 (mm)	L (mm)	KONUSWINKEL SPINDLE CONE ANGLE	COLLET RANGE(mm)		
							○	⬡	□
C-26	161E	32	45	34	75	15°	Ø3-Ø26	Ø6-Ø22	Ø5-Ø18
C-36	171E	42	55	42	94	15°	Ø36	Ø32	Ø26
C-42	173E	48	60	50	94	15°	Ø3-Ø42	Ø6-Ø36	Ø5-Ø30
C-52	177E	58	70	60	94	15°	Ø52	Ø45	Ø36
C-60	185E	66	84	73	110	15°	Ø3-Ø60	Ø6-Ø50	Ø5-Ø40
C-80	193E	90	107	92	130	15°	Ø3-Ø80	Ø6-Ø70	Ø5-Ø57

CONE SIZE

C80: Hex./Square shape order to make.

ROUND SHAPE / METRIC

METRIC SIZE

C26-DØ ○		C42-DØ ○		C60-DØ ○		C80-DØ ○	
ORDER NO.	CODE NO.	ORDER NO.	CODE NO.	ORDER NO.	CODE NO.	ORDER NO.	CODE NO.
C26-D6	5003-101	C42-D6	5003-131	C60-D8	5003-171	C80-D18	5003-211
C26-D8	5003-102	C42-D8	5003-132	C60-D9	5003-172	C80-D20	5003-212
C26-D9	5003-103	C42-D9	5003-133	C60-D10	5003-173	C80-D25	5003-213
C26-D10	5003-104	C42-D10	5003-134	C60-D11	5003-174	C80-D28	5003-214
C26-D11	5003-105	C42-D11	5003-135	C60-D12	5003-175	C80-D30	5003-215
C26-D12	5003-106	C42-D12	5003-136	C60-D13	5003-176	C80-D32	5003-216
C26-D13	5003-107	C42-D13	5003-137	C60-D14	5003-177	C80-D35	5003-217
C26-D14	5003-108	C42-D14	5003-138	C60-D15	5003-178	C80-D38	5003-218
C26-D15	5003-109	C42-D15	5003-139	C60-D16	5003-179	C80-D40	5003-219
C26-D16	5003-110	C42-D16	5003-140	C60-D17	5003-180	C80-D42	5003-220
C26-D17	5003-111	C42-D17	5003-141	C60-D18	5003-181	C80-D45	5003-221
C26-D18	5003-112	C42-D18	5003-142	C60-D19	5003-182	C80-D48	5003-222
C26-D19	5003-113	C42-D19	5003-143	C60-D20	5003-183	C80-D50	5003-223
C26-D20	5003-114	C42-D20	5003-144	C60-D21	5003-184	C80-D52	5003-224
C26-D21	5003-115	C42-D21	5003-145	C60-D22	5003-185		
C26-D22	5003-116	C42-D22	5003-146	C60-D23	5003-186		
C26-D23	5003-117	C42-D23	5003-147	C60-D24	5003-187		
C26-D24	5003-118	C42-D24	5003-148	C60-D25	5003-188		
C26-D25	5003-119	C42-D25	5003-149	C60-D27	5003-189		
		C42-D27	5003-150	C60-D28	5003-190		
		C42-D28	5003-151	C60-D30	5003-191		
		C42-D30	5003-152	C60-D32	5003-192		
		C42-D32	5003-153	C60-D34	5003-193		
		C42-D34	5003-154	C60-D36	5003-194		
		C42-D36	5003-155	C60-D38	5003-195		
		C42-D38	5003-156	C60-D40	5003-196		
		C42-D40	5003-157	C60-D42	5003-197		
		C42-D42	5003-158	C60-D45	5003-198		
				C60-D47	5003-199		
				C60-D48	5003-200		
				C60-D50	5003-201		

HEX. SHAPE / METRIC		METRIC SIZE			
C26-H		C42-H		C60-H	
ORDER NO.	CODE NO.	ORDER NO.	CODE NO.	ORDER NO.	CODE NO.
C26-H8	5003-241	C42-H8	5003-261	C60-H8	5003-281
C26-H10	5003-242	C42-H10	5003-262	C60-H10	5003-282
C26-H12	5003-243	C42-H12	5003-263	C60-H12	5003-283
C26-H13	5003-244	C42-H13	5003-264	C60-H13	5003-284
C26-H15	5003-245	C42-H15	5003-265	C60-H15	5003-285
C26-H16	5003-246	C42-H16	5003-266	C60-H16	5003-286
C26-H17	5003-247	C42-H17	5003-267	C60-H17	5003-287
C26-H19	5003-248	C42-H19	5003-268	C60-H19	5003-288
C26-H20	5003-249	C42-H20	5003-269	C60-H20	5003-289
C26-H21	5003-250	C42-H21	5003-270	C60-H21	5003-290
		C42-H22	5003-271	C60-H22	5003-291
		C42-H24	5003-272	C60-H24	5003-292
		C42-H25	5003-273	C60-H25	5003-293
		C42-H27	5003-274	C60-H27	5003-294
		C42-H30	5003-275	C60-H30	5003-295

DIN6343

COLLET TYPE	STANDARD NO.
C-26	161E
C-42	173E
C-60	185E
C-80	193E

ROUND SHAPE / INCH		INCH SIZE					
C26-DØ		C42-DØ		C60-DØ		C80-DØ	
ORDER NO.	CODE NO.	ORDER NO.	CODE NO.	ORDER NO.	CODE NO.	ORDER NO.	CODE NO.
C26-D ¹ / ₄ "	5003-301	C42-D ¹ / ₄ "	5003-321	C60-D ³ / ₈ "	5003-351	C80-D ³ / ₄ "	5003-381
C26-D ³ / ₈ "	5003-302	C42-D ³ / ₈ "	5003-322	C60-D ¹ / ₂ "	5003-352	C80-D ⁷ / ₈ "	5003-382
C26-D ¹ / ₂ "	5003-303	C42-D ¹ / ₂ "	5003-323	C60-D ⁵ / ₈ "	5003-353	C80-D1"	5003-383
C26-D ⁵ / ₈ "	5003-304	C42-D ⁵ / ₈ "	5003-324	C60-D ³ / ₄ "	5003-354	C80-D1 ¹ / ₈ "	5003-384
C26-D ³ / ₄ "	5003-305	C42-D ³ / ₄ "	5003-325	C60-D ⁷ / ₈ "	5003-355	C80-D1 ¹ / ₄ "	5003-385
C26-D ⁷ / ₈ "	5003-306	C42-D ⁷ / ₈ "	5003-326	C60-D1"	5003-356	C80-D1 ³ / ₈ "	5003-386
C26-D1"	5003-307	C42-D1"	5003-327	C60-D1 ¹ / ₈ "	5003-357	C80-D1 ¹ / ₂ "	5003-387
		C42-D1 ¹ / ₈ "	5003-328	C60-D1 ¹ / ₄ "	5003-358	C80-D1 ⁵ / ₈ "	5003-388
		C42-D1 ¹ / ₄ "	5003-329	C60-D1 ³ / ₈ "	5003-359	C80-D1 ³ / ₄ "	5003-389
		C42-D1 ³ / ₈ "	5003-330	C60-D1 ¹ / ₂ "	5003-360	C80-D1 ⁷ / ₈ "	5003-390
		C42-D1 ¹ / ₂ "	5003-331	C60-D1 ⁵ / ₈ "	5003-361	C80-D2"	5003-391
		C42-D1 ⁵ / ₈ "	5003-332	C60-D1 ³ / ₄ "	5003-362	C80-D2 ¹ / ₈ "	5003-392
				C60-D1 ⁷ / ₈ "	5003-363	C80-D2 ¹ / ₄ "	5003-393
				C60-D2"	5003-364	C80-D2 ³ / ₈ "	5003-394
						C80-D2 ¹ / ₂ "	5003-395
						C80-D2 ⁵ / ₈ "	5003-396
						C80-D2 ⁷ / ₈ "	5003-397
						C80-D3"	5003-398

LATHE COLLET

HEX. SHAPE / INCH		INCH SIZE			
C26-H		C42-H		C60-H	
ORDER NO.	CODE NO.	ORDER NO.	CODE NO.	ORDER NO.	CODE NO.
C26-H ¹ / ₄ "	5003-411	C42-H ³ / ₈ "	5003-431	C60-H ³ / ₈ "	5003-451
C26-H ³ / ₈ "	5003-412	C42-H ¹ / ₂ "	5003-432	C60-H ¹ / ₂ "	5003-452
C26-H ¹ / ₂ "	5003-413	C42-H ⁵ / ₈ "	5003-433	C60-H ⁵ / ₈ "	5003-453
C26-H ⁵ / ₈ "	5003-414	C42-H ³ / ₄ "	5003-434	C60-H ³ / ₄ "	5003-454
C26-H ³ / ₄ "	5003-415	C42-H ⁷ / ₈ "	5003-435	C60-H ⁷ / ₈ "	5003-455
C26-H ⁷ / ₈ "	5003-416	C42-H1"	5003-436	C60-H1"	5003-456
		C42-H1 ¹ / ₈ "	5003-437	C60-H1 ¹ / ₈ "	5003-457
		C42-H1 ¹ / ₄ "	5003-438	C60-H1 ¹ / ₄ "	5003-458
				C60-H1 ³ / ₈ "	5003-459



SQUARE SHAPE / INCH		INCH SIZE			
C26-S		C42-S		C60-S	
ORDER NO.	CODE NO.	ORDER NO.	CODE NO.	ORDER NO.	CODE NO.
C26-S ¹ / ₄ "	5003-471	C42-S ³ / ₈ "	5003-491	C60-S ³ / ₈ "	5003-501
C26-S ³ / ₈ "	5003-472	C42-S ¹ / ₂ "	5003-492	C60-S ¹ / ₂ "	5003-502
C26-S ¹ / ₂ "	5003-473	C42-S ⁵ / ₈ "	5003-493	C60-S ⁵ / ₈ "	5003-503
C26-S ⁵ / ₈ "	5003-474	C42-S ³ / ₄ "	5003-494	C60-S ³ / ₄ "	5003-504
		C42-S ⁷ / ₈ "	5003-495	C60-S ⁷ / ₈ "	5003-505
				C60-S1"	5003-506
				C60-S1 ¹ / ₈ "	5003-507

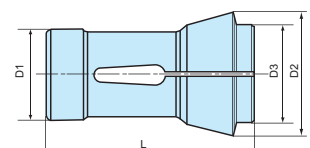



For Internal Grinding

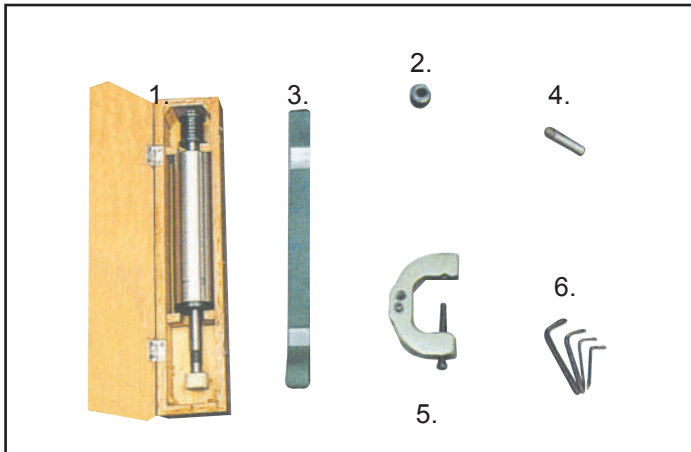
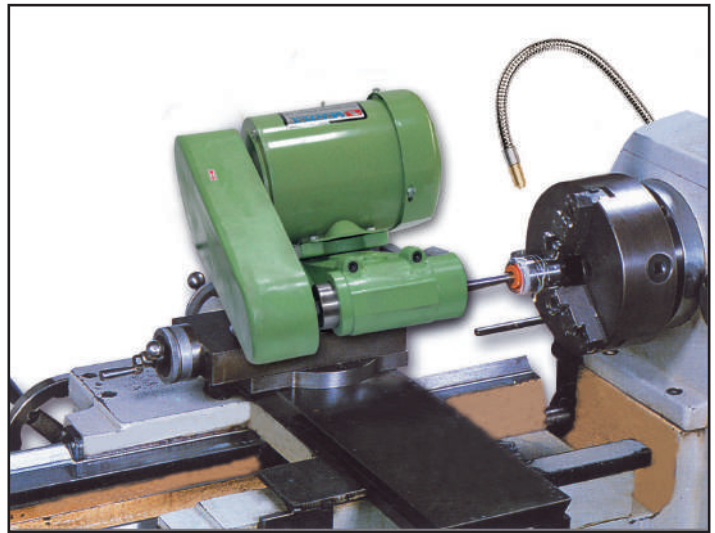

Standard Accessories

1. Internal Spindle	1
2. Pulley for Internal Grinding	2
3. Flat Belt	1
4. Diamond tool	1
5. Holder for Diamond Tool	1
6. key Folds (8, 5, 3, 2mm)	4

- ※ VGR-175, VGR-185 WITHOUT INTERNAL SPINDLE
- ※ ECOMICAL TYPE FOR LIGHT DUTY ONLY
- ※ 220V/3 PH, 380V/3PH
- ※ COLOR & SHAPE MAY VARY..

※ **Guaranteed for 3 months**

Characteristic Features

- Both the main shafts have been specially designed, and the world-wide precision bearing is used to fit the main shafts which are made of alloy steel heat-treated for high wear resistance, precision, as well as maintaining to the lowest temperature for durability and stability.
- The motor base and the spindle bushing are adjustable.
- The motor is well designed with a special and nice appearance, The R.P.M. of this motor varied depending on the size of the workpiece.
- This grinder is capable of grinding the work piece to a minimum of 3 mm in outer diameter and from 2mm up in inner diameter (bore) with the accuracy within 0.003mm and a well finished surface. (supplied with special attachments).
- The spindle bushing is made of cast iron, and supported by three surfaces. Therefore, it is durable and elastic.
- Materials such as steel, iron, copper (brass), aluminum, cast iron, plastics, procelain, marble, regardless of being heat treated or not, can be ground on this machine which functions lie a cylindrical grinder. So it may lower the cost of the production.

We assure you of high quality products.

※ Types of Grinding For Work Pieces

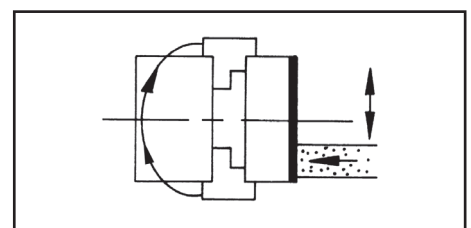
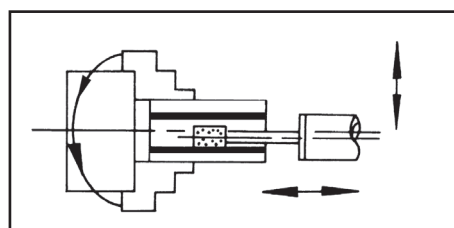
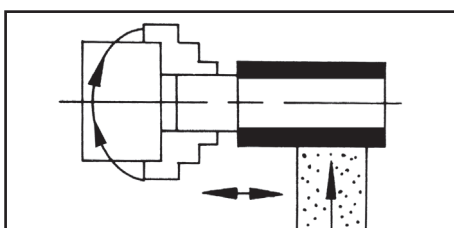

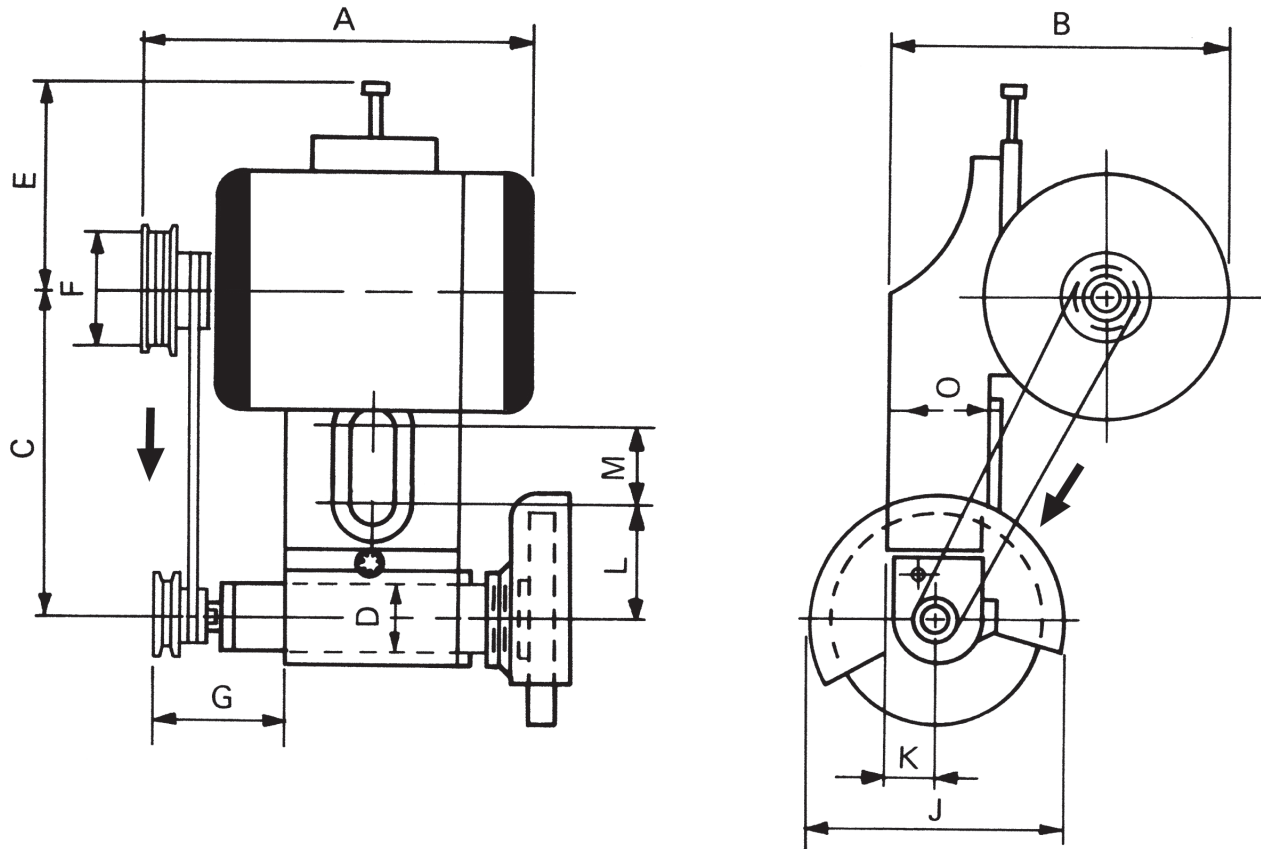

※ CLOCR MAY VARY
 ※ NOT FOR HIGH PRECISION GRINDING

ORDER NO.	Main Dimension. (mm)												Net Weight (kgs)	Packing Size (mm)
	A	B	C	D	E	F	G	J	K	L	M	O		
VGR-165	280	275	260-310	50	160	110	65	230	40-65	105	40	85	48	520x430x350
VGR-150	280	275	250-300	48	160	110	65	150	40-65	105	40	85	38	520x430x350
VGR-125	270	230	230-280	48	-	110	65	150	34-58	90	15	75	35	520x430x350
VGR-100	235	200	170	40	-	110	50	150	28	45	10	64	24	450x320x340

ORDER NO.	HP	External Spindle		Internal Spindle				Grinder on Lathe (Length of Bed of Lathe) Ft.	For Swing m/m	CODE NO.		
		Size of Wheel dia x width-hole	(R.P.M.) Non-load Speed	Diameter to be ground	Size of Wheel dia x width x hole	(R.P.M.) Non-load Speed	Grinding Depth (mm)					
VGR-165	1	8"x3/4"x3/4"	3000 3700	2490 3070	25-50	1"x3/8"x1/4"	20000 13500	16800 11500	70	8-10	650-1600	5004-003
VGR-150	1	5"x5/8"x5/8"	4500 6000	3750 5000	19-40	1"x3/8"x1/4"	20000 13500	16800 11500	70	6-8	550-900	5004-004
VGR-125	1/2	5"x5/8"x5/8"	4500 6000	3750 5000	19-40	1"x3/8"x1/4"	20000 13500	16800 11500	70	4-6	430-850	5004-005
VGR-100	1/4	5"x5/8"x5/8"	4500 6000	3750 5000	19-40	1"x3/8"x1/4"	20000 13500	16800 11500	50	under 4	320-400	5004-006



VDI Tool Holders

Coupling Type System



VERTEX®

DIN69880

A DIN 1809 (For DUPLOMATIC)

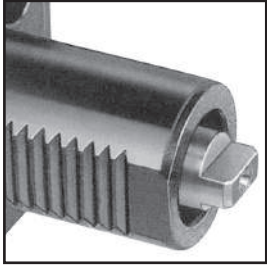

Coupling to DIN 1809

B DIN 5480 (For SAUTER/DUPLOMATIC)

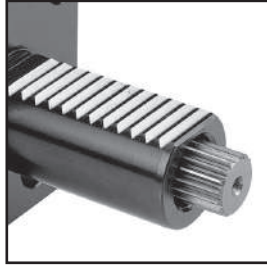

Coupling to DIN 5480

C DIN 5482 (For SAUTER/DUPLOMATIC)

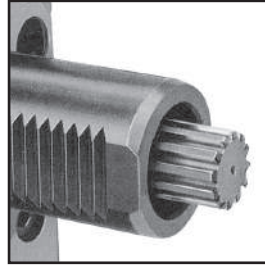

Coupling to DIN 5482

D MT (For BARUFFALDI)

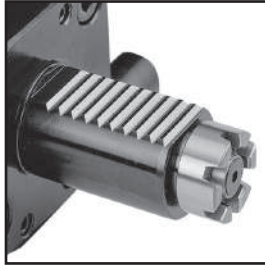

Spur Coupling

E IT (For DUPLOMATIC)

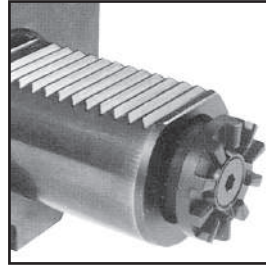

Spur Coupling



VDI Tool Holders

Tool Holders Direction System

DIN69880

A: Axial Direction

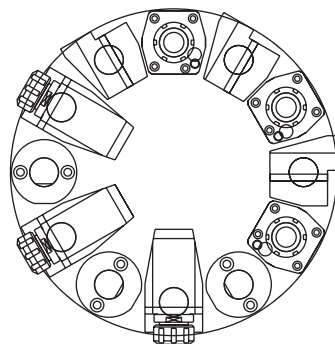
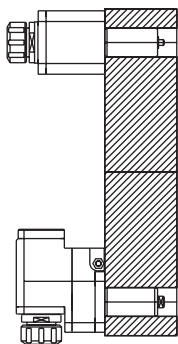

B: Radial Direction (Star Turret)

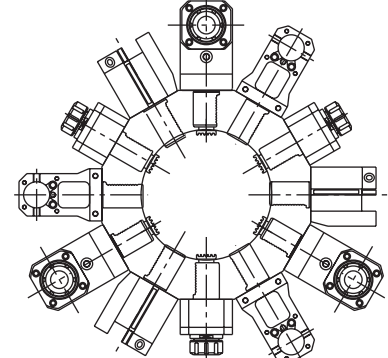
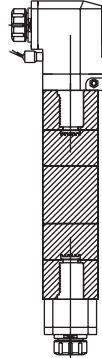

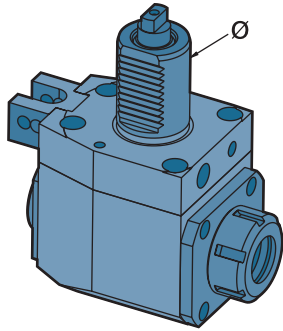

DA

Stright Direct Drive

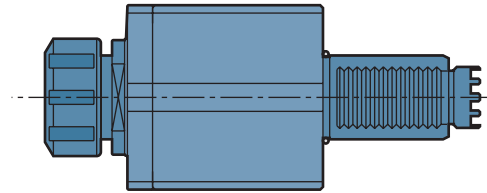

	VDI 20	VDI 30	VDI 40	VDI 50
SHAFT DIA.	20	30	40	50

BR

B: backward
R: right hand

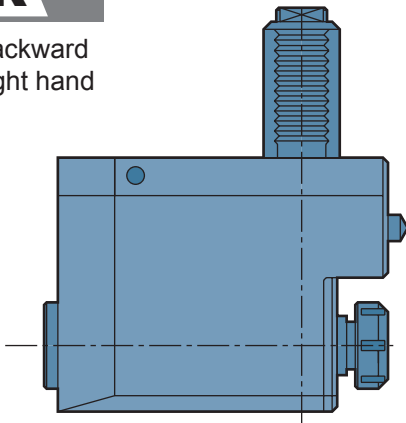

BL

B: backward
L: left hand

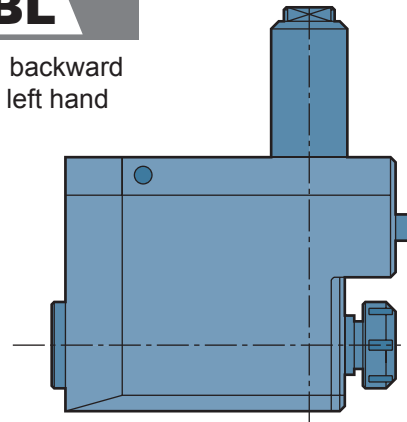

FR

F: forward
R: right hand

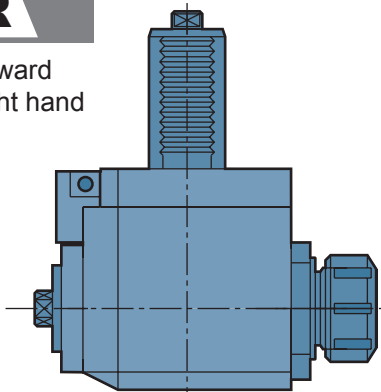

FL

F: forward
L: left hand

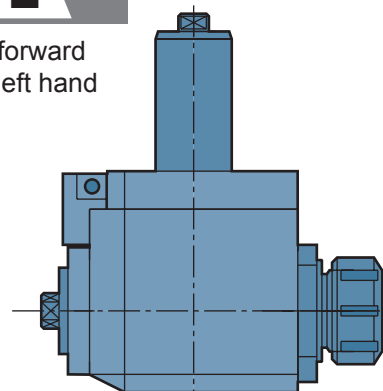

TXX

T: Tapping

EX:

- BR4018093290 it's VDI 40, right hand, coupling type 1809, backward come with ER 32 nut. P.C.D. is 90mm
 - FL3054822555 it's VDI 30 left hand coupling type 5482 (B15x12) forward, come with ER 25 nut. P.C.D. is 55mm
- ※ ORDER MADE, NOT REFUNDABLE.

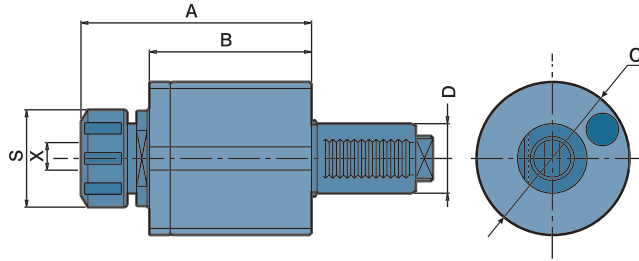
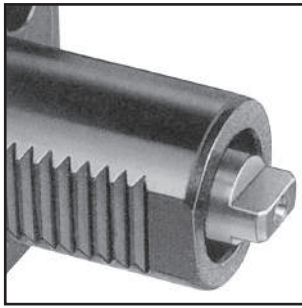

Power Transmission According
To DIN 1809

- External coolant supply
- Collet is not included
- To be used for collet DIN 6499

DIMENSIONS

ORDER NO.	D DIN 69880	X Capacity	S	Maximum R.P.M.	i	A	B	C	CODE NO.
DA20180916	20	1-10 ER16	32	6000	1 : 1	77	49	58	5006-001
DA30180925	30	1-16 ER25	42	6000	1 : 1	101	70	68	5006-002
DA40180932	40	2-20 ER32	50	6000	1 : 1	111	73.5	86	5006-003
DA50180940	50	3-26 ER40	63	6000	1 : 1	120	81.5	96	5006-004
DA60180950	60	10-34 ER50	78	6000	1 : 1	140	88.5	116	5006-005



Axial Tapping Heads

DIMENSIONS

ORDER NO.	D DIN 69880	X Capacity	S	Maximum R.P.M.	i	A	B	C	CODE NO.
TDA30180916	30	1-10 ER16	30	3000	1 : 1	108	71.5	68	5006-006
TDA40180920	40	1-13 ER20	35	3000	1 : 1	95.5	55	86	5006-007
TDA50180925	50	1-16 ER25	42	3000	1 : 1	123	81.5	96	5006-008
TDA60180932	60	2-20 ER32	50	3000	1 : 1	158.5	88.5	116	5006-009



Axial Milling Heads

DIN 1809

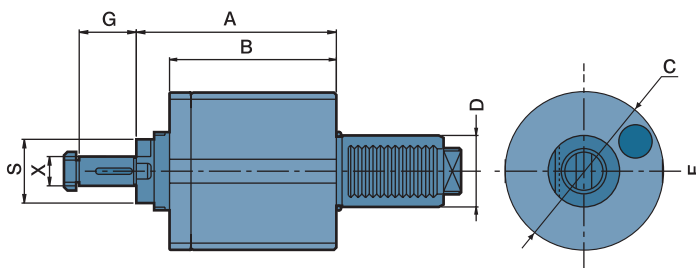

- External coolant and intermediate rings supply
- To be used for cutter arbor according to DIN 6358

DIMENSIONS

ORDER NO.	D DIN 69880	X Capacity	S	Maximum R.P.M.	i	A	B	C	G	CODE NO.
DA30180916C	30	16	32	3000	1 : 1	91.5	70	68	27	5006-010
DA40180922C	40	22	40	3000	1 : 1	86.5	73.5	86	31	5006-012
DA50180922C	50	22	40	3000	1 : 1	117	81.5	96	31	5006-013
DA50180927C	50	27	40	3000	1 : 1	117	81.5	96	33	5006-014



Radial Drilling And Milling Heads-Back Ward Type



MODE: BL
LEFT-HAND

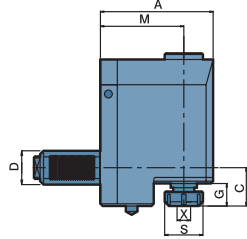
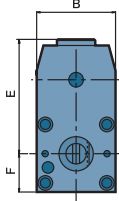

MODE: BR
RIGHT-HAND

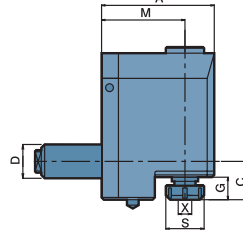
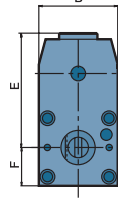

DIN 1809

- External coolant supply
- Collet is not included
- To be used for collet DIN 6499

DIMENSIONS

ORDER NO.	D DIN 69880	X Capacity	S	Maximum R.P.M.	i	A	B	C	E	F	G	M	CODE NO.
BR2018091660 BL2018091660	20	1-10 ER16	30	5000	1 : 1	83	50	35	70	27	27	60	5006-015A
BR3018092572 BL3018092572	30	1-16 ER25	42	5000	1 : 1	95	60	41.5	75.5	31.5	29	72	5006-016A
BR4018093290 BL4018093290	40	2-20 ER32	50	5000	1 : 1	124	80	44	110	42	34	90	5006-017
BR5018094090 BL5018094090	50	3-26 ER40	63	5000	1 : 1	129	86	49	112	45	39	90	5006-018
BR60180950106 BL60180950106	60	10-34 ER50	78	5000	1 : 1	154	104	74.5	123	54	52	106	5006-019A



Radial Tapping Heads-Back Ward Type

DIMENSIONS

DIN 1809

ORDER NO.	D DIN 69880	X Capacity	S	Maximum R.P.M.	i	A	B	C	E	F	G	M	CODE NO.
TBR3018091672 TBL3018091672	30	1-10 ER16	30	3000	1 : 1	95	60	44	75.5	31.5	32	72	5006-020A
TBR4018092090 TBL4018092090	40	1-13 ER20	35	3000	1 : 1	124	80	59.5	110	42	49.5	90	5006-021
TBR5018092590 TBL5018092590	50	1-16 ER25	42	3000	1 : 1	129	86	54	112	45	36	90	5006-022
TBR60180932106 TBL60180932106	60	2-20 ER32	50	3000	1 : 1	154	104	105	123	54	82.5	106	5006-023A



Radial Drilling And Milling Heads

※ ORDER MADE, NOT REFUNDABLE.

DIN 1809

MODE: FL
LEFT-HAND

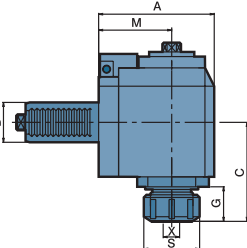
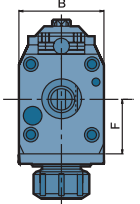

MODE: FR
RIGHT-HAND

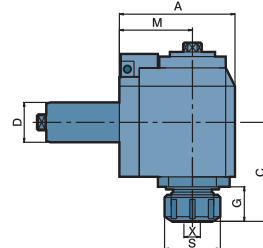
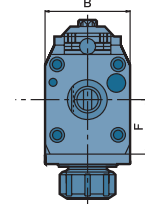

- To be used for collet DIN 6499
- Collet is not included
- External coolant supply

DIMENSIONS

ORDER NO.	D DIN 69880	X Capacity	S	Maximum R.P.M.	i	A	B	C	F	G	M	CODE NO.
FR3018092555 FL3018092555	30	1-16 ER25	42	5000	1 : 1	87	64	74.5	34	26	55	5006-024
FR4018093265 FL4018093265	40	2-20 ER32	50	5000	1 : 1	99	80	71	40	23	65	5006-025
FR5018094075 FL5018094075	50	3-26 ER40	63	5000	1 : 1	115	88	101	56	34	75	5006-026



Radial Tapping Heads

DIMENSIONS

DIN 1809

ORDER NO.	D DIN 69880	X Capacity	S	Maximum R.P.M.	i	A	B	C	F	G	M	CODE NO.
TFR3018091655 TFL3018091655	30	1-10 ER16	30	3000	1 : 1	87	64	75	41	30	55	5006-027
TFR4018092065 TFL4018092065	40	1-13 ER20	35	3000	1 : 1	99	80	93.5	40	46	65	5006-028
TFR5018092575 TFL5018092575	50	1-16 ER25	42	3000	1 : 1	115	88	103	56	42	75	5006-029



Axial Drilling And Milling Heads



OFFSET

DIN 1809

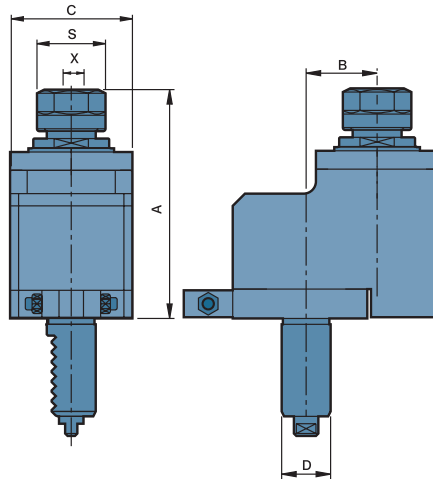

- Collet is not included
- To be used for collet DIN 6499
- External coolant supply

DIMENSIONS

i is speed ratio example:1:2. It's 2 times of speed

ORDER NO.	D DIN 69880	X Capacity	S	Maximum R.P.M.	i	A	B	C	CODE NO.
DA2018091629	20	1-10 ER16	30	4000	1 : 1	93.5	29	50	5006-030
DA3018092529	30	1-16 ER25	42	4000	1 : 1	100	29	60	5006-031
DA3018092529/1	※30	1-16 ER25	42	8000	1 : 2	100	29	60	5006-032
DA4018093250	40	2-20 ER32	50	4000	1 : 1	125.5	50	75	5006-033
DA5018094065	50	3-26 ER40	63	3000	1 : 1	124	65	86	5006-034



Radial Milling Heads

DISK CUTTER UNITS

※ ORDER MADE, NOT REFUNDABLE. DIN 1809

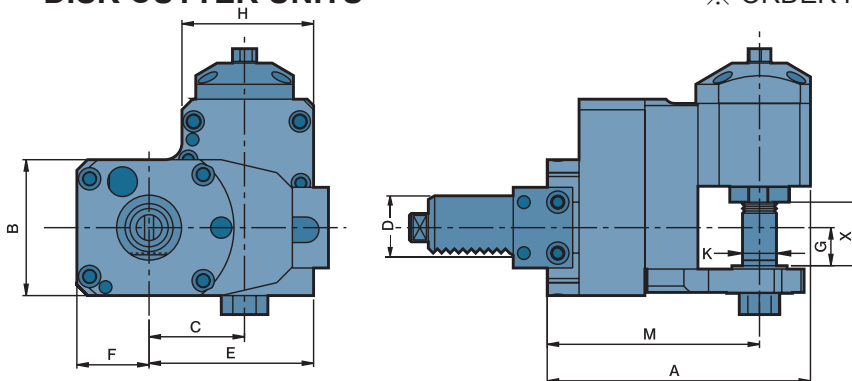

- External coolant supply

DIMENSIONS

i;(3:1),It's 3 times of speed decrease

ORDER NO.	D DIN 69880	X Capacity	Maximum R.P.M.	i	A	B	C	E	F	G	H	K	M	CODE NO.
BR30180916C/3 BL30180916C/3	30	16	3000	3 : 1	133	64	45	77.5	49	5	65	16	107.5	5006-035



Angular Heads

THE ANGLE IS ADJUSTED

DIN 1809

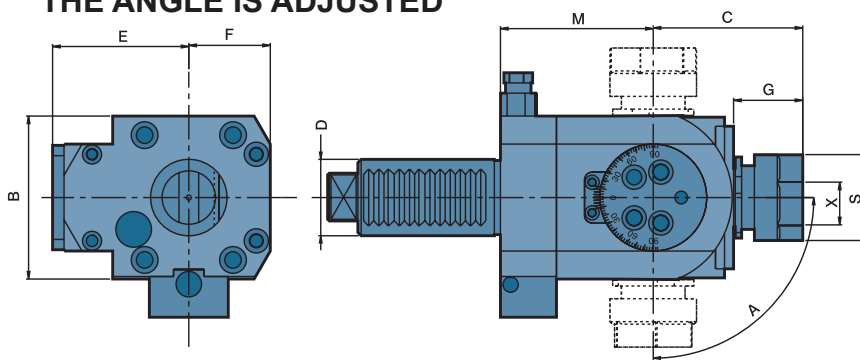

- To be used for collet DIN 6499
- External coolant supply
- Collet is not included

DIMENSIONS

ORDER NO.	D DIN 69880	X Capacity	S	Maximum R.P.M.	i	A	B	C	E	F	G	M	CODE NO.
DA30180920B	30	1-13 ER20	35	4000	1 : 1	±90°	64	59	54	32	27	60	5006-036A

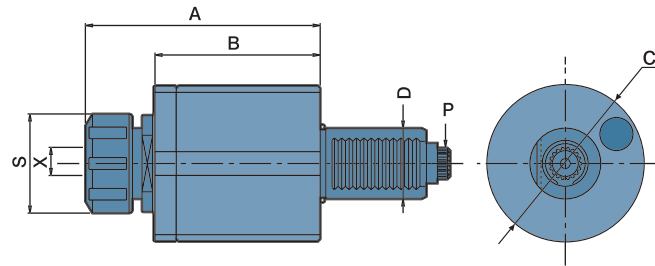
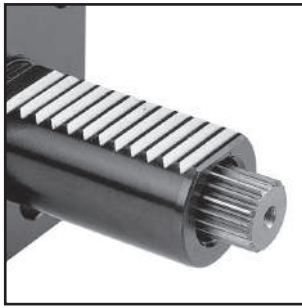

Power Transmission According To DIN 5480

- External coolant supply
- To be used for collet DIN 6499
- Collet is not included

DIMENSIONS

ORDER NO.	D DIN 69880	X Capacity	S	Maximum R.P.M.	i	A	B	C	P DIN 5480	CODE NO.
DA30548025	30	1-16 ER25	42	6000	1 : 1	101	70	68	W16X0.8	5006-037
DA40548032	40	2-20 ER32	50	6000	1 : 1	111	75	86	W20X0.8	5006-038
DA50548040	50	3-26 ER40	63	6000	1 : 1	122	82	96	W24X1.25	5006-038A

Axial Tapping Heads

DIN 5480

DIMENSIONS

ORDER NO.	D DIN 69880	X Capacity	S	Maximum R.P.M.	i	A	B	C	P DIN 5480	CODE NO.
TDA30548016	30	1-10 ER16	30	3000	1 : 1	108	71.5	68	W16X0.8	5006-039A
TDA40548020	40	1-13 ER20	35	3000	1 : 1	95.5	55	86	W20X0.8	5006-040A



Axial Milling Heads

DIN 5480

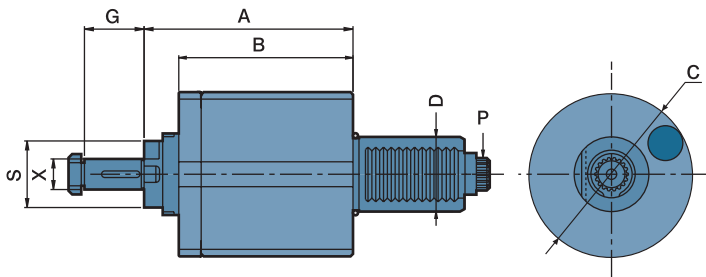

- To be used for cutter arbor according to DIN 6358
- External coolant and intermediate rings supply

DIMENSIONS

ORDER NO.	D DIN 69880	X Capacity	S	Maximum R.P.M.	i	A	B	C	G	P DIN 5480	CODE NO.
DA30548016C	30	16	32	3000	1 : 1	91.5	70	68	27	W16X0.8	5006-041
DA40548016C	40	16	32	3000	1 : 1	68.5	55	86	27	W20X0.8	5006-042
DA40548022C	40	22	32	3000	1 : 1	68.5	55	86	31	W20X0.8	5006-043



Radial Drilling And Milling Heads-Backward Type



※ ORDER MADE, NOT REFUNDABLE.

MODE: BL
LEFT-HAND

MODE: BR
RIGHT-HAND

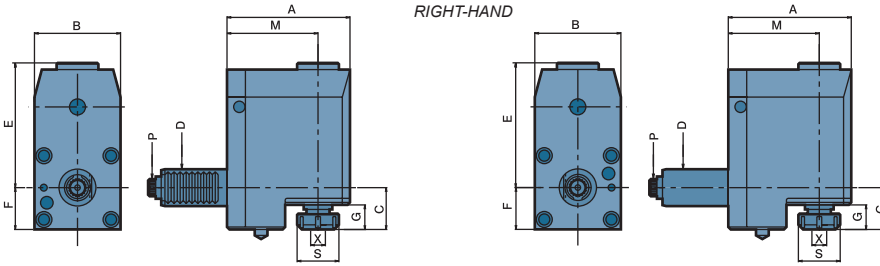

- To be used for collet DIN 6499
- Collet is not included
- External coolant supply

DIMENSIONS

ORDER NO.	D DIN 69880	X Capacity	S	Maximum R.P.M.	i	A	B	C	E	F	G	M	P DIN 5480	CODE NO.
BR3054802572 BL3054802572	30	1-16 ER25	42	5000	1 : 1	95	60	41.5	75.5	31.5	28.5	72	W16X0.8	5006-044A
BR4054803290 BL4054803290	40	2-20 ER32	50	5000	1 : 1	124	80	44	110	42	34	90	W20X0.8	5006-045
BR5054804090 BL5054804090	50	3-26 ER40	63	5000	1 : 1	129	86	49	112	42	39	90	W24X1.25	5006-045A

Radial Tapping Heads-Set Back

DIN 5480

DIMENSIONS

ORDER NO.	D DIN 69880	X Capacity	S	Maximum R.P.M.	i	A	B	C	E	F	G	M	P DIN 5480	CODE NO.
TBR3054801672 TBL3054801672	30	1-10 ER16	30	3000	1 : 1	95	60	44	75.5	31.5	32	72	W16X0.8	5006-046A
TBR4054802090 TBL4054802090	40	1-13 ER20	35	3000	1 : 1	124	80	59.5	110	42	49.5	90	W20X0.8	5006-047



Radial Drilling And Milling Heads

DIN 5480

MODE: FL
LEFT-HAND

MODE: FR
RIGHT-HAND

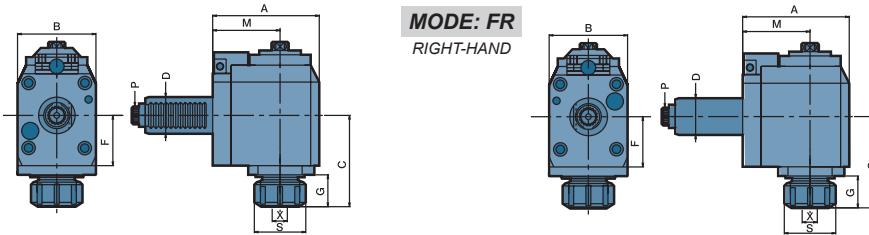

- To be used for collet DIN 6499
- Collet is not included
- External coolant supply

DIMENSIONS

ORDER NO.	D DIN 69880	X Capacity	S	Maximum R.P.M.	i	A	B	C	F	G	M	P DIN 5480	CODE NO.
FR3054802555 FL3054802555	30	1-16 ER25	42	5000	1 : 1	97	64	74.5	41	26	55	W16X0.8	5006-048
FR3054802585 FL3054802585	30	1-16 ER25	42	5000	1 : 1	117	64	74.5	41	26	85	W16X0.8	5006-049
FR4054803265 FL4054803265	40	2-20 ER32	50	5000	1 : 1	99	80	71	40	23	65	W20X0.8	5006-050
FR4054803285 FL4054803285	40	2-20 ER32	50	5000	1 : 1	119	80	71	40	23	85	W20X0.8	5006-051
FR40548032100 FL40548032100	40	2-20 ER32	50	5000	1 : 1	134	80	71	40	23	100	W20X0.8	5006-052

Radial Tapping Heads

DIMENSIONS

ORDER NO.	D DIN 69880	X Capacity	S	Maximum R.P.M.	i	A	B	C	F	G	M	P DIN 5480	CODE NO.
TFR3054801655 TFL3054801655	30	1-10 ER16	30	3000	1 : 1	97	64	75	41	30	55	W16X0.8	5006-053A
TFR3054801685 TFL3054801685	30	1-10 ER16	30	3000	1 : 1	117	64	75	41	30	85	W16X0.8	5006-054
TFR4054802065 TFL4054802065	40	1-13 ER20	35	3000	1 : 1	99	80	70	40	25	65	W20X0.8	5006-055
TFR4054802085 TFL4054802085	40	1-13 ER20	35	3000	1 : 1	119	80	70	40	25	85	W20X0.8	5006-056



Axial Drilling And Milling Heads-Offset



OFFSET

※ ORDER MADE, NOT REFUNDABLE.

DIN 5480

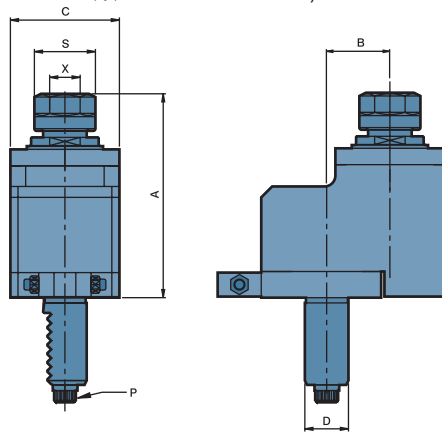

- Collet is not included
- To be used for collet DIN 6499
- External coolant supply

DIMENSIONS

ORDER NO.	D DIN 69880	X Capacity	S	Maximum R.P.M.	i	A	B	C	P DIN 5480	CODE NO.
DA3054802529	30	1-16 ER25	42	4000	1 : 1	100	29	60	W16X0.8	5006-057
DA3054802529/1	※ 30	1-16 ER25	42	8000	1 : 2	100	29	60	W16X0.8	5006-058
DA4054803250	40	2-20 ER32	50	4000	1 : 1	125	65	86	W20X0.8	5006-059



Radial Drilling And Milling Heads

DISK CUTTER UNITS

DIN 5480

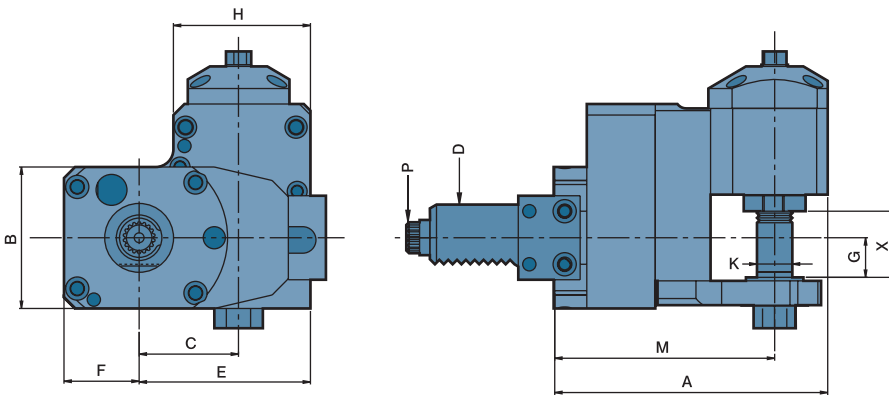

- External coolant supply

DIMENSIONS

ORDER NO.	D DIN 69880	X Capacity	Maximum R.P.M.	i	A	B	C	E	F	G	H	K	M	P DIN 5480	CODE NO.
BR30548016C/3 BL30548016C/3	30	16	3000	3 : 1	133	64	45	77.5	49	5	65	16	108.5	W16X0.8	5006-060



Angular Heads

ANGLE IS ADJUSTED

DIN 5480

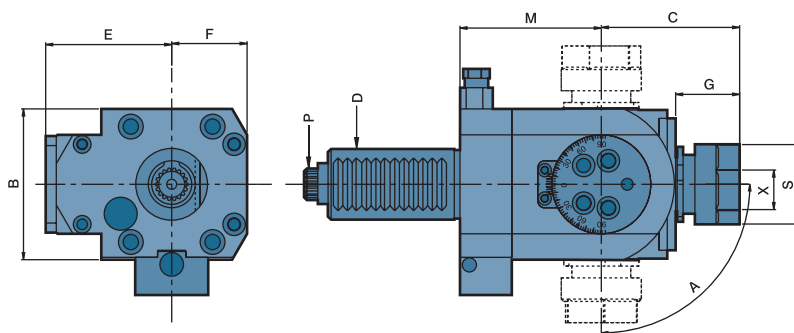

- Collet is not included
- To be used for collet DIN 6499
- External coolant supply

DIMENSIONS

ORDER NO.	D DIN 69880	X Capacity	S	Maximum R.P.M.	i	A	B	C	E	F	G	M	P DIN 5480	CODE NO.
DA30548020B	30	1-13 ER20	35	4000	1 : 1	±90°	64	59	54	32	27	67	W16X0.8	5006-061A



Radial Double Drilling And Milling Heads



VERTEX®

✂ ORDER MADE, NOT REFUNDABLE.

DIN 5480

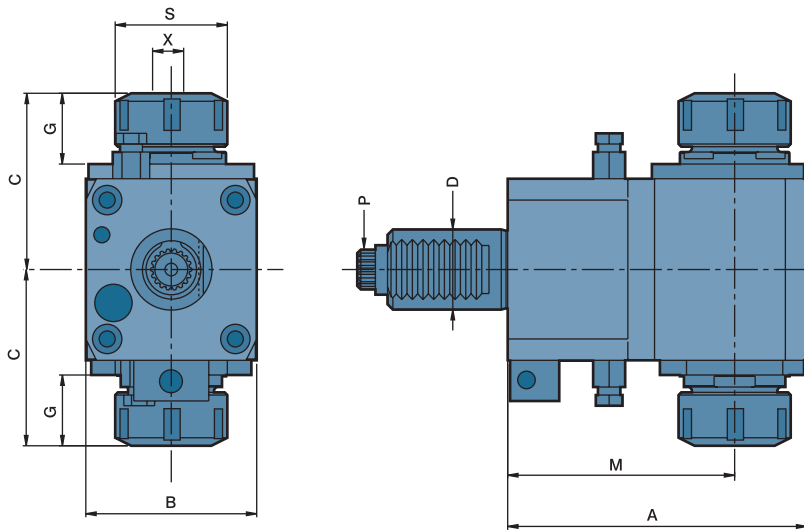

- Collet is not included
- External coolant supply
- To be used for collet DIN 6499

DIMENSIONS

ORDER NO.	D DIN 69880	X Capacity	S	Maximum R.P.M.	i	A	B	C	G	M	P DIN 5480	CODE NO.
DF3054802585D	30	1-16 ER25	42	4000	1 : 1	112	64	66	26.5	85	W16X0.8	5006-062
DF4054803285D	40	2-20 ER32	50	4000	1 : 1	119	80	82	28	85	W20X0.8	5006-063
DF40548032100D	40	2-20 ER32	50	4000	1 : 1	134	80	82	28	100	W20X0.8	5006-064



Axial Double Drilling And Milling Heads

DOUBLE COLLETS, Y OFFSET

DIN 5480

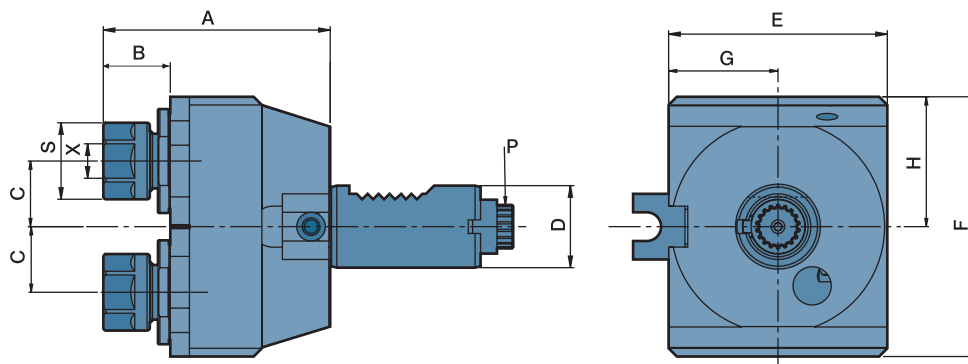

- Collet is not included
- External coolant supply
- To be used for collet DIN 6499

DIMENSIONS

ORDER NO.	D DIN 69880	X Capacity	S	Maximum R.P.M.	i	A	B	C	E	F	G	H	P DIN 5480	CODE NO.
DA30548016DY	30	1-10 ER16	30	4000	1 : 1	83	24.5	24	80	95	40	48	W16X0.8	5006-065



Axial Drilling And Milling Heads



FOR DIN 5482 MACHINE USING

DIN 5482

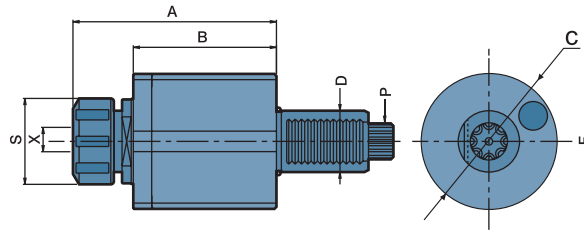
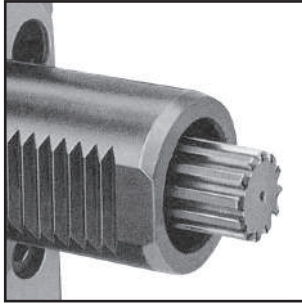

Power Transmission According To DIN 5482

- External coolant supply
- To be used for collet DIN 6499
- Collet is not included

DIMENSIONS

ORDER NO.	D DIN 69880	X Capacity	S	Maximum R.P.M.	i	A	B	C	P DIN 5482	CODE NO.
DA30548225	30	1-16 ER25	42	6000	1 : 1	101	70	68	B15X12	5006-066
DA40548232	40	2-20 ER32	50	6000	1 : 1	110	73.5	86	B17X14	5006-067
DA50548240	50	3-26 ER40	63	6000	1 : 1	120	81.5	96	B20X17	5006-068
DA60548250	60	10-34 ER50	78	6000	1 : 1	140	88.5	116	B25X22	5006-069

Axial Tapping Heads

DIN 5482

DIMENSIONS

ORDER NO.	D DIN 69880	X Capacity	S	Maximum R.P.M.	i	A	B	C	P DIN 5482	CODE NO.
TDA30548216	30	1-10 ER16	30	3000	1 : 1	108	71.5	68	B15X12	5006-070
TDA40548220	40	1-13 ER20	35	3000	1 : 1	95.5	55	86	B17X14	5006-071
TDA50548225	50	1-16 ER25	42	3000	1 : 1	123	81.5	96	B20X17	5006-072
TDA60548232	60	2-20 ER32	50	3000	1 : 1	158.5	88.5	116	B25X22	5006-073



Axial Milling Heads

※ ORDER MADE, NOT REFUNDABLE.

DIN 5480

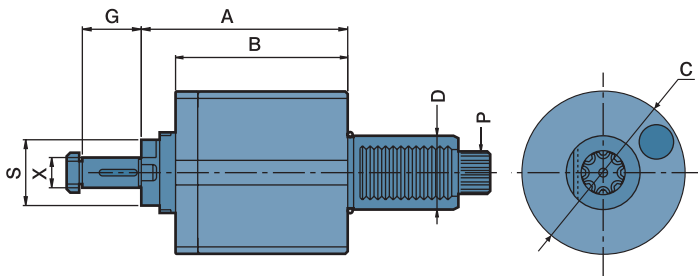

- External coolant and intermediate rings supply
- To be used for cutter arbor according to DIN 6358

DIMENSIONS

ORDER NO.	D DIN 69880	X Capacity	S	Maximum R.P.M.	i	A	B	C	G	P DIN 5482	CODE NO.
DA30548216C	30	16	32	3000	1 : 1	91.5	70	68	27	B15X12	5006-074
DA40548216C	40	16	32	3000	1 : 1	68.5	55	86	27	B17X14	5006-075
DA40548222C	40	22	32	3000	1 : 1	68.5	55	86	31	B17X14	5006-076
DA50548222C	50	22	40	3000	1 : 1	117	81.5	96	31	B20X17	5006-077
DA50548227C	50	27	40	3000	1 : 1	117	88.5	96	33	B20X17	5006-078



Radial Drilling And Milling Heads



BACKWARDS

DIN 5482

MODE: BL
LEFT-HAND

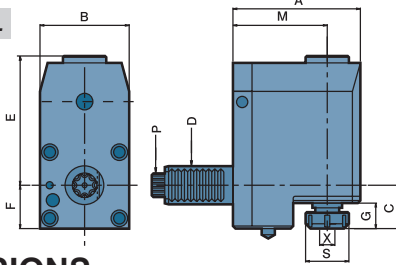

MODE: BR
RIGHT-HAND

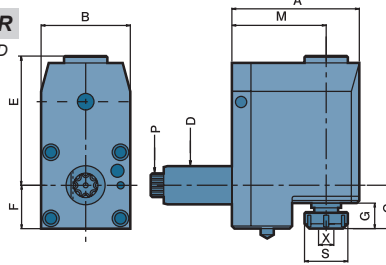

- To be used for collet DIN 6499
- Collet is not included
- External coolant supply

DIMENSIONS

ORDER NO.	D DIN 69880	X Capacity	S	Maximum R.P.M.	i	A	B	C	E	F	G	M	P DIN 5482	CODE NO.
BR3054822572 BL3054822572	30	1-16 ER25	42	5000	1 : 1	95	60	42	75.5	31.5	28.5	72	B15X12	5006-079A
BR4054823290 BL4054823290	40	2-20 ER32	50	5000	1 : 1	124	80	44	110	42	34	90	B17X14	5006-080
BR5054824090 BL5054824090	50	3-26 ER40	63	5000	1 : 1	129	86	49	112	45	39	90	B20X17	5006-081
BR60548250106 BL60548250106	60	10-34 ER50	78	5000	1 : 1	147	104	83	118	54	42	106	B25X22	5006-082A

Radial Tapping Heads-Backwards

DIMENSIONS

ORDER NO.	D DIN 69880	X Capacity	S	Maximum R.P.M.	i	A	B	C	E	F	G	M	P DIN 5482	CODE NO.
TBR3054821672 TBL3054821672	30	1-10 ER16	30	3000	1 : 1	95	60	44	75.5	31.5	32	69	B15X12	5006-083A
TBR4054822090 TBL4054822090	40	1-13 ER20	35	3000	1 : 1	24	80	50	110	42	34	90	B17X14	5006-084
TBR5054822590 TBL5054822590	50	2-16 ER25	42	3000	1 : 1	129	86	54	112	45	36	90	B20X17	5006-085
TBR60548232106 TBL60548232106	60	2-20 ER32	50	3000	1 : 1	147	104	87	118	54	40	106	B25X22	5006-086A



Radial Drilling And Milling Heads

✂ ORDER MADE, NOT REFUNDABLE.

DIN 5482

MODE: FL
LEFT-HAND

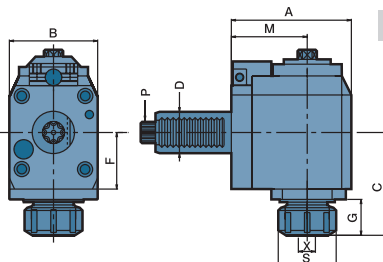

MODE: FR
RIGHT-HAND

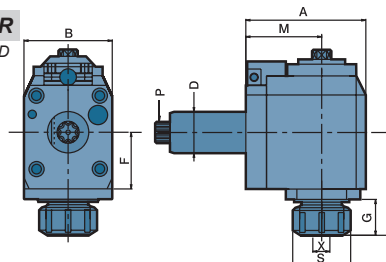

- To be used for collet DIN 6499
- Collet is not included
- External coolant supply

DIMENSIONS

ORDER NO.	D DIN 69880	X Capacity	S	Maximum R.P.M.	i	A	B	C	F	G	M	P DIN 5482	CODE NO.
FR3054822565 FL3054822565	30	1-16 ER25	42	5000	1 : 1	97	64	74.5	41	26	65	B15X12	5006-087
FR3054822585 FL3054822585	30	1-16 ER25	42	5000	1 : 1	117	64	74.5	41	26	85	B15X12	5006-088
FR4054823265 FL4054823265	40	2-20 ER32	50	5000	1 : 1	99	80	71	40	23	65	B17X14	5006-089
FR4054823285 FL4054823285	40	2-20 ER32	50	5000	1 : 1	119	80	71	40	23	85	B17X14	5006-090

Radial Tapping Heads

DIMENSIONS

ORDER NO.	D DIN 69880	X Capacity	S	Maximum R.P.M.	i	A	B	C	F	G	M	P DIN 5482	CODE NO.
TFR3054821665 TFL3054821665	30	1-10 ER16	30	3000	1 : 1	97	64	75	41	30	65	B15X12	5006-092
TFR3054821685 TFL3054821685	30	1-10 ER16	30	3000	1 : 1	117	64	75	41	30	85	B15X12	5006-093
TFR4054822065 TFL4054822065	40	1-13 ER20	35	3000	1 : 1	99	80	70	40	25	65	B17X14	5006-094
TFR4054822085 TFL4054822085	40	1-13 ER20	35	3000	1 : 1	119	80	70	40	25	85	B17X14	5006-095



Axial Drilling And Milling Heads



OFFSET TYPE ※ ORDER MADE, NOT REFUNDABLE. DIN 5482

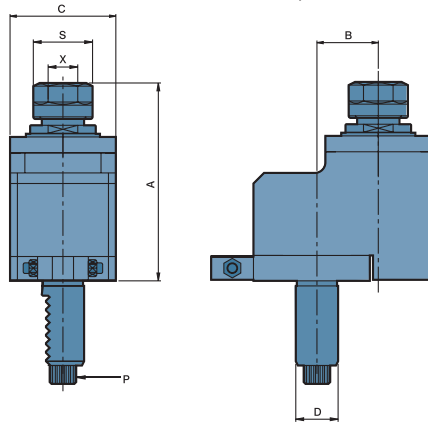

- To be used for collet DIN 6499
- Collet is not included
- External coolant supply

DIMENSIONS

ORDER NO.	D DIN 69880	X Capacity	S	Maximum R.P.M.	i	A	B	C	P DIN 5482	CODE NO.
DA3054822529	30	1-16 ER25	42	4000	1 : 1	100	29	60	B15X12	5006-097
DA3054822529/1	※ 30	1-16 ER25	42	8000	1 : 2	100	29	60	B15X12	5006-098
DA4054823250	40	2-20 ER32	50	4000	1 : 1	125	50	75	B17X14	5006-099
DA5054824065	50	3-26 ER40	63	3000	1 : 1	124	65	86	B20X17	5006-100



Radial Milling Heads

DISK CUTTER UNITS

DIN 5482

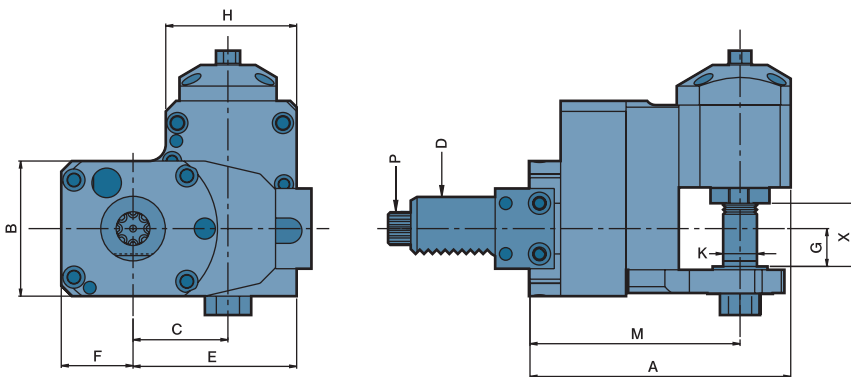

- External coolant supply

DIMENSIONS

ORDER NO.	D DIN 69880	X Capacity	Maximum R.P.M.	i	A	B	C	E	F	G	H	K	M	P DIN 5482	CODE NO.
BR30548216C/3 BL30548216C/3	30	16	3000	3 : 1	133	64	45	77.5	49	5	65	16	107.5	B15X12	5006-101



Angular Heads

DIN 5482

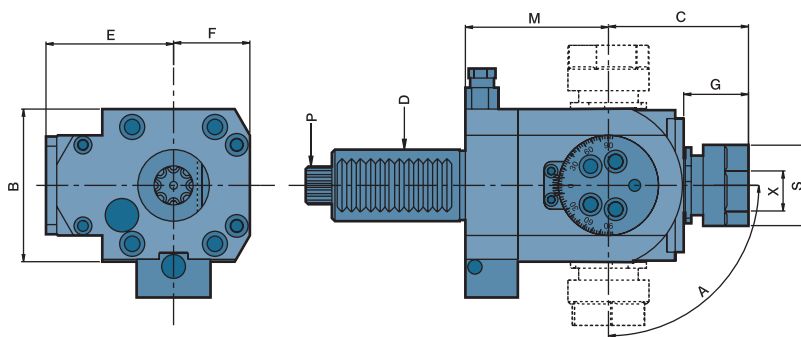

- To be used for collet DIN 6499
- Collet is not included
- External coolant supply

DIMENSIONS

ORDER NO.	D DIN 69880	X Capacity	S	Maximum R.P.M.	i	A	B	C	E	F	G	M	P DIN 5482	CODE NO.
DA30548220B	30	1-13 ER20	35	4000	1 : 1	±90°	64	59	54	32	27	67	B15X12	5006-102A



Axial Drilling And Milling Heads-



For "Baruffaldi" Type

SPUR COUPLING-MT TYPE

※ ORDER MADE, NOT REFUNDABLE.

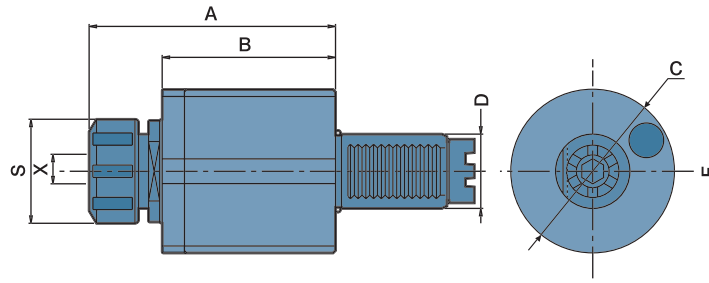
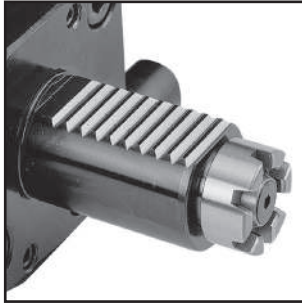

- Power Transmission According To "BARUFFALDI"
- MT: Frontal Transmission Coupling Gear is Fixed Version

- To be used for collet DIN 6499
- External coolant supply
- Collet is not included

DIMENSIONS

ORDER NO.	D DIN 69880	X Capacity	S	Maximum R.P.M.	i	A	B	C	CODE NO.
DA20MT16	20	1-10 ER16	30	6000	1 : 1	76	48	58	5006-103
DA30MT25	30	1-16 ER25	42	6000	1 : 1	86	55	68	5006-104
DA40MT32	40	2-20 ER32	50	6000	1 : 1	112	55	86	5006-105
DA50MT40	50	3-26 ER40	63	6000	1 : 1	118	81.5	96	5006-106

Axial Tapping Heads

DIMENSIONS

ORDER NO.	D DIN 69880	X Capacity	S	Maximum R.P.M.	i	A	B	C	CODE NO.
TDA30MT16	30	1-10 ER16	30	3000	1 : 1	108	71.5	68	5006-107
TDA40MT20	40	1-13 ER20	35	3000	1 : 1	95.5	55	86	5006-108
TDA50MT25	50	1-16 ER25	42	3000	1 : 1	123	81.5	96	5006-109



Axial Milling Heads

SPUR COUPLING-MT TYPE

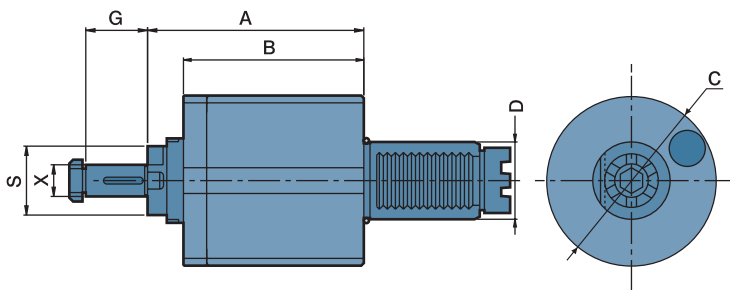

- External coolant and intermediate rings supply
- To be used for cutter arbor according to DIN 6358

DIMENSIONS

ORDER NO.	D DIN 69880	X Capacity	S	Maximum R.P.M.	i	A	B	C	G	CODE NO.
DA30MT16C	30	16	32	3000	1 : 1	91.5	55	68	27	5006-110
DA40MT16C	40	16	32	3000	1 : 1	68.5	55	86	27	5006-111
DA40MT22C	40	22	32	3000	1 : 1	68.5	55	86	31	5006-112
DA50MT22C	50	22	40	3000	1 : 1	117	81.5	96	31	5006-113
DA50MT27C	50	27	40	3000	1 : 1	117	81.5	96	33	5006-114



Radial Drilling And Milling Heads-Backwards



✂ ORDER MADE, NOT REFUNDABLE. SPUR COUPLING-MT TYPE

MODE: BL
LEFT-HAND

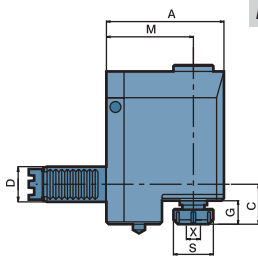
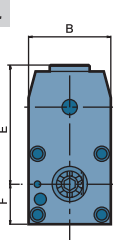

MODE: BR
RIGHT-HAND

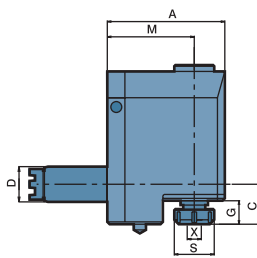
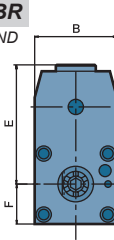

- External coolant supply
- To be used for collet DIN 6499
- Collet is not included

DIMENSIONS

ORDER NO.	D DIN 69880	X Capacity	S	Maximum R.P.M.	i	A	B	C	E	F	G	M	CODE NO.
BR20MT1660 BL20MT1660	20	1-10 ER16	30	5000	1 : 1	83	50	35	70	27	27	60	5006-115A
BR30MT2572 BL30MT2572	30	1-16 ER25	42	5000	1 : 1	95	60	42	76	32	29	72	5006-116A
BR40MT3290 BL40MT3290	40	2-20 ER32	50	5000	1 : 1	124	80	44	110	42	34	90	5006-117
BR50MT4090 BL50MT4090	50	3-26 ER40	63	5000	1 : 1	129	86	49	112	45	39	90	5006-118

Radial Tapping Heads-Backwards

DIMENSIONS

ORDER NO.	D DIN 69880	X Capacity	S	Maximum R.P.M.	i	A	B	C	E	F	G	M	CODE NO.
TBR30MT1672 TBL30MT1672	30	1-10 ER16	30	3000	1 : 1	95	60	44	76	32	32	72	5006-119A
TBR40MT2090 TBL40MT2090	40	1-13 ER20	35	3000	1 : 1	124	80	50	110	42	34	90	5006-120
TBR50MT2590 TBL50MT2590	50	1-16 ER25	42	3000	1 : 1	129	86	54	112	45	36	90	5006-121



Radial Drilling And Milling Heads

SPUR COUPLING-MT TYPE

MODE: FL
LEFT-HAND

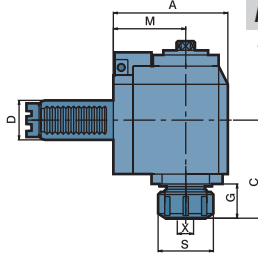
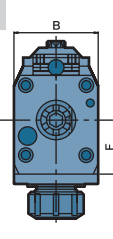

MODE: FR
RIGHT-HAND

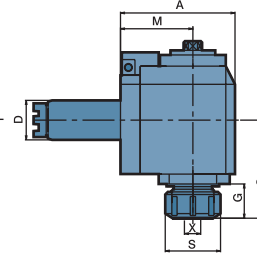
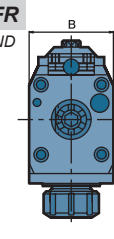

- External coolant supply
- To be used for collet DIN 6499
- Collet is not included

DIMENSIONS

ORDER NO.	D DIN 69880	X Capacity	S	Maximum R.P.M.	i	A	B	C	F	G	M	CODE NO.
FR30MT2565 FL30MT2565	30	1-16 ER25	42	5000	1 : 1	97	64	74.5	41	26	65	5006-122
FR30MT2585 FL30MT2585	30	1-16 ER25	42	5000	1 : 1	117	64	74.5	41	26	85	5006-123
FR40MT3265 FL40MT3265	40	2-20 ER32	50	5000	1 : 1	99	80	71	40	23	65	5006-124
FR40MT3285 FL40MT3285	40	2-20 ER32	50	5000	1 : 1	119	80	71	40	23	85	5006-125
FR40MT32100 FL40MT32100	40	2-20 ER32	50	5000	1 : 1	134	80	71	40	23	100	5006-126

Radial Tapping Heads

DIMENSIONS

ORDER NO.	D DIN 69880	X Capacity	S	Maximum R.P.M.	i	A	B	C	F	G	M	CODE NO.
TFR30MT1665 TFL30MT1665	30	1-10 ER16	30	3000	1 : 1	97	64	75	41	30	65	5006-128
TFR30MT1685 TFL30MT1685	30	1-10 ER16	30	3000	1 : 1	117	64	75	41	30	85	5006-129
TFR40MT2065 TFL40MT2065	40	1-13 ER20	35	3000	1 : 1	99	80	70	40	25	65	5006-130
TFR40MT2085 TFL40MT2085	40	1-13 ER20	35	3000	1 : 1	119	80	70	40	25	85	5006-131
TFR50MT2575 TFL50MT2575	50	1-16 ER25	42	3000	1 : 1	115	88	103	56	42	75	5006-132



Axial Drilling And Milling Heads



OFFSET TYPE

SPUR COUPLING-MT TYPE

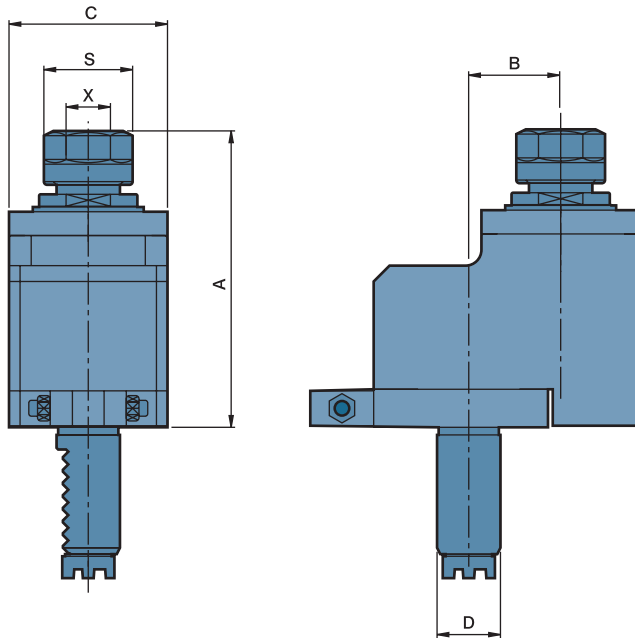

- Collet is not included
- External coolant supply
- To be used for collet DIN 6499

DIMENSIONS

ORDER NO.	D DIN 69880	X Capacity	S	Maximum R.P.M.	i	A	B	C	CODE NO.
DA20MT1629	20	1-10 ER16	30	4000	1 : 1	93.5	29	50	5006-133
DA30MT2529	30	1-16 ER25	42	4000	1 : 1	100	29	60	5006-134
DA30MT2529/1	※ 30	2-20 ER32	42	8000	1 : 2	100	29	60	5006-135
DA40MT3250	40	2-20 ER32	50	4000	1 : 1	125	50	75	5006-136
DA50MT4065	50	3-26 ER40	63	3000	1 : 1	124	65	86	5006-137



Radial Milling Heads

※ ORDER MADE, NOT REFUNDABLE

SPUR COUPLING-MT TYPE

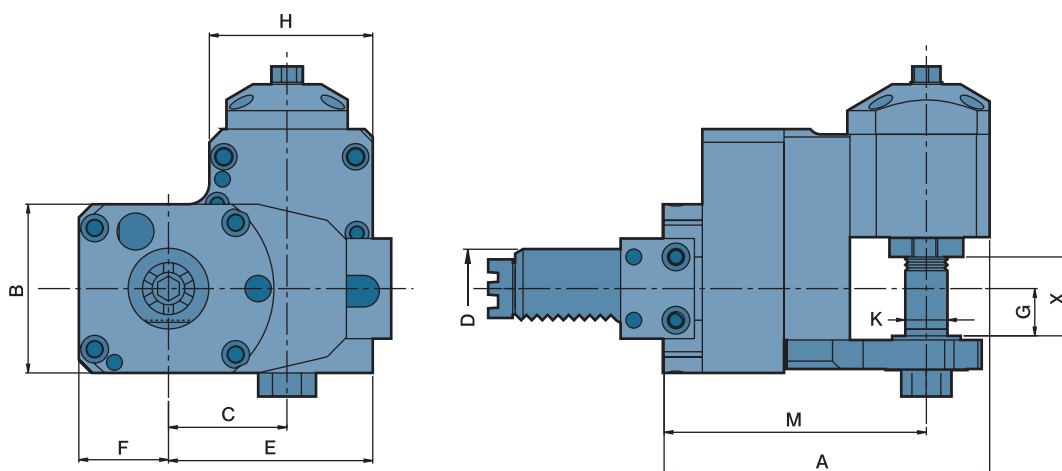

- External coolant supply

DIMENSIONS

ORDER NO.	D DIN 69880	X Capacity	Maximum R.P.M.	i	A	B	C	E	F	G	H	K	M	CODE NO.
BR30MT16C/3 BL30MT16C/3	30	16	3000	3 : 1	133	64	45	77.5	49	5	65	16	107.5	5006-138

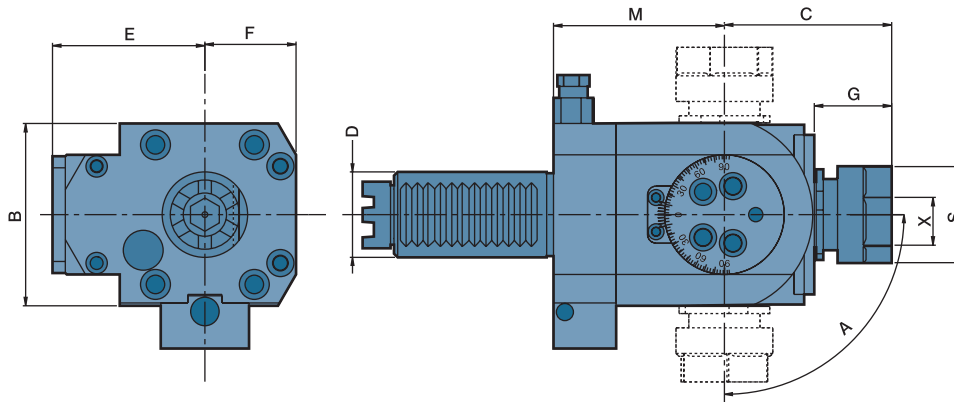

- To be used for collet DIN 6499
- External coolant supply
- Collet is not included

DIMENSIONS

ORDER NO.	D DIN 69880	X Capacity	S	Maximum R.P.M.	i	A	B	C	E	F	G	M	CODE NO.
DA30MT20B	30	1-13 ER20	35	4000	1 : 1	±90°	64	59	54	32	27	67	5006-139A



Radial Drilling And Milling Heads

DOUBLE HEAD TYPE

SPUR COUPLING-MT TYPE

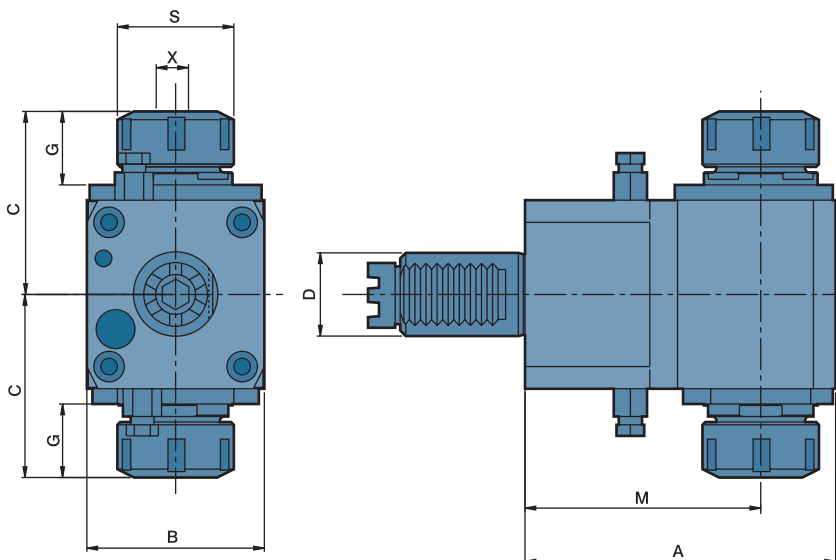

- To be used for collet DIN 6499
- External coolant supply
- Collet is not included

DIMENSIONS

ORDER NO.	D DIN 69880	X Capacity	S	Maximum R.P.M.	i	A	B	C	G	M	CODE NO.
DF30MT2585D	30	1-16 ER25	42	4000	1 : 1	112	64	66	27	85	5006-140
DF40MT3285D	40	2-20 ER32	50	4000	1 : 1	119	80	82	28	85	5006-141
DF40MT32100D	40	2-20 ER32	50	4000	1 : 1	134	80	82	28	100	5006-142



Axial Drilling And Milling Heads-



For "Diplomatic" Type

SPUR COUPLING-IT TYPE

※ ORDER MADE, NOT REFUNDABLE.

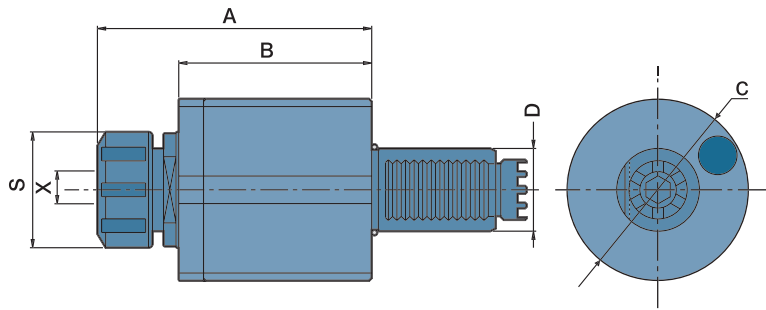
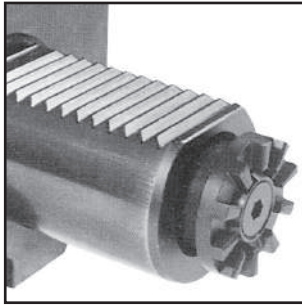

- Power Transmission According To "DIPLOMATIC"
- IT: Fron-side Coupling is Elastic Stroke

- External coolant supply
- To be used for collet DIN 6499
- Collet is not included

DIMENSIONS

ORDER NO.	D DIN 69880	X Capacity	S	Maximum R.P.M.	i	A	B	C	CODE NO.
DA30IT25	30	1-16 ER25	42	6000	1 : 1	86	55	68	5006-143

Axial Tapping Heads

DIMENSIONS

ORDER NO.	D DIN 69880	X Capacity	S	Maximum R.P.M.	i	A	B	C	CODE NO.
TDA30IT16	30	1-10 ER16	30	3000	1 : 1	85	55	68	5006-146
TDA40IT20	40	1-13 ER20	35	3000	1 : 1	102	55	86	5006-147



Axial Milling Heads

SPUR COUPLING-IT TYPE

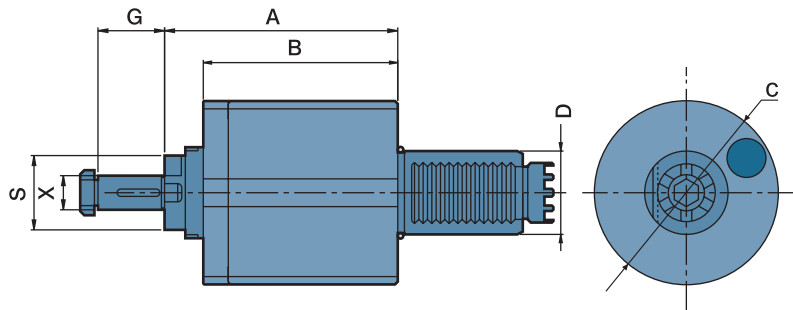

- To be used for cutter arbor according to DIN 6358
- External coolant and intermediate rings supply

DIMENSIONS

ORDER NO.	D DIN 69880	X DIN 6358	S	Maximum R.P.M.	i	A	B	C	G	CODE NO.
DA30IT16C	30	16	32	3000	1 : 1	91.5	55	68	27	5006-149
DA40IT16C	40	16	32	3000	1 : 1	68.5	55	86	27	5006-150
DA40IT22C	40	22	32	3000	1 : 1	68.5	55	86	31	5006-151



Radial Drilling And Milling Heads



✘ ORDER MADE, NOT REFUNDABLE.

SPUR COUPLING-IT TYPE

MODE: FL
LEFT-HAND

MODE: FR
RIGHT-HAND

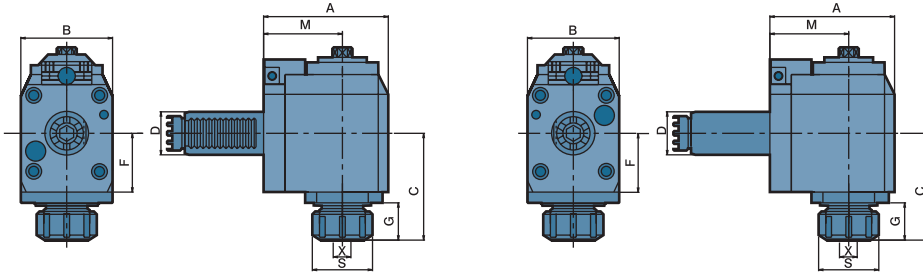

- External coolant supply
- To be used for collet DIN 6499
- Collet is not included

DIMENSIONS

ORDER NO.	D DIN 69880	X Capacity	S	Maximum R.P.M.	i	A	B	C	F	G	M	CODE NO.
FL30IT2565	30	1-16 ER25	42	5000	1 : 1	97	64	74.5	41	26	65	5006-154
FR30IT2585 FL30IT2585	30	1-16 ER25	42	5000	1 : 1	117	64	74.5	41	26	85	5006-155
FL40IT3265	40	2-20 ER32	50	5000	1 : 1	99	80	71	40	23	65	5006-156
FL40IT32100	40	2-20 ER32	50	5000	1 : 1	134	80	71	40	23	100	5006-158



Radial Tapping Heads

DIMENSIONS

ORDER NO.	D DIN 69880	X Capacity	S	Maximum R.P.M.	i	A	B	C	F	G	M	CODE NO.
TFR30IT1665 TFL30IT1665	30	1-10 ER16	32	3000	1 : 1	97	64	75	41	30	65	5006-160
TFR30IT1685 TFL30IT1685	30	1-10 ER16	32	3000	1 : 1	117	64	75	41	30	85	5006-161
TFR40IT2065	40	1-13 ER20	35	3000	1 : 1	99	80	70	40	25	65	5006-162
TFR40IT2085 TFL40IT2085	40	1-13 ER20	35	3000	1 : 1	119	80	70	40	25	85	5006-163



Angular Heads

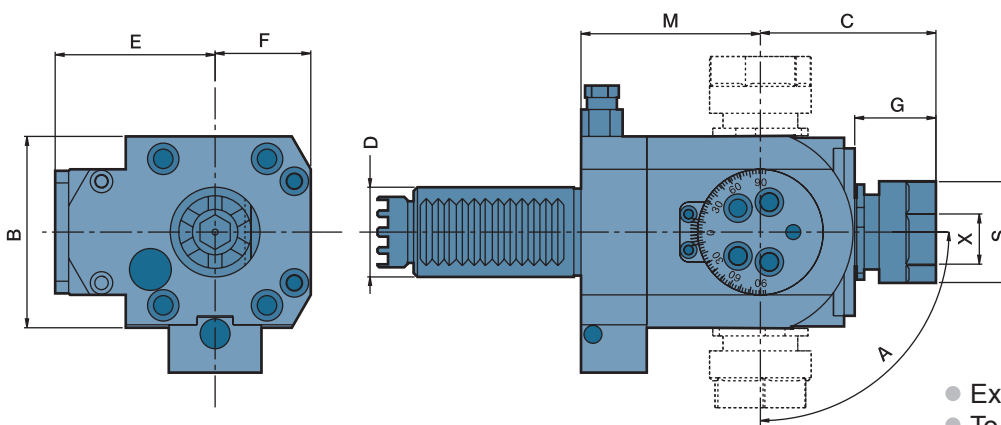

- External coolant supply
- To be used for collet DIN 6499
- Collet is not included

DIMENSIONS

ORDER NO.	D DIN 69880	X Capacity	S	Maximum R.P.M.	i	A	B	C	E	F	G	M	CODE NO.
DA30IT20B	30	1-13 ER20	35	4000	1 : 1	±90°	64	59	54	32	27	67	5006-165A

Other shank dimensions under development



Radial Drilling And Milling Heads



VERTEX®

DOUBLE COLLETS

SPUR COUPLING-IT TYPE

※ ORDER MADE, NOT REFUNDABLE.

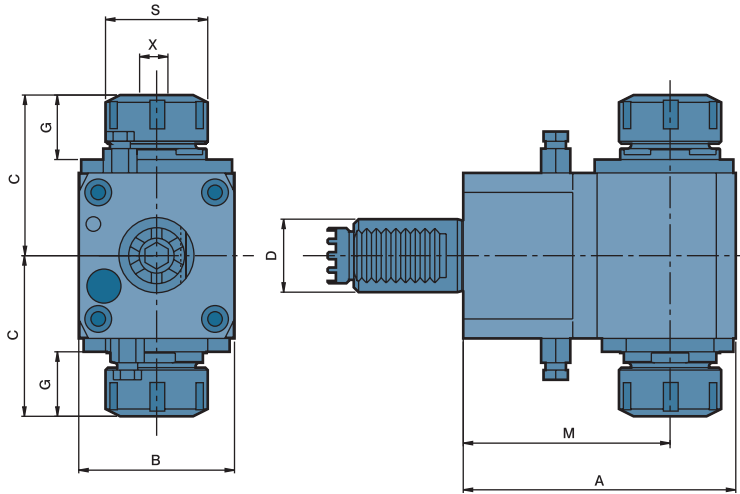

- Collet is not included
- External coolant supply
- To be used for collet DIN 6499

DIMENSIONS

ORDER NO.	D DIN 69880	X Capacity	S	Maximum R.P.M.	i	A	B	C	G	M	CODE NO.
DF30IT2585D	30	1-16 ER25	42	4000	1 : 1	112	64	66	26.5	85	5006-166
DF40IT3285D	40	2-20 ER32	50	4000	1 : 1	119	80	82	28	85	5006-167
DF40IT32100D	40	2-20 ER32	50	4000	1 : 1	134	80	82	28	100	5006-168

Other shank dimensions under development



VDI Dimensional Specification of Shank DIN 69880

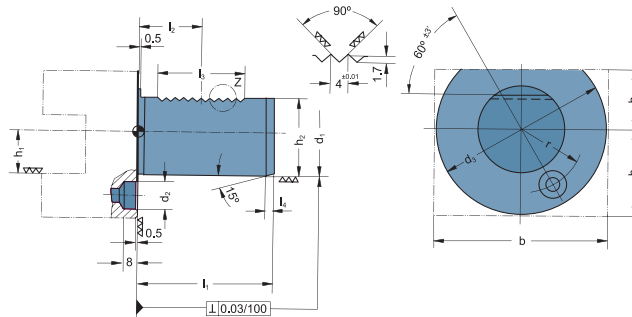

DIMENSIONS

d1 h6	l1 ±0.3	d2		d3	h1 max	h2 ±0.1	l2 ±0.05	l3 min	l4 +1	r4 ±0.02
20	40	10	H6	50	16	18	21.7	24	2	18
30	55	14	H9	68	20	27	29.7	40	2	25
40	63	14	H9	83	25	36	29.7	40	3	32
50	78	16	H9	98	32	45	35.7	48	3	37
60	94	16	H9	123	32	55	43.7	56	4	48

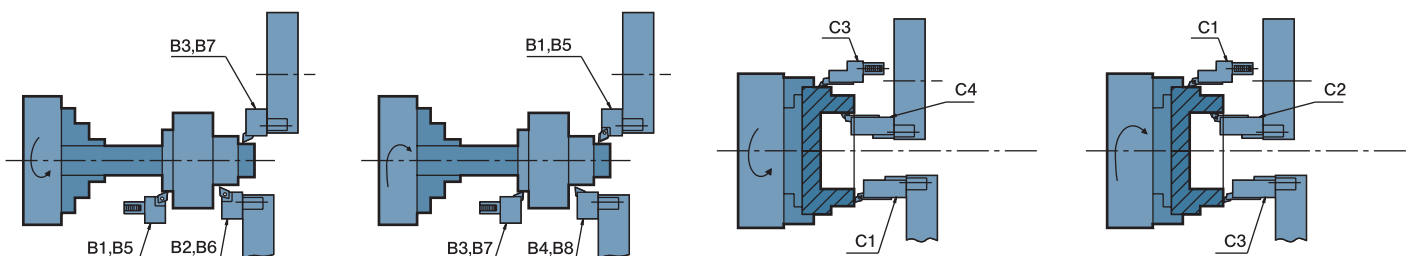



Radial Static Holders



B1 B2 TYPE

✗ ORDER MADE, NOT REFUNDABLE.

DIN 69880

B1

- Short
- External Coolant Supply
- Right-hand

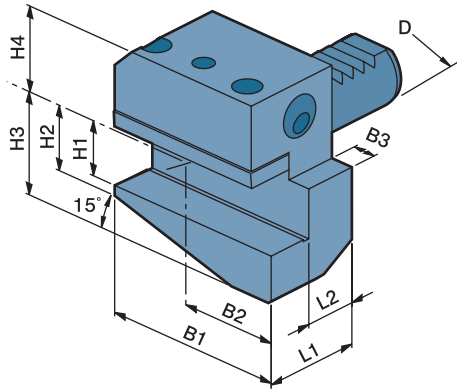

DIMENSIONS

ORDER NO.	D	B1	B2	B3	H1	H2	H3	H4	L1	L2	CODE NO.
B1-20x16	20	55	30	7	16	19	30	25	30	16	5006-180
B1-30x20	30	70	35	10	20	26	38	28	40	22	5006-181
B1-40x25	40	85	42.5	12.5	25	35	48	32.5	44	22	5006-182
B1-50x32	50	100	50	16	32	42	60	35	55	30	5006-183
B1-60x32	60	125	62.5	16	32	46	62.5	42.5	60	30	5006-184

B2

- Left-hand
- External Coolant Supply
- Short

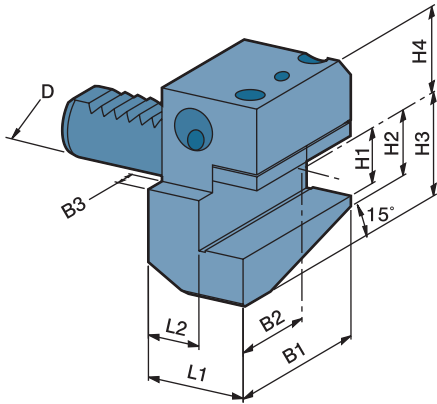

DIMENSIONS

ORDER NO.	D	B1	B2	B3	H1	H2	H3	H4	L1	L2	CODE NO.
B2-20x16	20	55	30	7	16	19	30	25	30	16	5006-185
B2-30x20	30	70	35	10	20	26	38	28	40	22	5006-186
B2-40x25	40	85	42.5	12.5	25	35	48	32.5	44	22	5006-187
B2-50x32	50	100	50	16	32	42	60	35	55	30	5006-188
B2-60x32	60	125	62.5	16	32	46	62.5	42.5	60	30	5006-189



Radial Static Holders

B3 B4 TYPE

DIN 69880

B3

- Short
- External Coolant Supply
- Right-hand

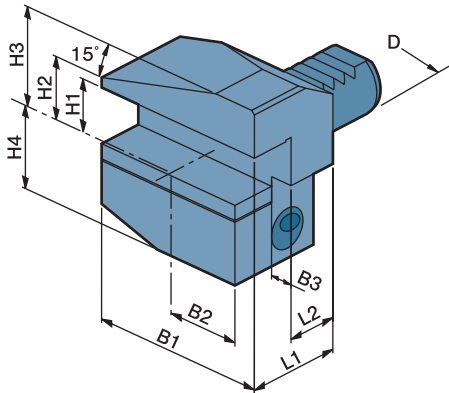

DIMENSIONS

ORDER NO.	D	B1	B2	B3	H1	H2	H3	H4	L1	L2	CODE NO.
B3-20x16	20	55	30	7	16	19	30	25	30	16	5006-190
B3-30x20	30	70	35	10	20	22	38	35	40	22	5006-191
B3-40x25	40	85	42.5	12.5	25	30	48	42.5	44	22	5006-192
B3-50x32	50	100	50	16	32	35	60	50	55	30	5006-193
B3-60x32	60	125	62.5	16	32	42.5	62.5	42.5	60	30	5006-194

B4

- Left-hand
- External Coolant Supply
- Short

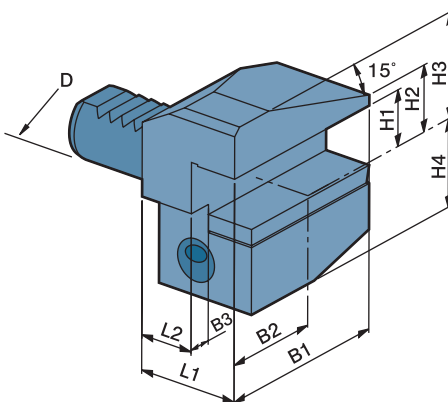

DIMENSIONS

ORDER NO.	D	B1	B2	B3	H1	H2	H3	H4	L1	L2	CODE NO.
B4-20x16	20	55	30	7	16	19	30	25	30	16	5006-195
B4-30x20	30	70	35	10	20	22	38	35	40	22	5006-196
B4-40x25	40	85	42.5	12.5	25	30	48	42.5	44	22	5006-197
B4-50x32	50	100	50	16	32	35	60	50	55	30	5006-198
B4-60x32	60	125	62.5	16	32	42.5	62.5	42.5	60	30	5006-199



Radial Static Holders



B5 B6 TYPE

✳ ORDER MADE, NOT REFUNDABLE.

DIN 69880

B5

- External Coolant Supply
- Right-hand
- Long

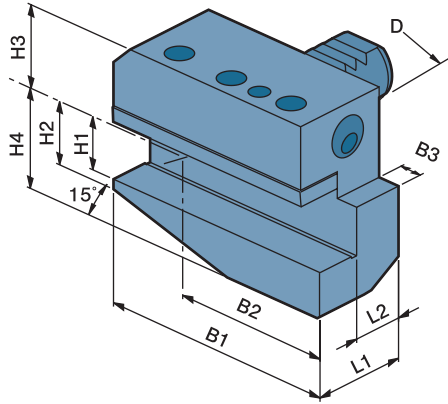

DIMENSIONS

ORDER NO.	D	B1	B2	B3	H1	H2	H3	H4	L1	L2	CODE NO.
B5-20x16	20	75	50	7	16	19	30	25	30	16	5006-200
B5-30x20	30	100	65	10	20	26	38	28	40	22	5006-201
B5-40x25	40	118	76	12.5	25	35	48	32.5	44	22	5006-202
B5-50x32	50	130	80	16	32	42	60	35	55	30	5006-203
B5-60x32	60	145	83	16	32	46	62.5	42.5	60	30	5006-204

B6

- Left-hand
- External Coolant Supply
- Long

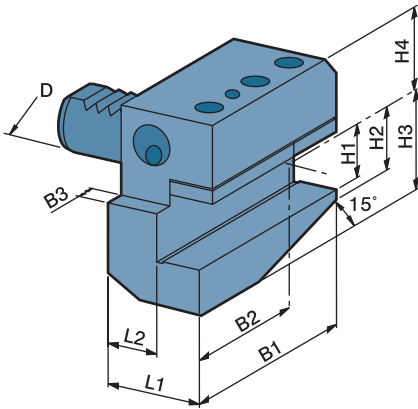

DIMENSIONS

ORDER NO.	D	B1	B2	B3	H1	H2	H3	H4	L1	L2	CODE NO.
B6-20x16	20	75	50	7	16	19	30	25	30	16	5006-205
B6-30x20	30	100	65	10	20	26	38	28	40	22	5006-206
B6-40x25	40	118	76	12.5	25	35	48	32.5	44	22	5006-207
B6-50x32	50	130	80	16	32	42	60	35	55	30	5006-208
B6-60x32	60	145	83	16	32	46	62.5	42.5	60	30	5006-209



Radial Static Holders

B7 B8 TYPE

DIN 69880

B7

- External Coolant Supply
- Right-hand
- Long

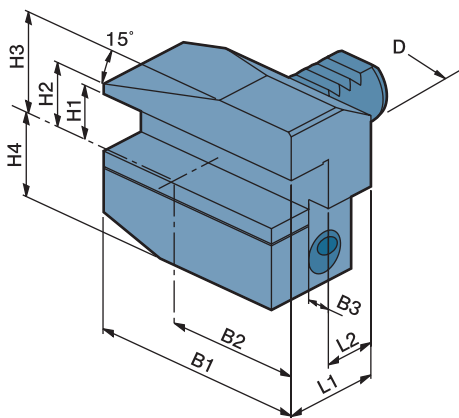

DIMENSIONS

ORDER NO.	D	B1	B2	B3	H1	H2	H3	H4	L1	L2	CODE NO.
B7-20x16	20	75	50	7	16	19	30	25	30	16	5006-210
B7-30x20	30	100	65	10	20	22	38	35	40	22	5006-211
B7-40x25	40	118	75.5	12.5	25	30	48	42.5	44	22	5006-212
B7-50x32	50	130	80	16	32	35	60	50	55	30	5006-213
B7-60x32	60	145	82.5	16	32	42.5	62.5	42.5	60	30	5006-214

B8

- Left-hand
- External Coolant Supply
- Long

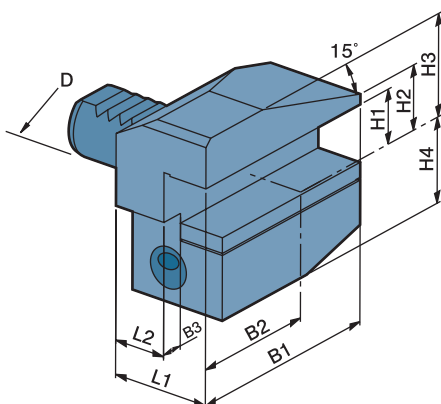

DIMENSIONS

ORDER NO.	D	B1	B2	B3	H1	H2	H3	H4	L1	L2	CODE NO.
B8-20x16	20	75	50	7	16	19	30	25	30	16	5006-215
B8-30x20	30	100	65	10	20	22	38	35	40	22	5006-216
B8-40x25	40	118	75.5	12.5	25	30	48	42.5	44	22	5006-217
B8-50x32	50	130	80	16	32	35	60	50	55	30	5006-218
B8-60x32	60	145	82.5	16	32	42.5	62.5	42.5	60	30	5006-219



Axial Static Holders



C1 C2 TYPE

※ ORDER MADE, NOT REFUNDABLE.

DIN 69880

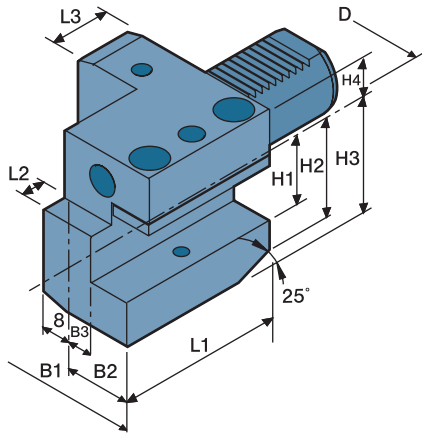

C1

- Right-hand
- External Coolant Supply

DIMENSIONS

ORDER NO.	D	B1	B2	B3	H1	H2	H3	H4	L1	L2	L3	CODE NO.
C1-20x16	20	65	40	26	16	23	30	25	50	7	30	5006-220
C1-30x20	30	70	35	17	20	28	38	28	70	10	30	5006-221
C1-40x25	40	85	42.5	21	25	-	48	32.5	85	12.5	30	5006-222
C1-50x32	50	100	50	26	32	-	60	35	100	16	40	5006-223
C1-60x32	60	125	62.5	33	32	-	62.5	42.5	125	16	40	5006-224

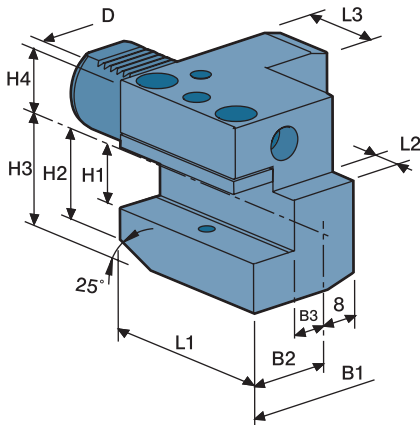

C2

- External Coolant Supply
- Left-hand

DIMENSIONS

ORDER NO.	D	B1	B2	B3	H1	H2	H3	H4	L1	L2	L3	CODE NO.
C2-20x16	20	65	40	26	16	23	30	25	50	7	30	5006-225
C2-30x20	30	76	41	23	20	28	38	28	70	10	30	5006-226
C2-40x25	40	90	47.5	25.5	25	-	48	32.5	85	12.5	30	5006-227
C2-50x32	50	105	55	30.5	32	-	60	35	100	16	40	5006-228
C2-60x32	60	125	62.5	33	32	-	62.5	42.5	125	16	40	5006-229



Axial Static Holders

C3 C4 TYPE

DIN 69880

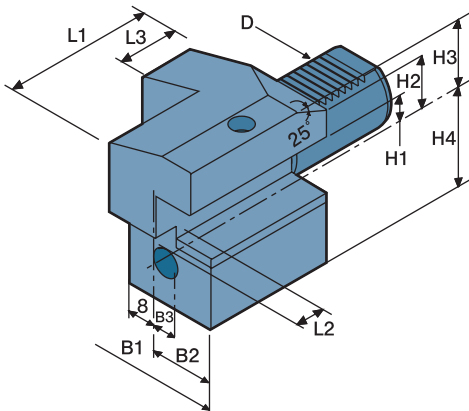

C3

- Right-hand
- External Coolant Supply

DIMENSIONS

ORDER NO.	D	B1	B2	B3	H1	H2	H3	H4	L1	L2	L3	CODE NO.
C3-20x16	20	65	40	26	16	23	30	25	50	7	30	5006-230
C3-30x20	30	70	35	17	20	28	38	35	70	10	30	5006-231
C3-40x25	40	85	42.5	21	25	-	48	42.5	85	12.5	30	5006-232
C3-50x32	50	100	50	26	32	-	60	50	100	16	40	5006-233
C3-60x32	60	125	62.5	33	32	-	62.5	62.5	125	16	40	5006-234

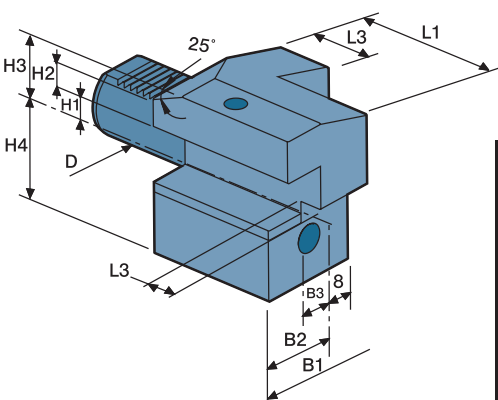

C4

- External Coolant Supply
- Left-hand

DIMENSIONS

ORDER NO.	D	B1	B2	B3	H1	H2	H3	H4	L1	L2	L3	CODE NO.
C4-20x16	20	65	40	26	16	23	30	25	50	7	30	5006-235
C4-30x20	30	76	41	23	20	28	38	35	70	10	30	5006-236
C4-40x25	40	90	47.5	25.5	25	-	48	42.5	85	12.5	30	5006-237
C4-50x32	50	105	55	30.5	32	-	60	50	100	16	40	5006-238
C4-60x32	60	125	62.5	33	32	-	62.5	62.5	125	16	40	5006-239



Combined Static Holders



CB1 CB2 TYPE ✕ ORDER MADE, NOT REFUNDABLE. DIN 69880

CB1

- External Coolant Supply
- Right-hand

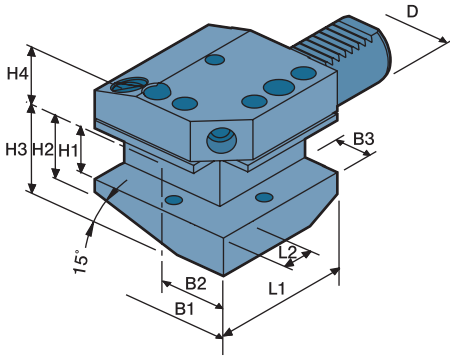

DIMENSIONS

ORDER NO.	D	B1	B2	B3	H1	H2	H3	H4	L1	L2	CODE NO.
CB1-20x16	20	65	40	14	16	19	30	25	50	14	5006-240
CB1-30x20	30	74	40	18	20	26	38	28	70	18	5006-241
CB1-40x25	40	85	45	22	25	35	48	32.5	100	22	5006-242
CB1-50x32	50	105	55	25	32	42	60	35	120	25	5006-243
CB1-60x32	60	125	62.5	30	32	46	62.5	42.5	135	30	5006-244

CB2

- Left-hand
- External Coolant Supply

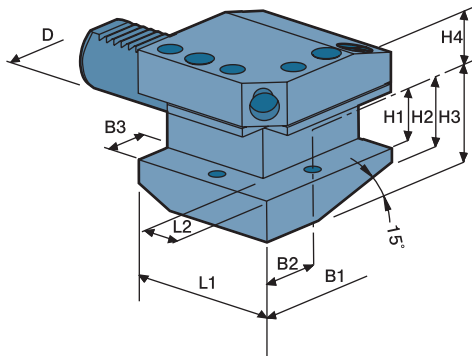

DIMENSIONS

ORDER NO.	D	B1	B2	B3	H1	H2	H3	H4	L1	L2	CODE NO.
CB2-20x16	20	65	40	14	16	19	30	25	50	14	5006-245
CB2-30x20	30	74	40	18	20	26	38	28	70	18	5006-246
CB2-40x25	40	85	47	22	25	35	48	32.5	100	22	5006-247
CB2-50x32	50	105	55	25	32	42	60	35	120	25	5006-248
CB2-60x32	60	125	62.5	30	32	46	62.5	42.5	135	30	5006-249



Combined Static Holders

CB3 CB4 TYPE

DIN 69880

CB3

- External Coolant Supply
- Right-hand

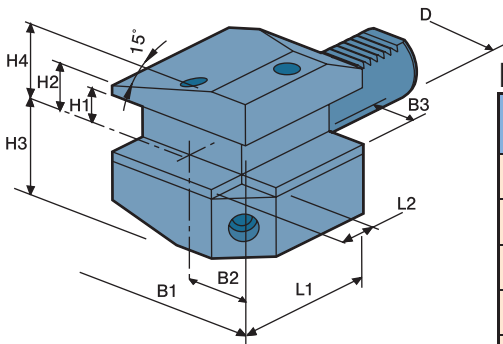

DIMENSIONS

ORDER NO.	D	B1	B2	B3	H1	H2	H3	H4	L1	L2	CODE NO.
CB3-20x16	20	65	40	14	16	19	25	30	50	14	5006-250
CB3-30x20	30	74	40	18	20	22	38	28	70	18	5006-251
CB3-40x25	40	85	45	22	25	30	48	32.5	100	22	5006-252
CB3-50x32	50	105	55	25	32	35	50	60	120	25	5006-253
CB3-60x32	60	125	62.5	30	32	42.5	62.5	62.5	135	30	5006-254

CB4

- Left-hand
- External Coolant Supply

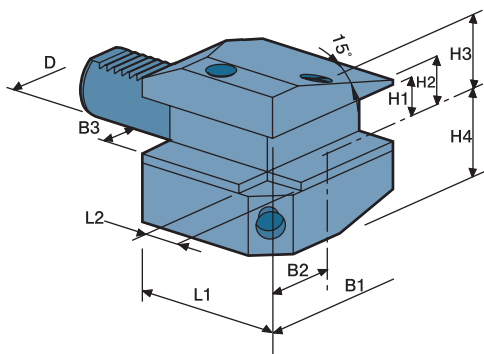

DIMENSIONS

ORDER NO.	D	B1	B2	B3	H1	H2	H3	H4	L1	L2	CODE NO.
CB4-20x16	20	65	40	14	16	19	30	25	50	14	5006-255
CB4-30x20	30	74	40	18	20	22	28	38	70	18	5006-256
CB4-40x25	40	85	47	22	25	30	32.5	48	100	22	5006-257
CB4-50x32	50	105	55	25	32	35	60	50	120	25	5006-258
CB4-60x32	60	125	62.5	30	32	42.5	62.5	62.5	135	30	5006-259



Combined Static Holders



D1 D2 TYPE

✘ ORDER MADE, NOT REFUNDABLE.

DIN 69880

D1

- Right-hand
- External Coolant Supply

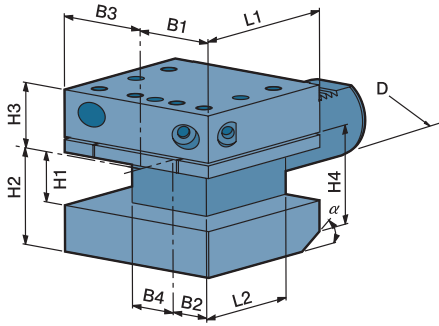

DIMENSIONS

ORDER NO.	D	B1	B2	B3	B4	H1	H2	H3	H4	L1	L2	α	CODE NO.
D1-30x20	30	35	17	41	23	20	38	35	30	60	42	25°	5006-260
D1-40x25	40	42.5	21	47.5	25.5	25	48	42.5	40	72	50	25°	5006-261
D1-50x32	50	50	26	55	30.5	32	60	50	-	85	60	-	5006-262
D1-60x32	60	57.5	33	57.5	33	32	62.5	62.5	-	110	85	-	5006-263

D2

- Left-hand
- External Coolant Supply

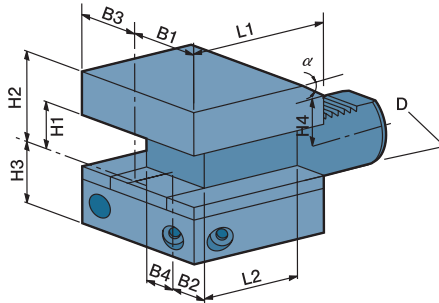

DIMENSIONS

ORDER NO.	D	B1	B2	B3	B4	H1	H2	H3	H4	L1	L2	α	CODE NO.
D2-30x20	30	35	17	41	23	20	38	35	30	60	42	25°	5006-264
D2-40x25	40	42.5	21	47.5	25.5	25	48	42.5	40	72	50	25°	5006-265
D2-50x32	50	50	26	55	30.5	32	60	50	-	85	60	-	5006-266
D2-60x32	60	57.5	33	57.5	33	32	62.5	62.5	-	110	85	-	5006-267



Static Holders

E1 TYPE

DIN 69880

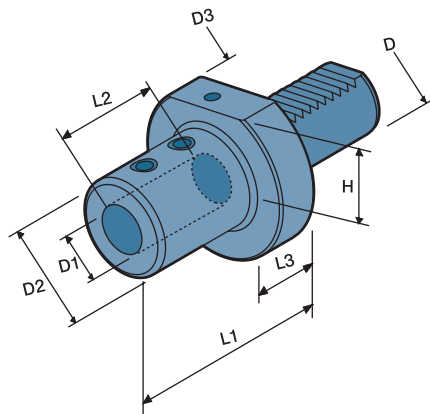

E1

- Internal Coolant Supply
- U Drills

DIMENSIONS

ORDER NO.	D	D1	D2	D3	H	L1	L2	L3	CODE NO.
E1-20x20	20	20	40	50	-	67	57	18	5006-268
E1-20x25	20	25	45	50	-	71	59	18	5006-269
E1-30x20	30	20	40	68	28	67	54	22	5006-270
E1-30x25	30	25	45	68	28	71	59	22	5006-271
E1-30x32	30	32	52	68	28	75	63	22	5006-272
E1-40x20	40	20	40	83	32.5	67	54	22	5006-273
E1-40x25	40	25	45	83	32.5	75	59	22	5006-274
E1-40x32	40	32	52	83	32.5	75	63	22	5006-275
E1-40x40	40	40	60	83	32.5	90	73	22	5006-276
E1-50x20	50	20	40	98	35	67	54	30	5006-277
E1-50x25	50	25	45	98	35	80	59	30	5006-278
E1-50x32	50	32	52	98	35	80	63	30	5006-279
E1-50x40	50	40	60	98	35	90	73	30	5006-280
E1-50x50	50	50	70	98	35	100	83	30	5006-281



Static Holders



E2 TYPE

✘ ORDER MADE, NOT REFUNDABLE. DIN 69880

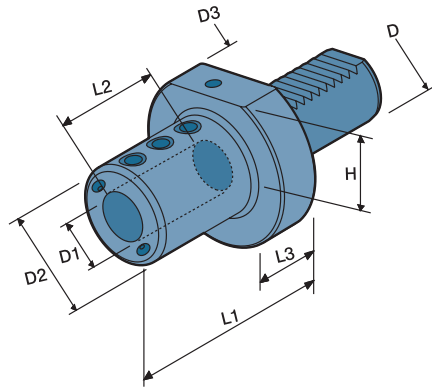

E2

- Boring Bar Holder
- External Coolant Supply

DIMENSIONS

ORDER NO.	D	D1	D2	D3	H	L1	L2	L3	CODE NO.
E2-20x8	20	8	40	50	-	50	41	18	5006-282
E2-20x10	20	10	40	50	-	50	41	18	5006-283
E2-20x12	20	12	40	50	-	50	41	18	5006-284
E2-20x16	20	16	40	50	-	50	41	18	5006-285
E2-20x20	20	20	50	50	-	50	41	-	5006-286
E2-20x25	20	25	50	50	-	60	41	-	5006-287
E2-30x8	30	8	50	68	28	60	51	22	5006-288
E2-30x10	30	10	50	68	28	60	51	22	5006-289
E2-30x12	30	12	50	68	28	60	51	22	5006-290
E2-30x16	30	16	55	68	28	60	51	22	5006-291
E2-30x20	30	20	58	68	28	60	51	22	5006-292
E2-30x25	30	25	62	68	28	60	51	22	5006-293
E2-30x32	30	32	68	68	28	75	61	-	5006-294
E2-40x10	40	10	50	83	32.5	75	61	22	5006-295
E2-40x12	40	12	50	83	32.5	75	61	22	5006-296
E2-40x16	40	16	56	83	32.5	75	61	22	5006-297
E2-40x20	40	20	56	83	32.5	75	61	22	5006-298
E2-40x25	40	25	62	83	32.5	75	61	22	5006-299
E2-40x32	40	32	72	83	32.5	75	61	22	5006-300
E2-40x40	40	40	83	83	32.5	85	76	-	5006-301
E2-50x10	50	10	50	98	35	90	76	30	5006-302
E2-50x12	50	12	56	98	35	90	76	30	5006-303
E2-50x16	50	16	56	98	35	90	76	30	5006-304
E2-50x20	50	20	62	98	35	90	76	30	5006-305
E2-50x25	50	25	72	98	35	90	76	30	5006-306
E2-50x32	50	32	72	98	35	90	76	30	5006-307
E2-50x40	50	40	80	98	35	90	76	30	5006-308
E2-50x50	50	50	90	98	35	95	86	30	5006-309
E2-60x10	60	10	68	123	42.5	90	76	35	5006-310
E2-60x12	60	12	68	123	42.5	90	76	35	5006-311
E2-60x16	60	16	68	123	42.5	90	76	35	5006-312
E2-60x20	60	20	68	123	42.5	90	76	35	5006-313
E2-60x25	60	25	68	123	42.5	90	76	35	5006-314
E2-60x32	60	32	68	123	42.5	90	76	35	5006-315
E2-60x40	60	40	98	123	42.5	90	76	35	5006-316
E2-60x50	60	50	98	123	42.5	95	86	35	5006-317



Static Holders

E2-X2 TYPE

DIN 69880

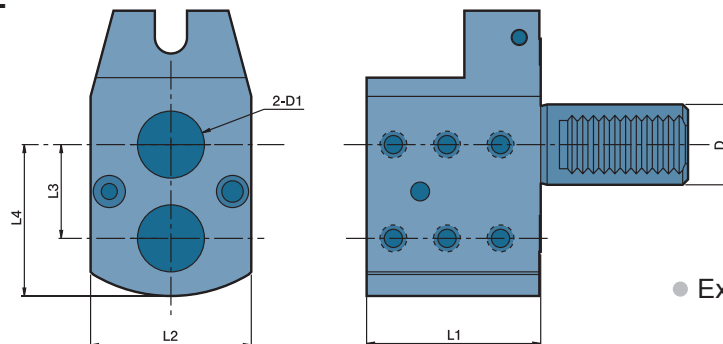

- External, internal coolant supply

DIMENSIONS

ORDER NO.	D DIN 69880	D1	L1	L2	L3	L4	CODE NO.
E2-30-2X25-35	30	25	65	60	35	56.5	5006-318
E2-40-2X40-65	40	40	85	80	65	91.5	5006-319



Static Holders



E3 E4 TYPE

※ ORDER MADE, NOT REFUNDABLE.

DIN 69880

E3

- For Collet DIN 6388
- External Coolant Supply

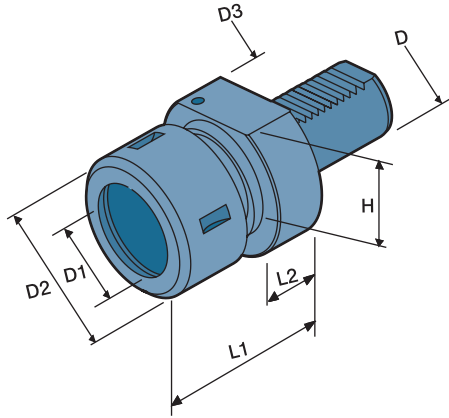

DIMENSIONS

ORDER NO.	D	D1	D2	D3	H	L1	L2	CODE NO.
E3-30-OZ25	30	2-25	60	68	28	75	22	5006-320
E3-40-OZ25	40	2-25	60	83	32.5	75	22	5006-321
E3-40-OZ32	40	4-32	78	83	32.5	90	22	5006-322
E3-50-OZ25	50	2-25	60	98	35	75	30	5006-323
E3-50-OZ32	50	4-32	78	98	35	90	30	5006-324

E4

- External Coolant Supply
- For Collet DIN 6499

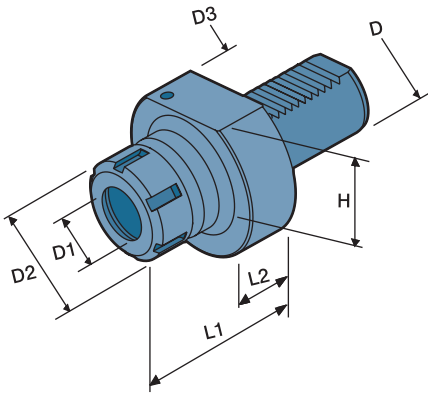

DIMENSIONS

ORDER NO.	D	D1	D2	D3	H	L1	L2	CODE NO.
E4-20-ER25	20	1-16	42	50	-	50	18	5006-325
E4-30-ER25	30	1-16	42	68	28	53	22	5006-326
E4-30-ER32	30	2-20	50	68	28	57	22	5006-327
E4-40-ER32	40	2-20	50	83	32.5	62	22	5006-328
E4-40-ER40	40	3-26	63	83	32.5	75	22	5006-329
E4-50-ER40	50	3-26	63	98	35	75	30	5006-330
E4-60-ER40	60	3-26	63	123	42.5	75	30	5006-331
E4-60-ER50	60	10-34	78	123	42.5	75	30	5006-332



Static Holders

TAPPER, CHUCK TYPE

DIN 69880

TAPPER

- External Coolant Supply
- For Collet DIN 6499

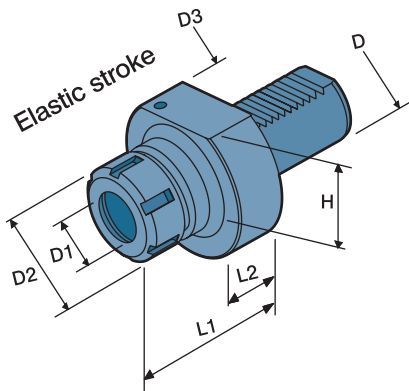

DIMENSIONS

ORDER NO.	D	D1	D2	D3	H	L1	L2	CODE NO.
TAP-20-ER20	20	1-13	34	50	-	60	18	5006-333
TAP-30-ER25	30	1-16	42	68	28	68	22	5006-334
TAP-40-ER25	40	1-16	42	83	32.5	73	22	5006-335
TAP-50-ER32	50	2-20	50	98	35	83	30	5006-336
TAP-60-ER32	60	2-20	50	123	42.5	85	30	5006-337

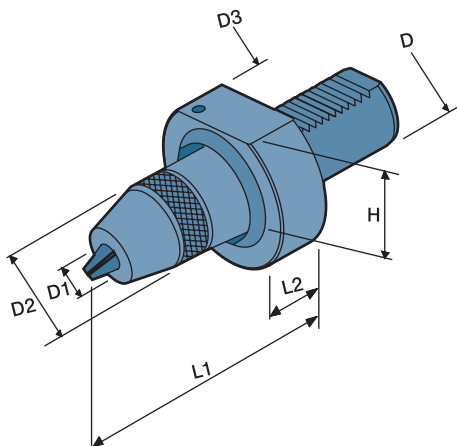

KEYLESS DRILL CHUCK

- External Coolant Supply

DIMENSIONS

ORDER NO.	D	D1	D2	D3	H	L1	L2	CODE NO.
CHUCK-30-13	30	1-13	51	68	28	85	22	5006-338
CHUCK-40-13	40	1-13	51	83	32.5	85	22	5006-339
CHUCK-40-16	40	3-16	58	83	32.5	90	22	5006-340
CHUCK-50-13	50	1-13	51	98	35	85	30	5006-341
CHUCK-50-16	50	3-16	58	98	35	90	30	5006-342



Static Holders



F TYPE

✘ ORDER MADE, NOT REFUNDABLE. DIN 69880

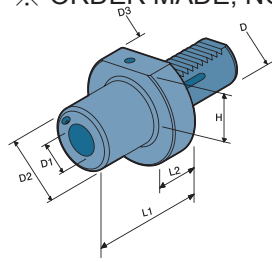

- Tool holders with morse taper according DIN 228
- External Coolant Supply

DIMENSIONS

ORDER NO.	D	D1	D2	D3	H	L1	L2	CODE NO.
F20-MT1	20	MT1	-	50	-	23	-	5006-343
F30-MT1	30	MT1	52	68	28	27	22	5006-344
F30-MT2	30	MT2	58	68	28	43	22	5006-345
F30-MT3	30	MT3	64	68	28	66	22	5006-346
F40-MT2	40	MT2	66	83	32.5	43	22	5006-347
F40-MT3	40	MT3	72	83	32.5	58	22	5006-348
F40-MT4	40	MT4	72	83	32.5	78	22	5006-349
F50-MT2	50	MT2	55	98	35	36	30	5006-350
F50-MT3	50	MT3	60	98	35	44	30	5006-351
F50-MT4	50	MT4	70	98	35	71	30	5006-352
F60-MT3	60	MT3	58	123	42.5	36	30	5006-353
F60-MT4	60	MT4	68	123	42.5	50	30	5006-354



Axial Static Holders

T1 TYPE

DIN 69880

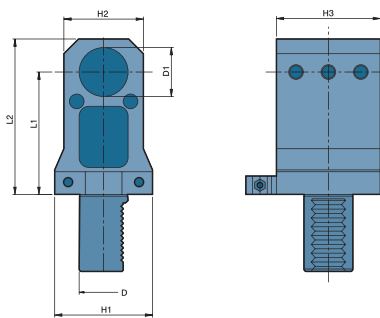

- External, internal coolant supply

DIMENSIONS

ORDER NO.	D	D1	H1	H2	H3	L1	L2	CODE NO.
T1-30-32-65	30	32	65	52	62	65	90	5006-355
T1-30-32-85	30	32	65	52	62	85	108	5006-356
T1-30-32-100	30	32	65	52	62	100	123	5006-357
T1-30-32-120	30	32	65	52	62	120	143	5006-358
T1-40-32-85	40	32	80	65	85	85	112	5006-359
T1-40-40-85	40	40	80	65	85	85	112	5006-360
T1-40-40-100	40	40	80	65	85	100	127	5006-361



Axial Static Holders

T1-X3 TYPE

DIN 69880

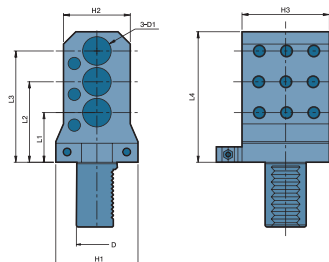

- External coolant supply

DIMENSIONS

ORDER NO.	D	D1	H1	H2	H3	L1	L2	L3	L4	CODE NO.
T1-30-3X25	30	25	65	65	62	42	85	128	148	5006-362



RS-W

- External Coolant Supply
- For Boring Bar Holder

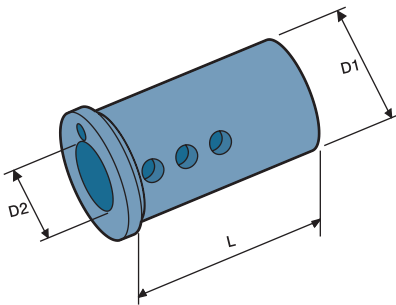

DIMENSIONS

D1	L	ORDER NO. D2	CODE NO.
20	45	E20-6	5006-369
		E20-8	5006-370
		E20-10	5006-371
25	55	E25-6	5006-372
		E25-8	5006-373
		E25-10	5006-374
		E25-12	5006-375
32	60	E32-6	5006-376
		E32-8	5006-377
		E32-10	5006-378
		E32-12	5006-379
40	75	E40-6	5006-381
		E40-8	5006-382
		E40-10	5006-383
50	85	E40-12	5006-384
		E50-8	5006-388
		E50-10	5006-389
		E50-12	5006-390
		E50-16	5006-391
		E50-20	5006-392
		E50-25	5006-393

RS

- For Boring Bar Holder

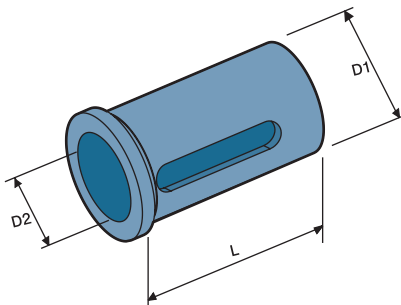

DIMENSIONS

D1	L	ORDER NO. D2	CODE NO.
20	50	E20-12-K	5006-399
		E20-16-K	5006-400
25	50	E25-16-K	5006-401A
		E25-20-K	5006-401
32	60	E32-16-K	5006-402A
		E32-20-K	5006-402B
		E32-25-K	5006-402
40	75	E40-16-K	5006-403A
		E40-20-K	5006-403B
		E40-25-K	5006-403C
		E40-32-K	5006-403
50	85	E50-32-K	5006-404A
		E50-40-K	5006-404



Reducing Sleeves



RS-MT, TE TYPE ✕ ORDER MADE, NOT REFUNDABLE.

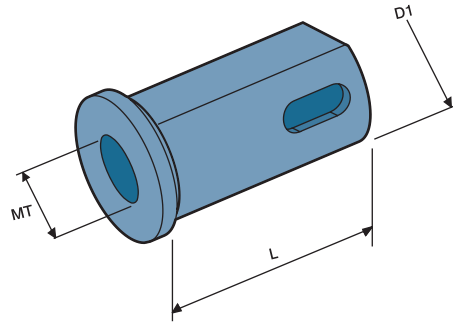

RS-MT

- Tool holders with morse taper according to DIN 228

DIMENSIONS

D1	L	MT				ORDER NO.
		1	2	3	4	
32	60	E32-MT1	E32-MT2	E32-MT3		ORDER NO.
		5006-410	5006-411	5006-412		CODE NO.
40	70	E40-MT1	E40-MT2	E40-MT3	E40-MT4	ORDER NO.
		5006-414	5006-415	5006-416	5006-417	CODE NO.
50	85	E50-MT1	E50-MT2	E50-MT3	E50-MT4	ORDER NO.
		5006-418	5006-419	5006-420	5006-421	CODE NO.

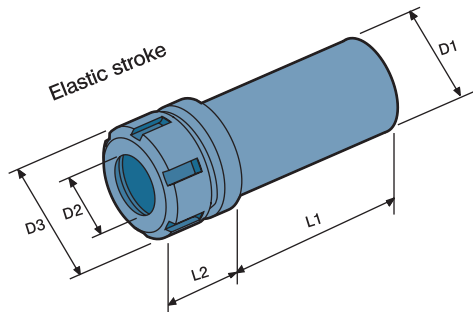

TE

- Auto taper with cylindric shaft
- To be used for collet DIN 6499

DIMENSIONS

ORDER NO.	D1	D2		D3	L1	L2	CODE NO.
TE25-ER16	25	1-10	M3-M12	ER16 32	70.5	30	5006-430
TE32-ER20	32	2-13	M3-M16	ER20 35	65	40	5006-431
TE40-ER25	40	2-16	M4-M20	ER25 42	75	43	5006-432
TE50-ER32	50	3-20	M6-M24	ER32 50	85	48	5006-433



Test Mandrel

TB1 TYPE

DIN 69880

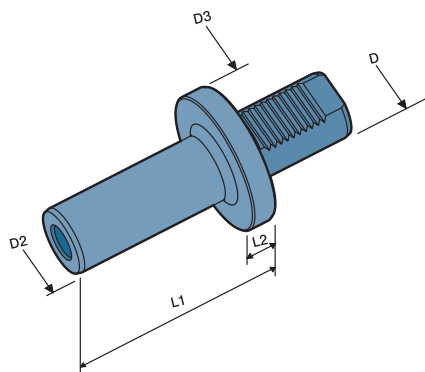

DIMENSIONS

ORDER NO.	D DIN 69880	D2	D3	L1	L2	CODE NO.
TB1-30	30	30	68	115	15	5006-434
TB1-40	40	40	83	115	15	5006-435
TB1-50	50	50	98	115	15	5006-436



H Type Milling & Drilling Head



MAZAK SUPER QUICK TURN TYPE

FOR 1ST SPINDLE

NEW

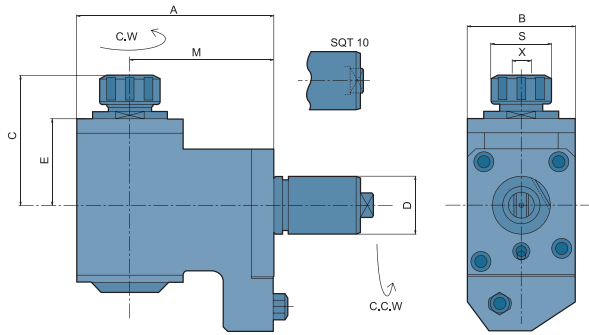

- External coolant supply
- Collet is not included
- To be used for collet DIN 6499

DIMENSIONS

ORDER NO.	Machine Type	D	X Capacity	S	Maximum R.P.M.	A	B	C	E	M	CODE NO.
SQT 10-HMD25	SQT10M-12D 15M-16D SQT200M-16D 250M-16D	40	1-16 ER25	42	5000	135	75	90	60	100	5006-440
SQT 15/18-HMD25	SQT15M-12D 18M-12D SQT200M-12D 250M-12D	40	1-16 ER25	42	5000	165	80	92	60	130	5006-441
SQT 15/18-HMD32			2-20 ER32	50	5000	165	80	96	60	130	5006-442

H Type Tapping Head

DIMENSIONS ※ ORDER MADE, NOT REFUNDABLE.

ORDER NO.	Machine Type	D	X Capacity	S	Maximum R.P.M.	A	B	C	E	M	CODE NO.
SQT 10-HT16	SQT10M-12D 15M-16D SQT200M-16D 250M-16D	40	1-10 ER16	30	3000	135	75	98	60	100	5006-443
SQT 15/18-HT20	SQT15M-12D 18M-12D SQT200M-12D 250M-12D	40	1-13 ER20	35	3000	165	80	108	60	130	5006-444



H Type Back Milling & Drilling Head

MAZAK SUPER QUICK TURN TYPE

FOR 2ND SPINDLE

NEW

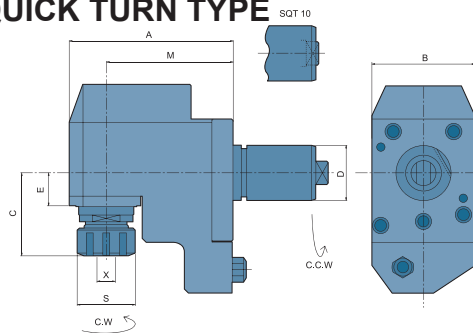

- External coolant supply
- Collet is not included
- To be used for collet DIN 6499

DIMENSIONS

ORDER NO.	Machine Type	D	X Capacity	S	Maximum R.P.M.	A	B	C	E	M	CODE NO.
SQT 10-HBMD25	SQT10M-12D 15M-16D SQT200M-16D 250M-16D	40	1-16 ER25	42	5000	135	76	43	14	100	5006-450
SQT 15/18-HBMD25	SQT15M-12D 18M-12D SQT200M-12D 250M-12D	40	1-16 ER25	42	5000	165	76	46	13	130	5006-451
SQT 15/18-HBMD32			2-20 ER32	50	5000	165	76	48	13	130	5006-452

H Type Tapping Head

DIMENSIONS

ORDER NO.	Machine Type	D	X Capacity	S	Maximum R.P.M.	A	B	C	E	M	CODE NO.
SQT 10-HBT16	SQT10M-12D 15M-16D SQT200M-16D 250M-16D	40	1-10 ER16	30	3000	135	76	51	13	100	5006-454
SQT 15/18-HBT20	SQT15M-12D 18M-12D SQT200M-12D 250M-12D	40	1-13 ER20	30	3000	165	76	79	13	130	5006-455

H Type Milling & Drilling Head

MAZAK SUPER QUICK TURN TYPE FOR 1ST AND 2ND SPINDLE



NEW

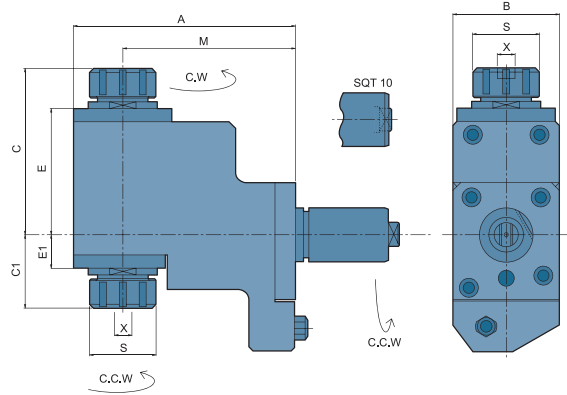

- External coolant supply
- Collet is not included
- To be used for collet DIN 6499

DIMENSIONS

ORDER NO.	Machine Type	D	X Capacity	S	Maximum R.P.M.	A	B	C	C1	E	E1	M	CODE NO.
SQT 10-HMD2025	SQT10M-12D 15M-16D SQT200M-16D 250M-16D	40	1st-ER25 2nd-ER20	42 35	4000	135	75	96	77.5	59	50	100	5006-456
SQT 15/18-HMD232	SQT15M-12D 18M-12D SQT200M-12D 250M-12D	40	2-20 ER32	42	4000	167	80	128	58	89	19	130	5006-457

V Type Milling & Drilling Head

MAZAK SUPER QUICK TURN TYPE

※ ORDER MADE, NOT REFUNDABLE.

OFFSET

NEW

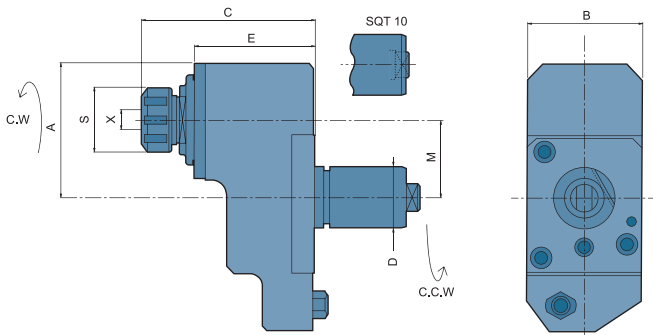

- External coolant supply
- Collet is not included
- To be used for collet DIN 6499

DIMENSIONS

※ 1:2 Speed boost

ORDER NO.	Machine Type	D	X Capacity	S	Maximum R.P.M.	A	B	C	E	M	CODE NO.
SQT 10-VMD25	SQT10M-12D 15M-16D SQT200M-16D 250M-16D	40	1-16 ER25	42	5000	88	75	120	82	50	5006-460
SQT 15/18-VMD25F	SQT15M-12D 18M-12D SQT200M-12D 250M-12D	40	1-16 ER25	42	5000	89	80	122	84	50	5006-461
SQT 15/18-VMD25F-1			1-16 ER25	42	(1:2) 7000	89	75	118	84	50	※ 5006-462
SQT 15/18-VMD32			2-20 ER32	50	5000	89	80	125.5	84	50	5006-463

V Type Tapping Head

DIMENSIONS

ORDER NO.	Machine Type	D	X Capacity	S	Maximum R.P.M.	A	B	C	E	M	CODE NO.
SQT 10-VT16F	SQT10M-12D 15M-16D SQT200M-16D 250M-16D	40	1-10 ER16	30	4000	88	75	119	81.5	50	5006-464
SQT 15/18-VT20F	SQT15M-12D 18M-12D SQT200M-12D 250M-12D	40	1-13 ER20	30	4000	89	80	123	84	50	5006-465



V Type Milling & Drilling Head

MAZAK SUPER QUICK TURN TYPE



VERTEX®

DA-SERIES

NEW

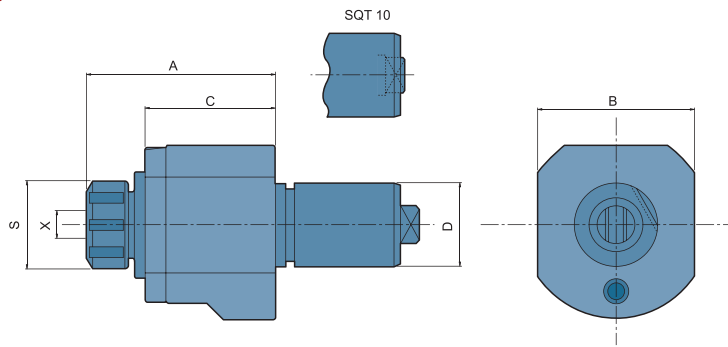

- External coolant supply
- Collet is not included
- To be used for collet DIN 6499

DIMENSIONS

ORDER NO.	Machine Type	D	X Capacity	S	Maximum R.P.M.	A	B	C	CODE NO.
SQT 10-VMD25DA	SQT10M-12D 15M-16D SQT200M-16D 250M-16D	40	1-16 ER25	42	6000	93	75	62.5	5006-466
SQT 15/18-VMD32DA	SQT15M-12D 18M-12D SQT200M-12D 250M-12D	40	2-20 ER32	50	6000	119.5	80	82.5	5006-467

V Type Tapping Head

※ ORDER MADE, NOT REFUNDABLE.

DIMENSIONS

ORDER NO.	Machine Type	D	X Capacity	S	Maximum R.P.M.	A	B	C	CODE NO.
SQT 10-VT16DA	SQT10M-12D 15M-16D SQT200M-16D 250M-16D	40	1-10 ER16	30	4000	100	75	62.5	5006-468
SQT 15/18-VT20DA	SQT15M-12D 18M-12D SQT200M-12D 250M-12D	40	1-13 ER20	35	4000	127	80	82.5	5006-469



V Type Milling & Drilling Head

MAZAK SUPER QUICK TURN TYPE

DA-SERIES, LONG

NEW

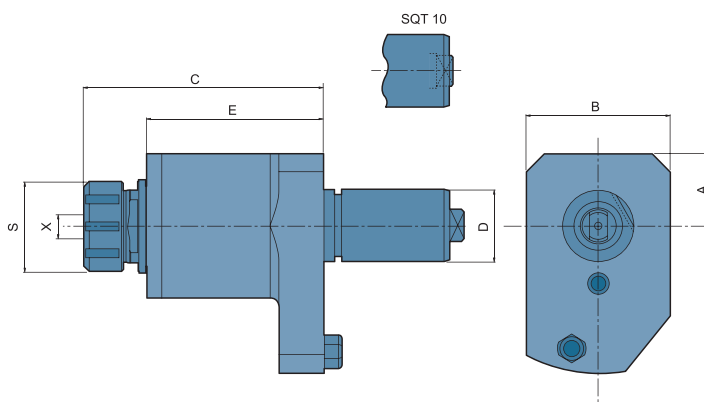

- External coolant supply
- Collet is not included
- To be used for collet DIN 6499

DIMENSIONS

ORDER NO.	Machine Type	D	X Capacity	S	Maximum R.P.M.	A	B	C	E	CODE NO.
SQT 15/18-VMD32L	SQT15M-12D 18M-12D SQT200M-12D 250M-12D	40	2-20 ER32	50	6000	40	80	119.5	82.5	5006-470
						40	80	133.5	98.5	5006-471



V Type Milling & Drilling Head



MAZAK MULTIPLEX TYPE

※ORDER MADE, NOT REFUNDABLE.

NEW

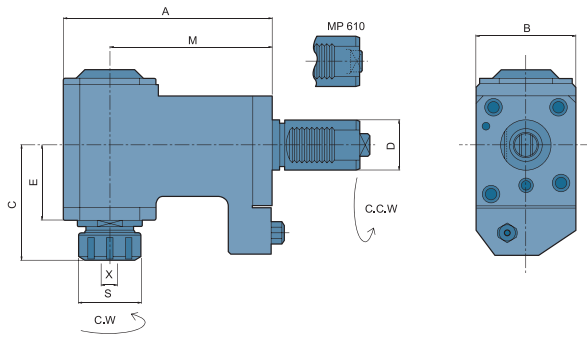

- External coolant supply
- Collet is not included
- To be used for collet DIN 6499

DIMENSIONS

※ 1:2 Speed boost

ORDER NO.	Machine Type	D	X Capacity	S	Maximum R.P.M.	A	B	C	E	M	CODE NO.
MP 610-HMD25	MP410N-12D 415N-12D MP610-12D 6200-16D	40	1-16 ER25	42	5000	150	75	80.5	50	115	5006-475
MP 620-HMD25	MP420N-12D 620N-12D MP620-12D 6200-16D	40	1-16 ER25	42	5000	165	80	80.5	50	130	5006-476
MP 620-HMD32			2-20 ER32	50	5000	165	80	82.5	50	130	5006-477
MP 620-HMD32-2			2-20 ER32	50	(1:2) 7000	169	88	103	68	130	※ 5006-478

H Type Tapping Head

DIMENSIONS

ORDER NO.	Machine Type	D	X Capacity	S	Maximum R.P.M.	A	B	C	E	M	CODE NO.
MP 610-HT16	MP410N-12D 415N-12D MP610-12D 6200-16D	40	1-10 ER16	30	3000	150	75	87.5	50	115	5006-479
MP 620-HT20	MP420N-12D 620N-12D MP620-12D 6200-16D	40	1-13 ER20	30	3000	165	80	115.5	56	130	5006-480



V Type Milling & Drilling Head

MAZAK MULTIPLEX TYPE

OFFSET

NEW

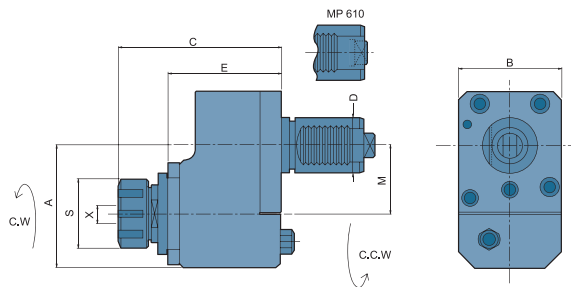

- External coolant supply
- Collet is not included
- To be used for collet DIN 6499

DIMENSIONS

ORDER NO.	Machine Type	D	X Capacity	S	Maximum R.P.M.	A	B	C	E	M	CODE NO.
MP 610-VMD25F	MP410N-12D 415N-12D MP610-12D 6200-16D	40	1-16 ER25	42	5000	89	75	122	84	50	5006-481
MP 620-VMD16F	MP420N-12D 620N-12D MP620-12D 6200-16D	40	1-16 ER25	42	5000	89	80	122	84	50	5006-482
MP 620-VMD32F			2-20 ER32	50	5000	89	80	125.5	84	50	5006-483

V Type Tapping Head

DIMENSIONS

ORDER NO.	Machine Type	D	X Capacity	S	Maximum R.P.M.	A	B	C	E	M	CODE NO.
MP 610-VT16F	MP410N-12D 415N-12D MP610-12D 6200-16D	40	1-10 ER16	30	4000	89	75	122	82.5	50	5006-484
MP 620-VT20F	MP420N-12D 620N-12D MP620-12D 6200-16D	40	1-13 ER20	35	4000	89	80	123.5	84	50	5006-485



V Type Milling & Drilling Head

MAZAK MULTIPLEX TYPE



VERTEX®

DA-SERIES

NEW

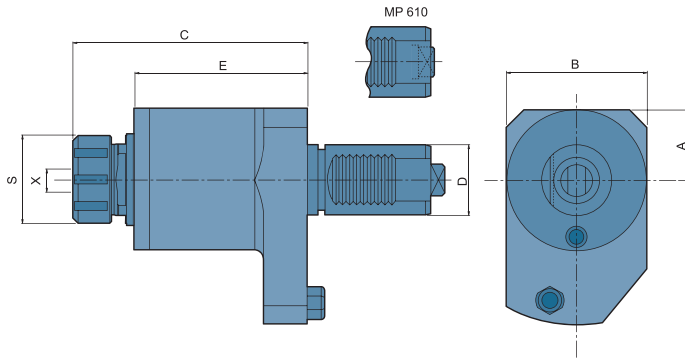

- External coolant supply
- Collet is not included
- To be used for collet DIN 6499

DIMENSIONS

ORDER NO.	Machine Type	D	X Capacity	S	Maximum R.P.M.	A	B	C	E	CODE NO.
MP 610-VMD25DA	MP410N-12D 415N-12D MP610-12D 6200-16D	40	1-16 ER25	42	6000	39	75	108	74	5006-486
MP 620-VMD25DA	MP420N-12D 620N-12D MP620-12D 6200-16D	40	1-16 ER25	42	6000	40	80	119	82.6	5006-487
MP 620-VMD32DA			2-20 ER32	50	6000	40	80	120	82.6	5006-488



Forward Turning Holder - RH

MAZAK SUPER QUICK TURN & MULTIPLEX TYPE

※ORDER MADE, NOT REFUNDABLE.

NEW

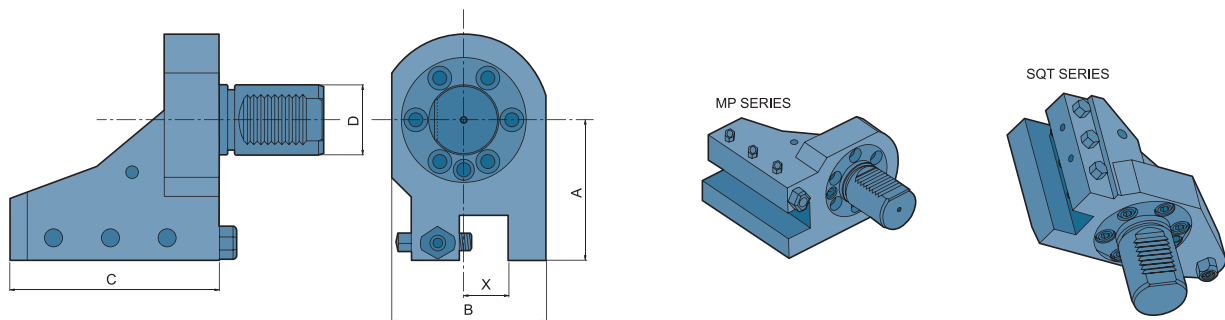

DIMENSIONS

ORDER NO.	Machine Type	D		X	A	B	C	CODE NO.
SQT 10M/15AM-FTRH-M	SQT-10M/15AM	40	mm	20	66	79	100	5006-490
SQT 10M/15AM-FTRH-I			inch	0.75"	2.6"	3.1"	3.937"	5006-491
SQT 15M/18M-FTRH-M	SQT-15M/18M	40	mm	25	78	92	120	5006-492
SQT 15M/18M-FTRH-I			inch	1"	3.071"	3.622"	4.724"	5006-493
MP 610N/615N-FTRH-M	MP-610N/615N	40	mm	20	85	76	100	5006-496
MP 410N/415N-FTRH-I	MP-410N/415N		inch	0.75"	3.347"	3"	3.937"	5006-497
MP 620N/625N-FTRH-M	MP-620N/625N	40	mm	25	83	92	120	5006-498
MP 420N-FTRH-I	MP-420N		inch	1"	3.268"	3.622"	4.724"	5006-499



Reverse Turning Holder - LH



MAZAK SUPER QUICK TURN & MULTIPLEX TYPE ※ORDER MADE, NOT REFUNDABLE.

NEW

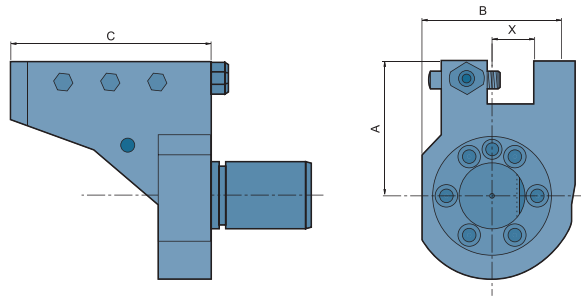

SQT SERIES

MP SERIES

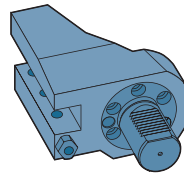
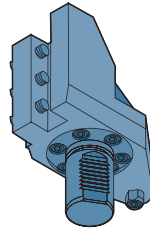

DIMENSIONS

ORDER NO.	Machine Type	D		X	A	B	C	CODE NO.
SQT 10M/15AM-RTLH-M	SQT-10M/15AM	40	mm	20	66	76	100	5006-502
SQT 10M/15AM-RTLH-I			inch	0.75"	2.6"	3"	3.937"	5006-503
SQT 15M/18M-RTLH-M	SQT-15M/18M	40	mm	25	78	92	120	5006-504
SQT 15M/18M-RTLH-I			inch	1"	3.071"	3.622"	4.724"	5006-505
SQT 28M/30M-RTLH-M	SQT-28M/30M	50	mm	25	80	94	160	5006-506
SQT 28M/30M-RTLH-I			inch	1"	3.15"	3.7"	6.3"	5006-507
MP 610N/615N-RTLH-M	MP-610N/615N	40	mm	20	85	76	100	5006-508
MP 410N/415N-RTLH-I	MP-410N/415N		inch	0.75"	3.347"	3"	3.937"	5006-509
MP 620N/625N-RTLH-M	MP-620N/625N	40	mm	25	83	92	120	5006-510
MP 420N-RTLH-I	MP-420N		inch	1"	3.268"	3.622"	4.724"	5006-511

※ ON REQUEST



Double Turning Holder

MAZAK SUPER QUICK TURN TYPE

NEW

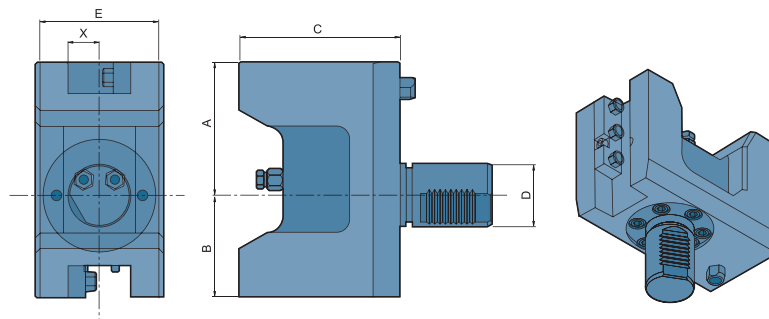

DIMENSIONS

ORDER NO.	Machine Type	D		X	A	B	C	E	CODE NO.
SQT 10M/15AM-DT-M	SQT-10M/15AM	40	mm	20	85	65	103	81	5006-514
SQT 10M/15AM-DT-I			inch	0.75"	3.347"	2.559"	4.055"	3.189"	5006-515
SQT 15M/18M-DT-M	SQT-15M/18M	40	mm	25	88	78	136	100	5006-516
SQT 15M/18M-DT-I			inch	1"	3.465"	3.071"	5.354"	3.937"	5006-517



Boring Bar Holder

MAZAK SUPER QUICK TURN TYPE



※ORDER MADE, NOT REFUNDABLE.

NEW

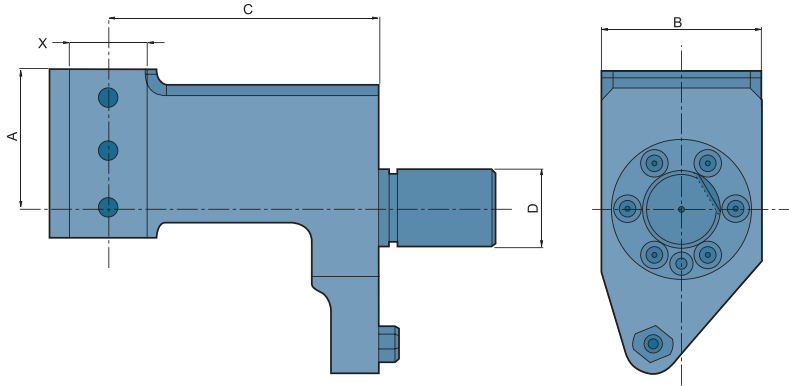

DIMENSIONS

ORDER NO.	Machine Type	D		X	A	B	C	CODE NO.
SQT 10M/15AM-B-M	SQT-10M/15AM	40	mm	32	55.5	76	110	5006-520
SQT 10M/15AM-B-I			inch	1.25"	2.185"	2.992"	4.331"	5006-521
SQT 15M/18M-B-M	SQT-15M/18M	40	mm	40	71	82	140	5006-522
SQT 15M/18M-B-I			inch	1.5"	2.795"	3.228"	5.512"	5006-523
SQT 28M/30M-B-M	SQT-28M/30M	50	mm	50	65	94	175	5006-524
SQT 28M/30AM-B-I			inch	2"	2.559"	3.7"	6.890"	5006-525



Boring Bar Holder

MAZAK MULTIPLEX TYPE

NEW

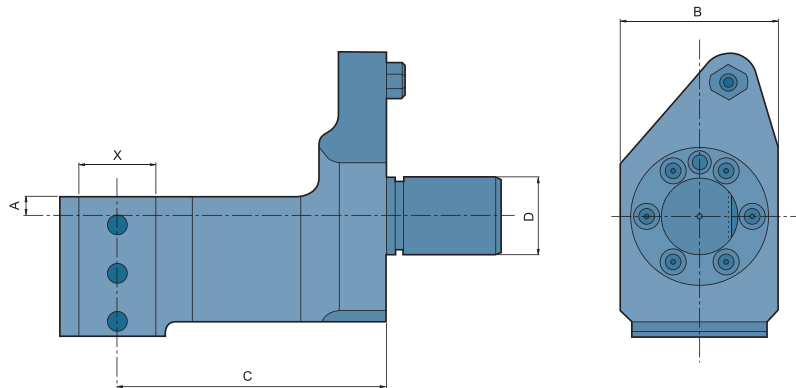

DIMENSIONS

ORDER NO.	Machine Type	D		X	A	B	C	CODE NO.
MP-610N-B-A	MP-610N	40	mm	25	55.5	76	120	5006-526
MP-610N-B-B			inch	1"	0.197"	2.997"	4.724"	5006-527
MP-610N-B-C			mm	32	10	76	120	5006-528
MP-610N-B-D			inch	1.25"	0.394"	2.997"	4.724"	5006-529
MP-615N-B-A	MP-615N	40	mm	25	10	76	130	5006-530
MP-615N-B-B			inch	1"	0.394"	2.997"	5.118"	5006-531
MP-615N-B-C			mm	32	10	76	130	5006-532
MP-615N-B-D			inch	1.25"	0.394"	2.997"	5.118"	5006-533
MP-620N-B-A	MP-620N	40	mm	25	5	62	140	5006-534
MP-620N-B-B			inch	1"	0.197"	3.228"	5.512"	5006-535
MP-620N-B-C			mm	40	10	82	140	5006-536
MP-620N-B-D			inch	1.5"	0.394"	3.228"	5.512"	5006-537



Double Boring Bar Holder



MAZAK SUPER QUICK TURN TYPE

※ORDER MADE, NOT REFUNDABLE.

NEW

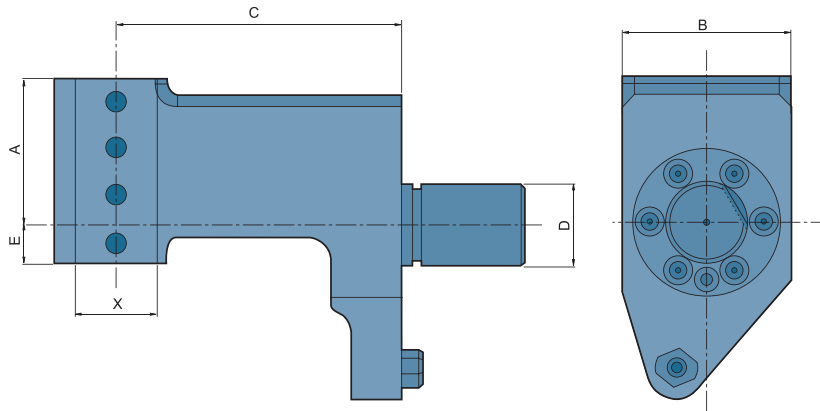

DIMENSIONS

ORDER NO.	Machine Type	D		X	A	B	C	E	CODE NO.
SQT 10M/15AM-DB-M	SQT-10M/15AM	40	mm	20	55.5	76	110	14.5	5006-540
SQT 10M/15AM-DB-I			inch	0.75"	2.185"	3"	4.331"	0.57"	5006-541
SQT 15M/18M-DB-M	SQT-15M/18M	40	mm	25	85	82	140	16	5006-542
SQT 15M/18M-DB-I			inch	1"	3.346"	3.228"	5.512"	0.629"	5006-543
SQT 28M/30M-DB-M	SQT-28M/30M	50	mm	32	75	94	175	35	5006-544
SQT 28M/30M-DB-I			inch	1.25"	2.953"	3.543"	7.087"	1.378"	5006-545



U Drill Holder

MAZAK SUPER QUICK TURN TYPE

NEW

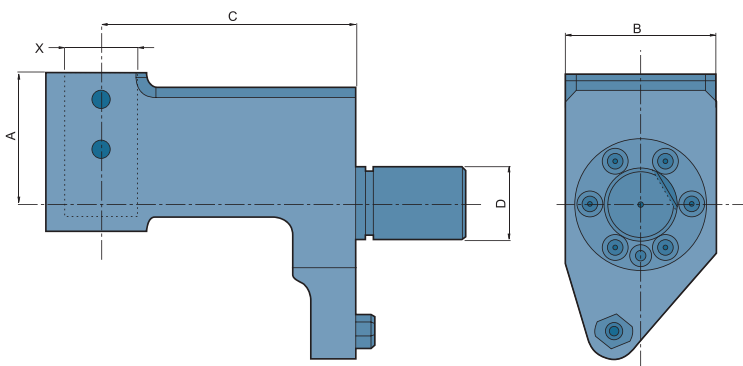

● External, internal coolant supply

DIMENSIONS

ORDER NO.	Machine Type	D		X	A	B	C	CODE NO.
SQT 10M/15AM-UD-M	SQT-10M/15AM	40	mm	32	48	76	110	5006-550
SQT 10M/15AM-UD-I			inch	1.25"	1.890"	2.992"	4.331"	5006-551
SQT 15M/18M-UD-M	SQT-15M/18M	40	mm	40	63	82	140	5006-552
SQT 15M/18M-UD-I			inch	1.5"	2.480"	3.228"	5.512"	5006-553



U Drill Holder

MAZAK MULTIPLEX TYPE



※ORDER MADE, NOT REFUNDABLE.

NEW

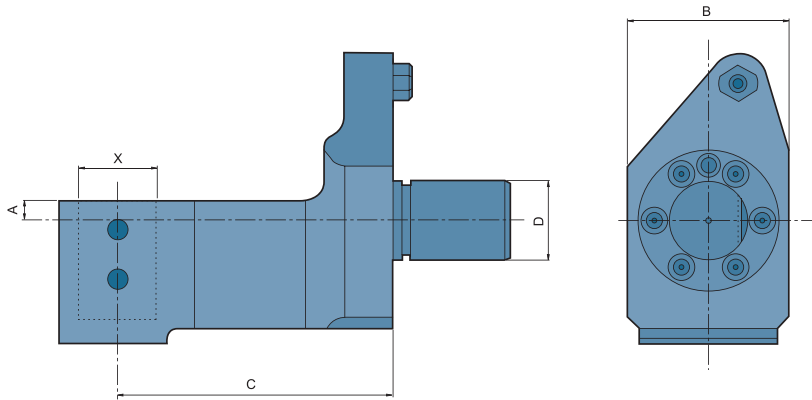

● External, internal coolant supply

DIMENSIONS

ORDER NO.	Machine Type	D		X	A	B	C	CODE NO.
MP-610-UD-M	MP-610	40	mm	25	10	76	120	5006-560
MP-610-UD-I			inch	-	0.394"	2.992"	4.724"	5006-561
MP-620-UD-M	MP-620	40	mm	40	10	82	140	5006-562
MP-620-UD-I			inch	-	0.394"	3.228"	5.512"	5006-563



Facing Holder - RH

MAZAK SUPER QUICK TURN & MULTIPLEX TYPE

NEW

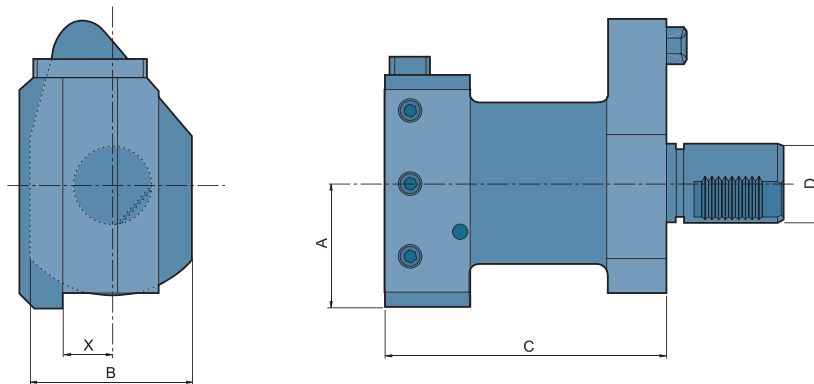

DIMENSIONS

ORDER NO.	Machine Type	D		X	A	B	C	CODE NO.
SQT 10M/15AM-FRH-M	SQT-10M/15AM	40	mm	20	65	76	110	5006-570
SQT 10M/15AM-FRH-I			inch	0.75"	2.559"	2.992"	4.331"	5006-571
SQT 15M/18M-FRH-M	SQT-15M/18M	40	mm	25	60	82	143	5006-572
SQT 15M/18M-FRH-I			inch	1"	2.362"	3.228"	5.630"	5006-573
SQT 28M/30M-FRH-M	SQT-28M/30M	50	mm	25	57	90	163	5006-574
SQT 28M/30M-FRH-I			inch	1"	2.244"	3.543"	6.417"	5006-575
MP 610N/615N-FRH-M	MP-610N/615N	40	mm	20	65	76	110	5006-576
MP 410N/415N-FRH-I	MP-410N/415N		inch	0.75"	2.559"	2.992"	4.331"	5006-577
MP 620N/625N-FRH-M	MP-620N/625N	40	mm	25	55	82	143	5006-578
MP 420N-FRH-I	MP-420N		inch	1"	2.165"	3.228"	5.630"	5006-579

Radial Drilling And Milling Heads

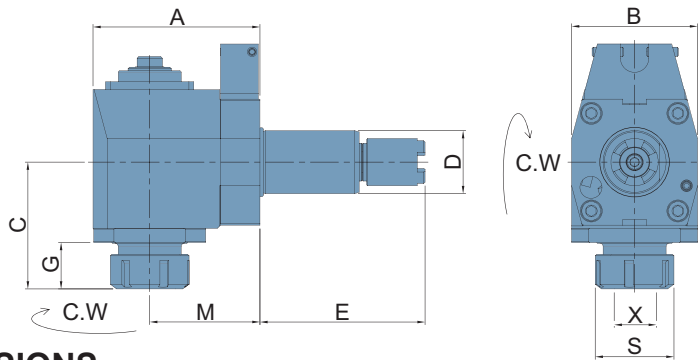

TYPE HAAS

- 1.External coolant supply
- 2.To be used for collet DIN 6499
- 3.Collet is not included

DIMENSIONS

ORDER NO.	D	X capacity	S	Maximum R.P.M.	A	B	C	G	M	E	MODELS	CODE NO.
VDI-40-FL40-32-104	40	2-20 ER32	50	4000	106	80	85	34	70	104.85	SL-20/TL-15	5006-600
117.55										SL-30/TL-25 SL-40	5006-601	
130.35										SL-40	5006-602	

Axial Milling And Drilling Heads

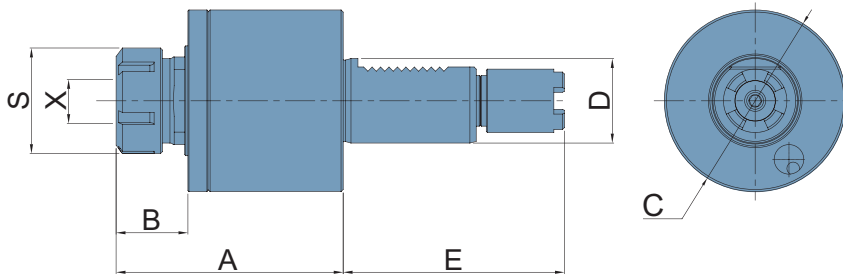

※ORDER MADE, NOT REFUNDABLE.

- 1.External coolant supply
- 2.To be used for collet DIN 6499
- 3.Collet is not included

DIMENSIONS

ORDER NO.	D	X capacity	S	Maximum R.P.M.	A	B	C	E	MODELS	CODE NO.
VDI-40-DA40-32104	40	2-20 ER32	50	6000	109	34	86	104.85	SL-20/TL-15	5006-610
117.55								SL-30/TL-25	5006-611	
130.25								SL-40	5006-612	

Reducing Sleeves

RS-W, RS TYPE

RS-W

- External Coolant Supply
- For Boring Bar Holder

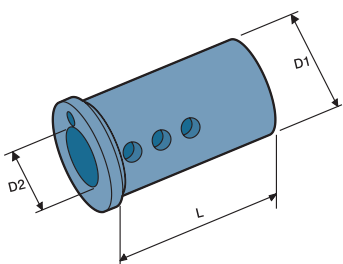

DIMENSIONS

D1	L	ORDER NO. D2	CODE NO.
20	45	E20-6	5006-369
		E20-8	5006-370
		E20-10	5006-371
25	55	E25-6	5006-372
		E25-8	5006-373
		E25-10	5006-374
		E25-12	5006-375
32	60	E32-6	5006-376
		E32-8	5006-377
		E32-10	5006-378
		E32-12	5006-379
40	75	E40-6	5006-381
		E40-8	5006-382
		E40-10	5006-383
		E40-12	5006-384
50	85	E50-8	5006-388
		E50-10	5006-389
		E50-12	5006-390
		E50-16	5006-391
		E50-20	5006-392
		E50-25	5006-393

RS

- For Boring Bar Holder

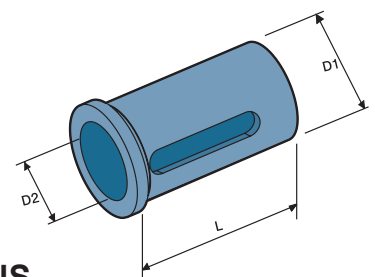

DIMENSIONS

D1	L	ORDER NO. D2	CODE NO.
20	50	E20-12-K	5006-399
		E20-16-K	5006-400
25	50	E25-16-K	5006-401A
		E25-20-K	5006-401
32	60	E32-16-K	5006-402A
		E32-20-K	5006-402B
		E32-25-K	5006-402
40	75	E40-16-K	5006-403A
		E40-20-K	5006-403B
		E40-25-K	5006-403C
		E40-32-K	5006-403
50	85	E50-32-K	5006-404A
		E50-40-K	5006-404

TYPE HAAS

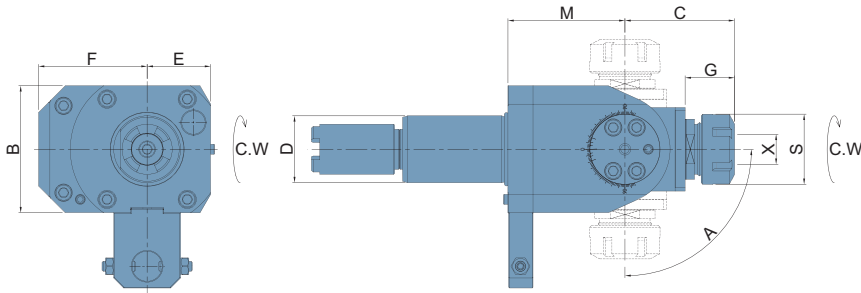

- 1.External coolant supply
- 2.To be used for collet DIN 6499
- 3.Collet is not included

DIMENSIONS

ORDER NO.	D DIN 69880	X capacity	Maximum R.P.M.	S	A	B	C	E	F	G	M	CODE NO.
VDI-40-DA40-25B-117	40	2-16 ER25	4000	42	±90°	76	65.5	38	65	29.5	70	5006-621
VDI-40-DA40-32B-117		2-20 ER32		50			88.5			52.5		5006-622

Axial Drilling And Milling Heads

※ORDER MADE, NOT REFUNDABLE.

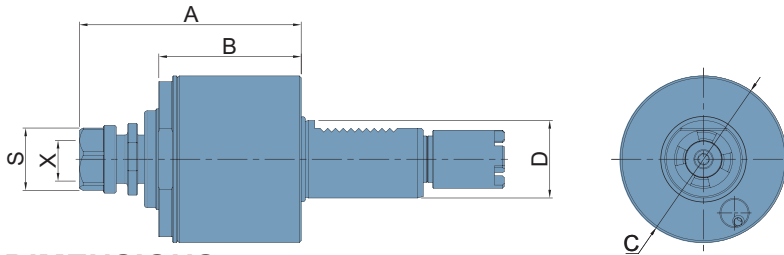

- 1.External coolant and intermediate rings supply
- 2.To be used for cutter arbor according to DIN 6358

DIMENSIONS

ORDER NO.	D DIN 69880	X capacity	Maximum R.P.M.	S	i	A	B	C	CODE NO.
VDI-40-TDA40-20-104.85	40	1-13 ER20	3000	35	1:1	114.5	74.5	86	5006-631

Reducing Sleeves

RS-W, RS TYPE

RS-MT

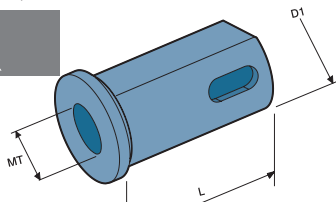

- Tool holders with morse taper according to DIN 228

DIMENSIONS

D1	L	MT				ORDER NO.	CODE NO.
		1	2	3	4		
32	60	E32-MT1	E32-MT2	E32-MT3		ORDER NO.	
		5006-410	5006-411	5006-412		CODE NO.	
40	70	E40-MT1	E40-MT2	E40-MT3	E40-MT4	ORDER NO.	
		5006-414	5006-415	5006-416	5006-417	CODE NO.	
50	85	E50-MT1	E50-MT2	E50-MT3	E50-MT4	ORDER NO.	
		5006-418	5006-419	5006-420	5006-421	CODE NO.	

TE

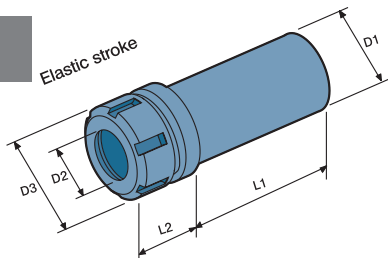

- Auto taper with cylindric shaft
- To be used for collet DIN 6499

DIMENSIONS

ORDER NO.	D1	D2		D3	L1	L2	CODE NO.
TE25-ER16	25	1-10	M3-M12	ER16 32	70.5	30	5006-430
TE32-ER20	32	2-13	M3-M16	ER20 35	65	40	5006-431
TE40-ER25	40	2-16	M4-M20	ER25 42	75	43	5006-432
TE50-ER32	50	3-20	M6-M24	ER32 50	85	48	5006-433

Test Mandrel

TB1 TYPE

DIN 69880

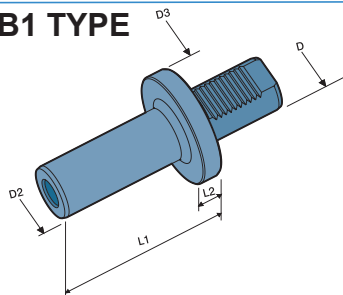

DIMENSIONS

ORDER NO.	D DIN 69880	D2	D3	L1	L2	CODE NO.
TB1-30	30	30	68	115	15	5006-434
TB1-40	40	40	83	115	15	5006-435
TB1-50	50	50	98	115	15	5006-436



Radial Milling And Drilling Head



OKUMA TYPE

90°

NEW

- External Coolant Supply
- Collet is not included
- To be used for collet DIN 6499

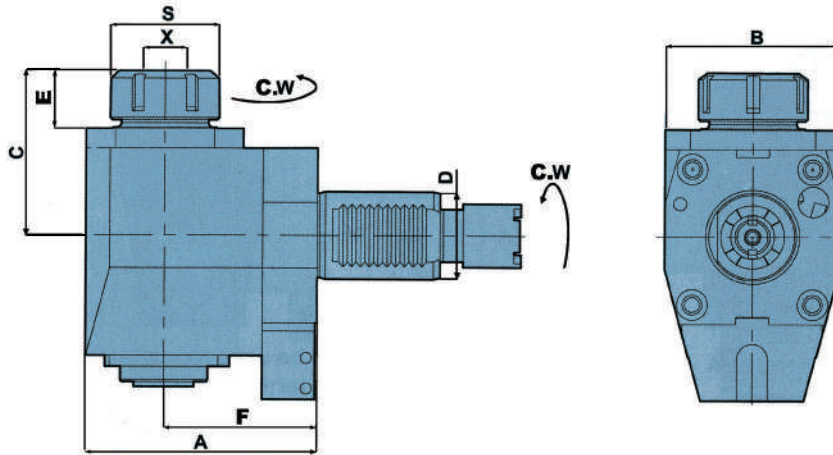

DIMENSIONS

ORDER NO.	OKUMA TYPE	D	X capacity	S	Maximum R.P.M.	A	B	C	E	F	CODE NO.
OKM-FL40-32-70	L300M	40	2-20 ER32	50	5000	106	80	75	26	70	5006-650



Axial Milling And Drilling Head

0°

NEW

- External Coolant Supply
- Collet is not included
- To be used for collet DIN 6499

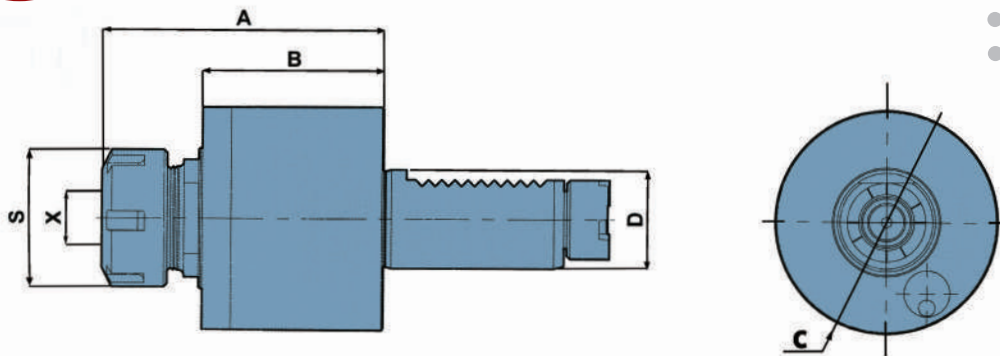

DIMENSIONS

ORDER NO.	OKUMA TYPE	D	X capacity	S	Maximum R.P.M.	A	B	C	CODE NO.
OKM-DA30-ER20	L200M	30	1-13 ER20	35	6000	84.5	57	68	5006-656
OKM-DA30-ER25	L200M	30	1-16 ER25	42	6000	86	55	68	5006-657
OKM-DA40-ER32	L300M	40	2-20 ER32	50	6000	106	74	86	5006-658



Radial Milling And Drilling Head



OKUMA TYPE

90°

NEW

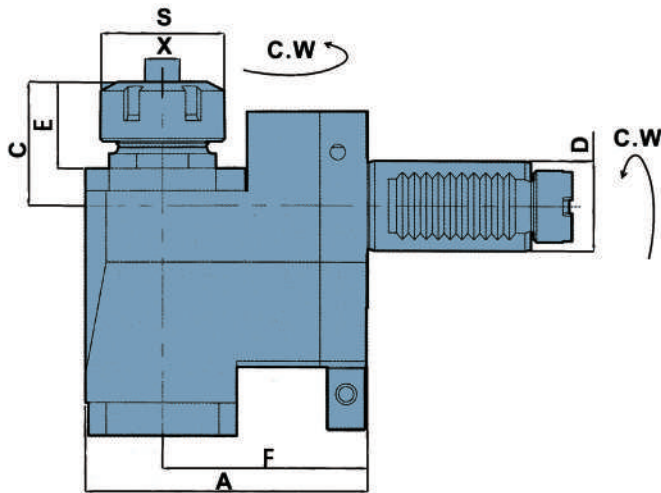

- External Coolant Supply
- Collet is not included
- To be used for collet DIN 6499

DIMENSIONS

ORDER NO.	OKUMA TYPE	D	X capacity	S	Maximum R.P.M.	A	B	C	E	F	CODE NO.
OKM-BL30-20-69-N	L200M	30	1-13 ER20	35	5000	95	64	43	30	69	5006-665
OKM-BL30-25-69-N	L200M	30	1-16 ER25	42	5000	95	64	42.5	30	69	5006-666
OKM-BL40-32-90	L300M	40	2-20 ER32	50	5000	124	80	42.5	29	90	5006-667



Angular Heads

NEW

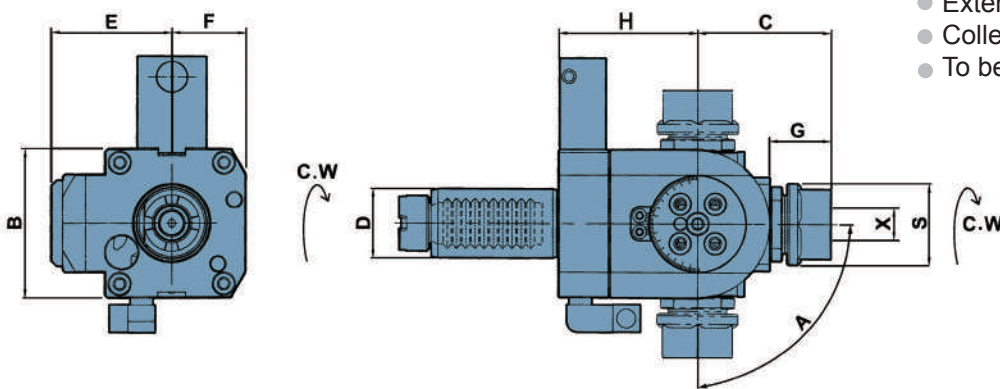

- External Coolant Supply
- Collet is not included
- To be used for collet DIN 6499

DIMENSIONS

ORDER NO.	OKUMA TYPE	D	X capacity	S	Maximum R.P.M.	A	B	C	E	F	G	H	CODE NO.
OKM-DA30-20B	L200M	30	1-13 ER20	35	4000	±90°	64	59	54	32	27	67	5006-671
OKM-DA40-25B	L300M	40	1-16 ER25	42	4000	±90°	76	65	65	38	29	70	5006-672



Radial Milling And Drilling Head



OKUMA TYPE

90°

NEW

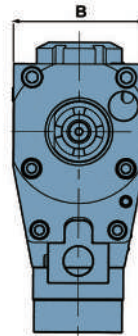
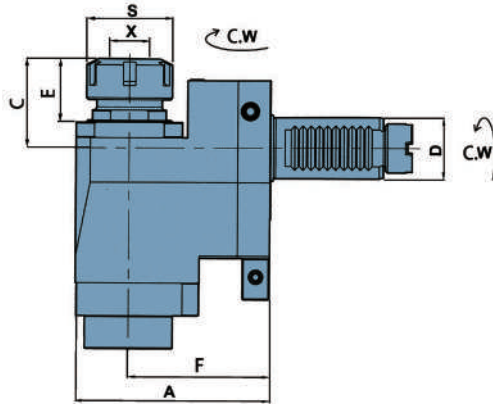

- Internal coolant supply
- Collet is not included
- To be used for collet DIN 6499

DIMENSIONS

ORDER NO.	OKUMA TYPE	D	X capacity	S	Maximum R.P.M.	A	B	C	E	F	CODE NO.
OKM-CW-BL30-25-69	L200M	30	1-16 ER25	42	5000	95	64	43.5	31	69	5006-675



Axial Milling And Drilling Head

0°

NEW

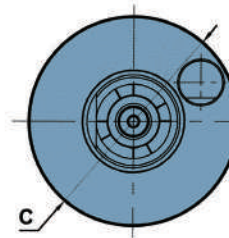
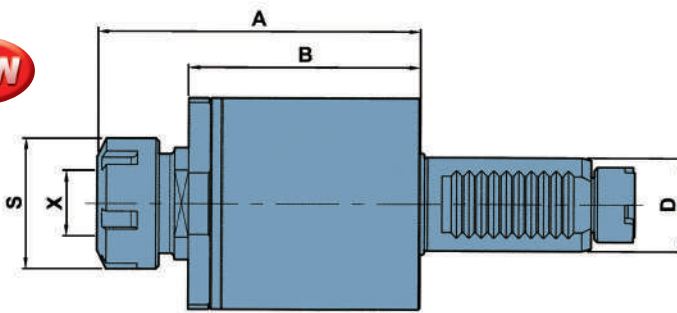

- Internal coolant supply
- Collet is not included
- To be used for collet DIN 6499

DIMENSIONS

ORDER NO.	OKUMA TYPE	D	X capacity	S	Maximum R.P.M.	A	B	C	CODE NO.
OKM-CW-DA30-ER25	L200M	30	1-16 ER25	42	6000	104	74.5	68	5006-678



Angular Heads

OKUMA TYPE

NEW

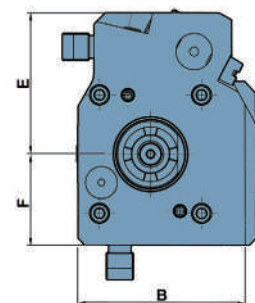
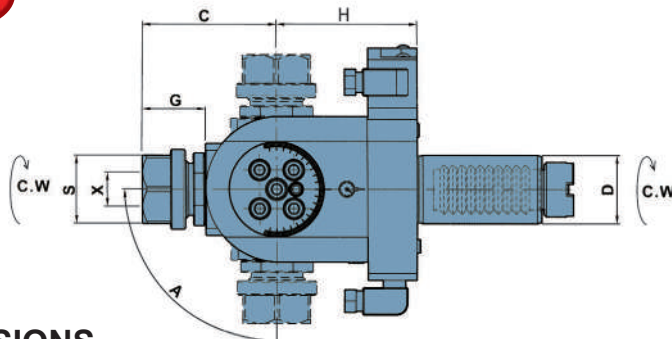

- External Coolant Supply
- Collet is not included
- To be used for collet DIN 6499

DIMENSIONS

ORDER NO.	OKUMA TYPE	D	X capacity	S	Maximum R.P.M.	A	B	C	G	E	F	H	CODE NO.
OKM-LT-DA30-20B	LT200-MY	30	1-13 ER20	35	4000	±90°	74	59	27	62	40	67	5006-682



Boring Bar Holder



OKUMA TYPE

NEW

● Internal Coolant supply

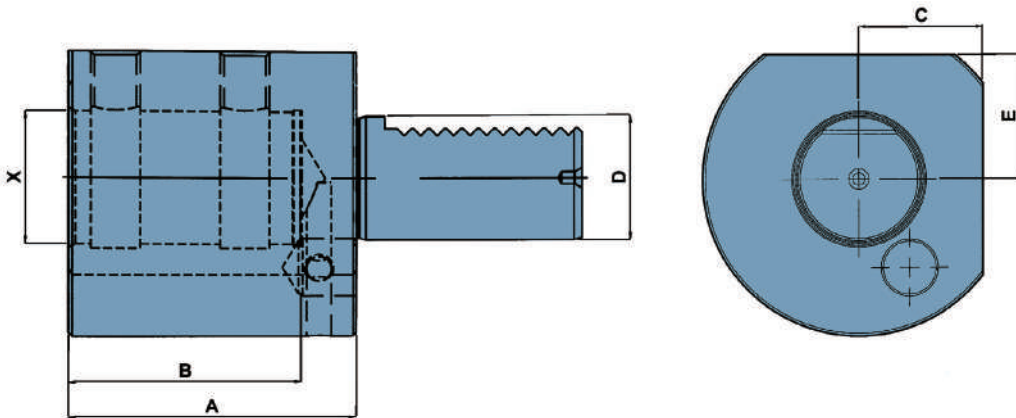

DIMENSIONS

ORDER NO.	OKUMA TYPE	D	X	A	B	C	E	CODE NO.
OKM-4162-2707-10	L200M	30	32(MM)	70	56.5	30.5	30.5	5006-686
OKM-4163-2785-10	L300M	40	1.5"(INCH)	75	65	34.5	34.5	5006-687
OKM-4163-2723-10		40	40(MM)	75	60	34.5	34.5	5006-688



Boring Bar Holder

● External Coolant Supply

NEW

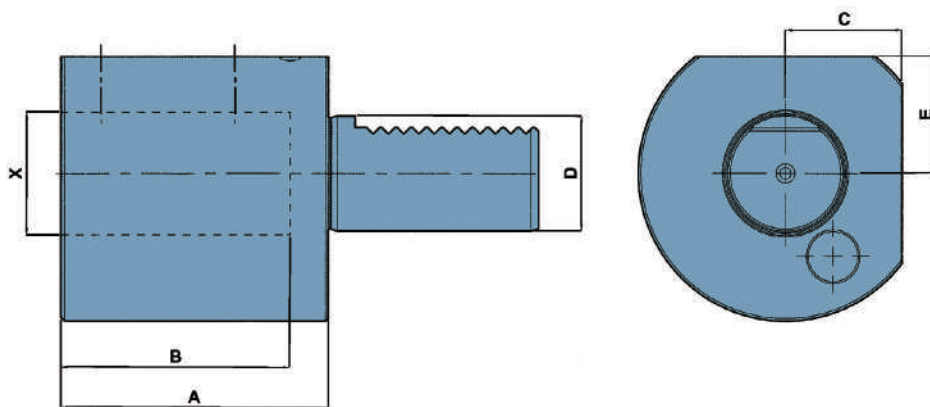

DIMENSIONS

ORDER NO.	OKUMA TYPE	D	X	A	B	C	E	CODE NO.
OKM-4167-2610-10	L200M	30	1.25"(INCH)	70	60	30.5	30.5	5006-692
OKM-4167-2604-10		30	32(MM)	70	60	30.5	30.5	5006-693
OKM-4163-2769-11	L300M	40	1.5"(INCH)	75	65	34.5	34.5	5006-694
OKM-4163-2704-12		40	40(MM)	75	60	34.5	34.5	5006-695



Turning Holder

OKUMA TYPE



NEW

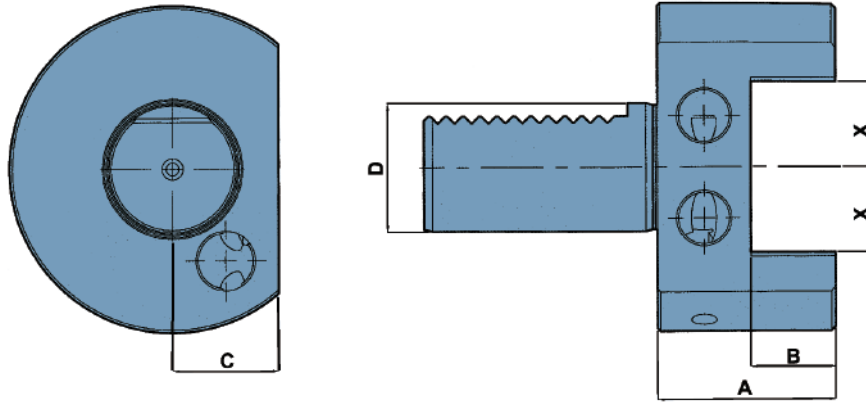

DIMENSIONS

ORDER NO.	OKUMA TYPE	D	X	A	B	C	CODE NO.
OKM-A4167-2607-10	L200M	30	0.75" (INCH)	42	0.75" (INCH)	25	5006-700
OKM-A4167-2601-10		30	20 (MM)	42	20 (MM)	25	5006-701
OKM-B4167-2608-10	L200M	30	0.75" (INCH)	42	0.75" (INCH)	55	5006-702
OKM-B4167-2602-10		30	20 (MM)	42	20 (MM)	55	5006-703
OKM-A4163-2766-11	L300M	40	1" (INCH)	47	1" (INCH)	30	5006-704
OKM-A4163-2701-11		40	25 (MM)	47	25 (MM)	30	5006-705
OKM-B4163-2676-11	L300M	40	1" (INCH)	47	1" (INCH)	65	5006-706
OKM-B4163-2702-11		40	25 (MM)	47	25 (MM)	65	5006-707



Facing Holder

NEW

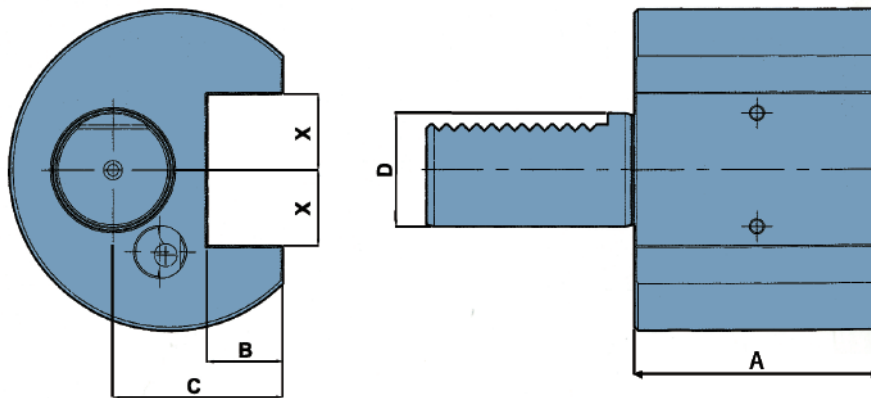

DIMENSIONS

ORDER NO.	OKUMA TYPE	D	X	A	B	C	CODE NO.
OKM-C4167-2609-10	L200M	30	0.75" (INCH)	65	0.75" (INCH)	45	5006-711
OKM-C4167-2603-10		30	20 (MM)	65	20 (MM)	45	5006-712
OKM-C4163-2768-11	L300M	40	1" (INCH)	72	1" (INCH)	50	5006-713
OKM-C4163-2703-11		40	25 (MM)	72	25 (MM)	50	5006-714



Boring Bar Holder



OKUMA TYPE

● External Coolant Supply

NEW

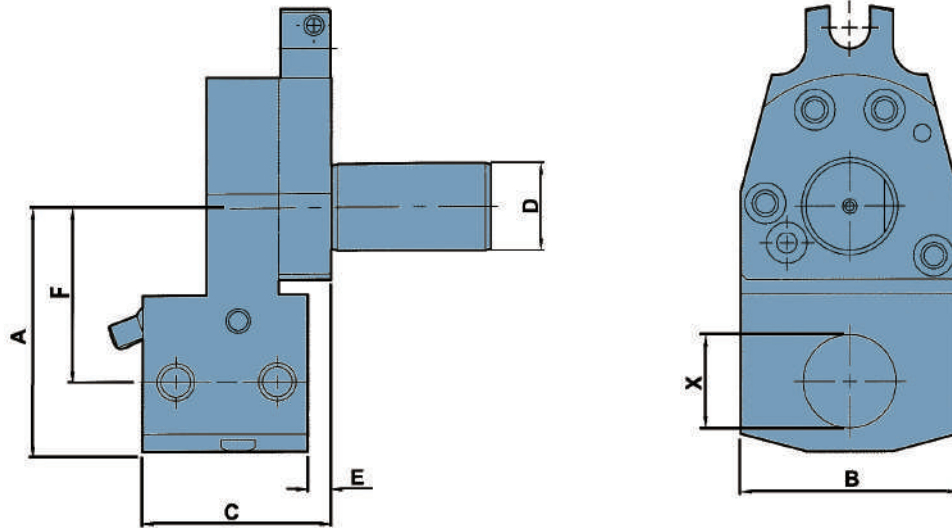

DIMENSIONS

ORDER NO.	OKUMA TYPE	D	X	A	B	C	E	F	CODE NO.
OKM-4167-2611-10	L200M	30	32 (MM)	84	75	65	8	60	5006-720
OKM-4176-2566-10	L300M	40	1.5" (INCH)	135	94	65	-10	110	5006-721
OKM-4163-2707-10		40	40 (MM)	135	94	65	-10	110	5006-722



Boring Bar Holder

● External Coolant Supply

NEW

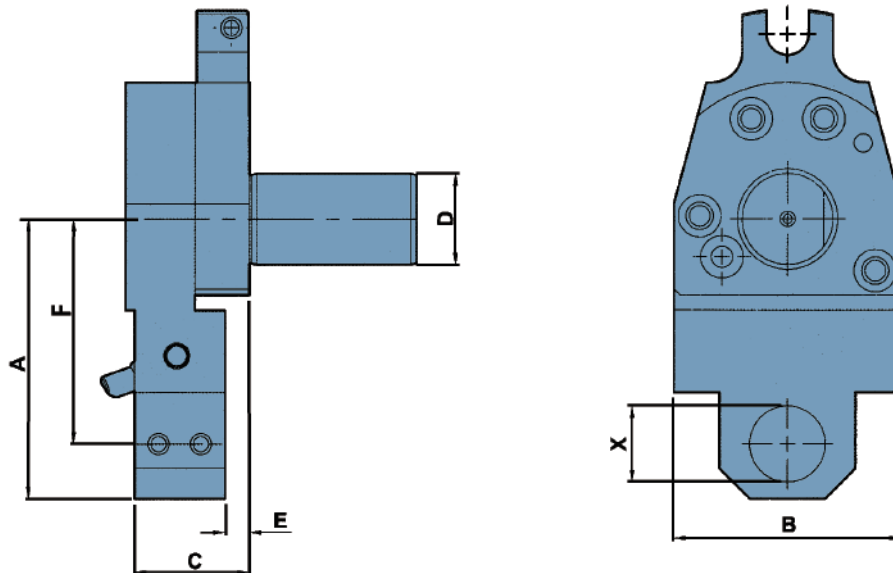

DIMENSIONS

ORDER NO.	OKUMA TYPE	D	X	A	B	C	E	F	CODE NO.
OKM-4167-2612-10	L200M	30	25	92	75	38	8	74	5006-726



NEW



Italian Style

- The main block is assembled with cast-hardened steel, secured rigidly by the latch carriage machine steel bolt.
- The main block has 4 slide openings for inserting the proper tool-holder; these can be securely fastened by a simple and safe eccentric device, which also adjusts the height for each tool holder.
- The tool shank is securely held by 4 hardened screws. The simplicity and fast tool changing increase the production of lathe turning.
- No chatter or vibrations.
- This style is interchangeable with Rapidue and STM.

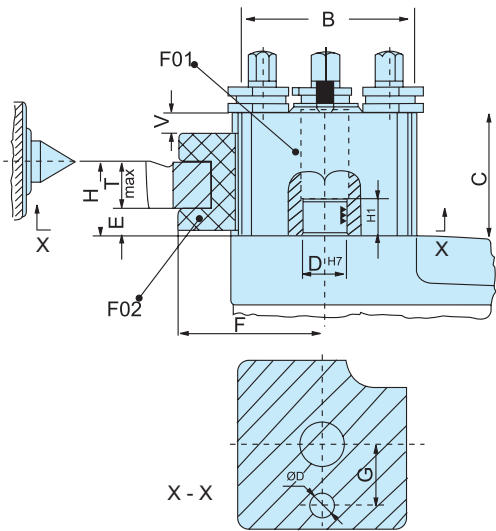

Complete set includes:

- 1 pieces Tool post
- 3 pieces of turning holders
- 1 piece of Round shanks
- Standard spanners

MAIN BODY DIMENSIONS

ORDER NO.	Lathe swing	B	D ^{H7}	H		C	E	T _{max}	F	V _{max}	Ø _{max}	Morse NO.	ØD	G	H1	
				Min	Max											
VTP-M	180-250	57.7	18	24	34	45	8	16	56	10	14	1	7	27	18	70
VTP-AR-AP	250-300	64.5	18	25	41	56	9	16	63	16	16	1	8	30	16	80
VTP-A	250-350	82.0	24	32	42	60	12	20	75	10	18	2	10	35	20	100
VTP-BR-BP	300-380	91.6	28	38	53	75	13	25	90	17	20	3	10	40	20	115
VTP-B	350-500	100.0	30	47	65	85	15	32	100	15	24	3	12	48.2	25	127
VTP-C	500-650	115.3	38	51	72	94	19	32	108	24	26	4	14	58.2	26	145

SET TYPE

ORDER NO.	5-PIECE SETS EACH SET INCLUDES	G.W. kgs	CODE NO.
VTP-M	1 x F01-M, 3 x F02-M AND 1 x F03-M	3.1	5006-890
VTP-AR-AP	1 x F01-AR-AP, 3 x F02-AR-AP AND 1 x F03-AR-AP	4.5	5006-891
VTP-A	1 x F01-A, 3 x F02-A AND 1 x F03-A	9.3	5006-892
VTP-BR-BP	1 x F01-BR-BP, 3 x F02-BR-BP AND 1 x F03-BR-BP	13.2	5006-893
VTP-B	1 x F01-B, 3 x F02-B AND 1 x F03-B	17.5	5006-894
VTP-C	1 x F01-C, 3 x F02-C AND 1 x F03-C	23.0	5006-895

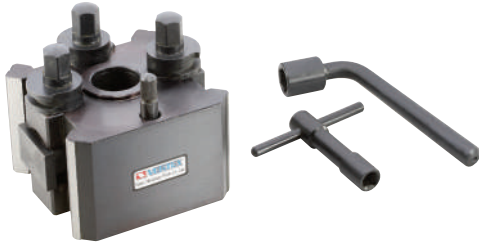

Tool Post

ORDER NO.	Centre Height (mm)	Lathe Swing (mm)	CODE NO.
VTP-F01-M	120	240	5006-900
VTP-F01-AR-AP	140	280	5006-901
VTP-F01-A	170	340	5006-902
VTP-F01-BR-BP	200	400	5006-903
VTP-F01-B	230	460	5006-904
VTP-F01-C	280	560	5006-905

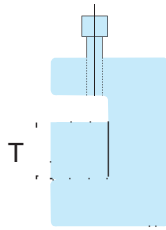

● Turning Holders

Turning Holder

ORDER NO.	Centre Height (mm)	Max. Square & Rectangular Tool (mm)	CODE NO.
VTP-F02-M	120	16	5006-906
VTP-F02-AR-AP	140	16	5006-907
VTP-F02-A	170	20	5006-908
VTP-F02-BR-BP	200	25	5006-909
VTP-F02-B	230	32	5006-910
VTP-F02-C	280	32	5006-911

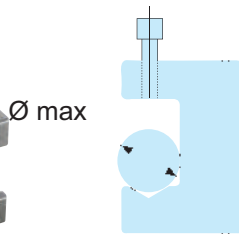

● Round Shanks

Round Shanks

ORDER NO.	Centre Height (mm)	Max. Holding Dia (mm)	CODE NO.
VTP-F03-M	120	14	5006-912
VTP-F03-AR-AP	140	16	5006-913
VTP-F03-A	170	18	5006-914
VTP-F03-BR-BP	200	20	5006-915
VTP-F03-B	230	24	5006-916
VTP-F03-C	280	26	5006-917

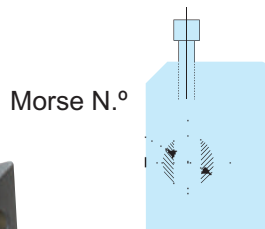

● Morse Holder

Morse Holder

ORDER NO.	Centre Height (mm)	Morse Taper Hole	CODE NO.
VTP-F04-M	120	MT No. 1	5006-918
VTP-F04-AR-AP	140	MT No. 2	5006-919
VTP-F04-A	170	MT No. 2	5006-920
VTP-F04-BR-BP	200	MT No. 3	5006-921
VTP-F04-B	230	MT No. 3	5006-922
VTP-F04-C	280	MT No. 4	5006-923



Quick Change Tool Post & Holders-40

Positioning European Style



NEW

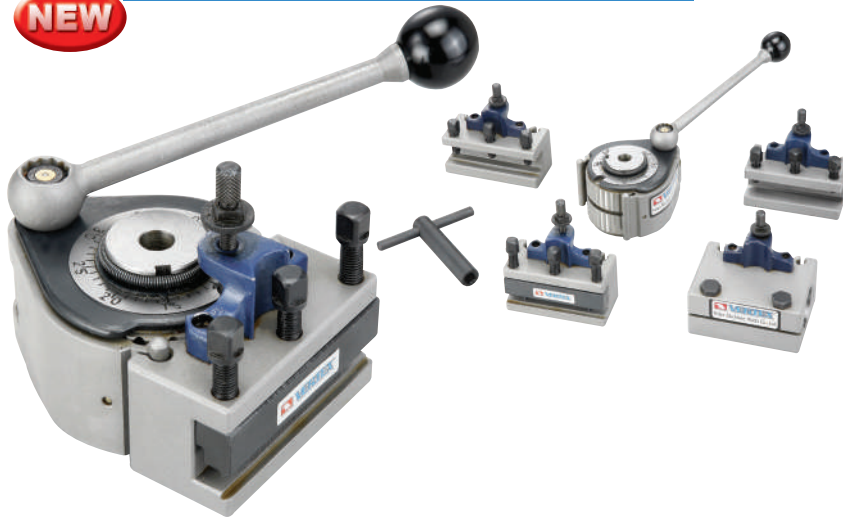

European Style

Tool post and tool holders are precisely grounded with 40 tool-bit positions. Easy to operate and can be fitted with many different tool-holders. Locking and loosening of any tool-holders are performed by a simple eccentric clamping. The simplicity and fast tool changing increases the lathe turning production. A height adjustment for tool bits is controlled by a knurled head-screw, without the need for packing plates or shims. This style is interchangeable with Hasse.

Complete set includes:

- 1 Pieces Tool post
- 3 pieces Turning & Facing Holder-"D"
- 1 piece Boring Bar Holder-"B"

ORDER NO.	5-PIECE SETS EACH SET INCLUDES (5 pcs/set)	G.W. kgs	CODE NO.
VTP-V-A0	1 x tool post F40-0(A0), 2 x F40-010(A0D12x50) and 1 x F40-020(A0B12x50) and 1 x F40-040(A0A2.7x10x50)	1.5	5006-955A
VTP-V-A1	1 x tool post F40-1(A1), 2 x F40-111(A1D16x75) and 1 x F40-140(A1A2.7x10x75) and 1 x F40-121(A1B16x80)	4.0	5006-956A
VTP-V-E5	1 x tool post F40-2(B5), 2 x F40-211(E5D20x100) and 1 x F40-220(E5B30x100) and 1 x F40-240(E5A2.7x10x100)	8.0	5006-957A
VTP-B2	1 x tool post F40-3(B2), 3 x F40-311(B2D25x120) and 1 x F40-320(B2B32x130)	12.3	5006-958
VTP-C3	1 x tool post F40-4(C3), 3 x F40-411(C3D32x150) and 1 x F40-422(C3B40x160)	24.3	5006-959

Set Style For Lathe

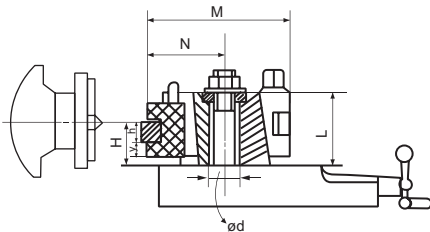

ORDER NO.	VTP-F40-0	VTP-F40-1	VTP-F40-2	VTP-F40-3	VTP-F40-4
	D12	D16 D20	D20 D25	D25 D32	D32 D40 D45
Driving Power (kw)	1.2	2	4.5	7	13
Lathe Swing (mm)	120-220	150-300	200-400	300-500	400-700
H min. (mm)	18.5	25.5 29.5	32 37	38 46	47.5 55.5 61
H max. (mm)	26.5	36.5 40.5	49 52	58 57	87.5 91.5 91
y (mm)	6.5	9.5	12	13 14	15.5 15.5 16
h (mm)	12	16 20	20 25	25 32	32 40 45
M (mm)	6.8	104	132	150	192 201 202
L (mm)	37	55	68	76	107
N (mm)	34	52	66	73	93 102 103
ød (mm)	13	20	20	32	40

40 Position Tool Post Body

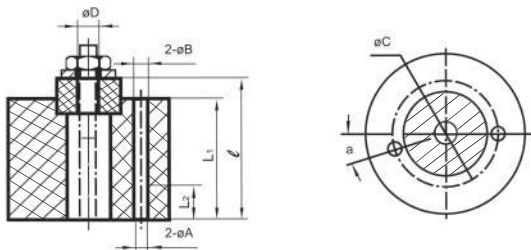

ORDER NO.	ØD	L2	L1	ℓ	ØA	ØB	ØC	α
VTP-F40-0	6	-	30	37	-	-	-	-
VTP-F40-1	10	12	45	55.3	5.6	6.8	42	18°
VTP-F40-2	10	14	57	67.3	5.6	6.8	49	15°
VTP-F40-3	14	20	65	75	6.9	9	64	30°
VTP-F40-4	24.5	10	95	107	9.5	11	88	18°

40 Position Tool Post



ORDER NO.	Lathe swing (mm)	For Style NO.	Height of cutting edge range (mm)	CODE NO.
VTP-F40-0	120-220	VTP-A0	D12/18.5~26.5	5006-930
VTP-F40-1	150-300	VTP-A1	D16/25.5~36.5 or D20/29.5~40.5	5006-931
VTP-F40-2	200-400	VTP-E5	D20/32~49 or D25/37~52	5006-932
VTP-F40-3	300-500	VTP-B2	D25/38~58 or D32/46~57	5006-933
VTP-F40-4	400-700	VTP-C3	D32/47.5~87.5 or D40/55.5~91.5 or D45/61~91	5006-934



Quick Change Tool Post & Holders-40

Positioning European Style



NEW

Turning & Facing Holder

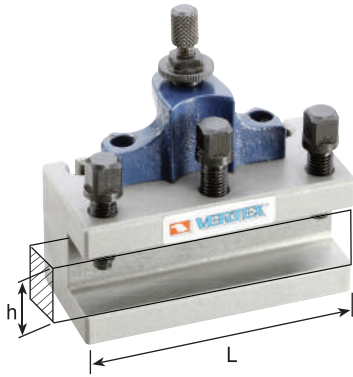

ORDER NO.	Series NO.	Max. Height (mm)	Max. Length (mm)	CODE NO.
VTP-F40-010	A0D	12	50	5006-935
VTP-F40-111	A1D	16	75	5006-936
VTP-F40-112	A1D	16	80	5006-937
VTP-F40-113	A1D	16	90	5006-938
VTP-F40-114	A1D	20	75	5006-939
VTP-F40-110	A1D	20	80	5006-940
VTP-F40-115	A1D	20	90	5006-941
VTP-F40-211	E5D	20	100	5006-942
VTP-F40-212	E5D	25	100	5006-943
VTP-F40-311	B2D	25	120	5006-944
VTP-F40-312	B2D	25	140	5006-945
VTP-F40-313	B2D	32	120	5006-946
VTP-F40-314	B2D	32	140	5006-947
VTP-F40-411	C3D	32	150	5006-948
VTP-F40-412	C3D	32	170	5006-949
VTP-F40-413	C3D	40	150	5006-950
VTP-F40-414	C3D	40	170	5006-951
VTP-F40-415	C3D	45	170	5006-952

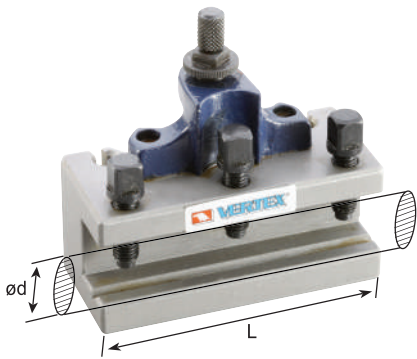

Boring Bar Holder

ORDER NO.	Series NO.	Max. Dia (mm)	Length (mm)	CODE NO.
VTP-F40-020	A0B	12	50	5006-960
VTP-F40-121	A1B	16	80	5006-961
VTP-F40-120	A1B	18	80	5006-962
VTP-F40-122	A1B	20	90	5006-963
VTP-F40-220	E5B	30	100	5006-964
VTP-F40-320	B2B	32	130	5006-965
VTP-F40-421	C3B	32	160	5006-966
VTP-F40-422	C3B	40	160	5006-967

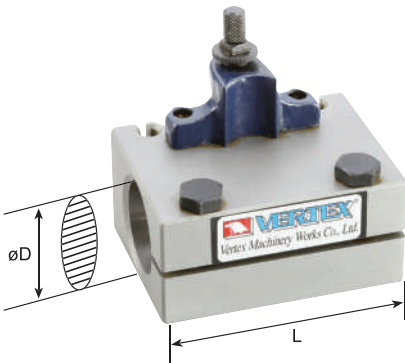

Drilling & Boring Bar Holder

ORDER NO.	Series NO.	Max. Dia (mm)	Length (mm)	CODE NO.
VTP-F40-030	A0S	15	50	5006-968
VTP-F40-130	A1S	30	80	5006-969
VTP-F40-131	A1S	20	90	5006-970
VTP-F40-231	E5S	30	100	5006-971
VTP-F40-232	E5S	40	100	5006-972
VTP-F40-330	B2S	40	120	5006-973
VTP-F40-431	C3S	40	150	5006-974
VTP-F40-432	C3S	50	150	5006-975



Cut-Off Tool Holder

ORDER NO.	Series NO.	Blade- TxW	Length (mm)	CODE NO.
VTP-F40-040	A0A	2.7 x 10	50	5006-976
VTP-F40-140	A1A	2.7 x 10	75	5006-977
VTP-F40-240	E5A	2.7 x 10	100	5006-978
VTP-F40-340	B2A	4 x 16	120	5006-979
VTP-F40-440	C3A	5 x 18.5	150	5006-980

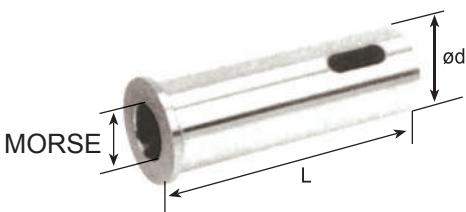

Morse Taper Bushing

ORDER NO.	Series NO.	Diameter (mm)	Length (mm)	Morse Taper	CODE NO.
VTP-F40-151	A1L	30	80	NO.1	5006-981
VTP-F40-152	A1L	30	90	NO.2	5006-982
VTP-F40-251	E5L	30	96	NO.2	5006-983
VTP-F40-252	E5L	40	114	NO.3	5006-984
VTP-F40-350	E5L	40	120	NO.2	5006-985
VTP-F40-351	E5L	40	120	NO.3	5006-986
VTP-F40-451	C3L	40	140	NO.3	5006-987
VTP-F40-452	C3L	40	150	NO.4	5006-988
VTP-F40-453	C3L	50	150	NO.4	5006-989

TOOL POST



Quick Change Tool Post American Type



- For conventional lathe.
- The height of the post unit can be adjusted to desire position & center line.
- Can choose set type or separated holders.
- Harden & precise positions.

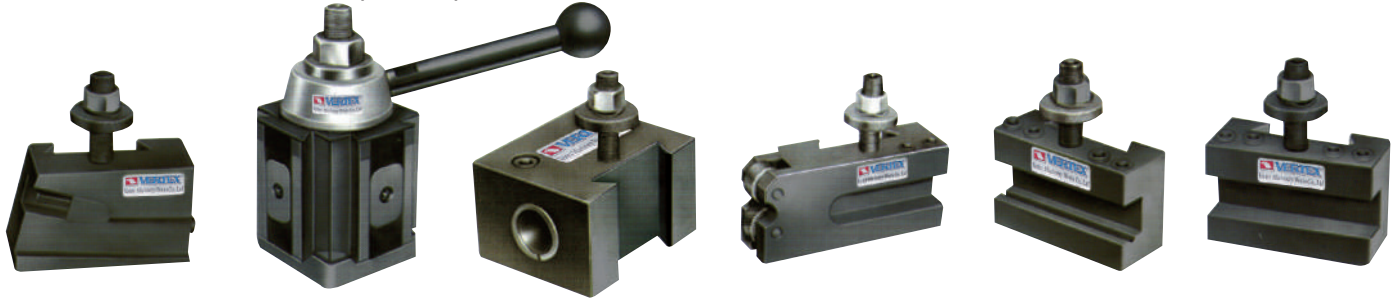

PISTON TYPE SETS VTP-□□□□P TYPE
BODY WITH 6 PCS HOLDER

PISTON STYLE TOOL POST SETS

ORDER NO.	LATHE SWING	6-PIECE SETS EACH SET INCLUDES (6PCS/SET)	N. W. KGS	CODE NO.
VTP-0012P	12"	1 xF50-100, 1 xF50-101, 1 xF50-102 1 xF50-104, 1 xF50-107, 1 xF50-110 EACH 1PCS	5.5	5006-1101
VTP-1015P	10"-15"	1 xF50-200, 1 xF50-201, 1 xF50-202 1 xF50-204, 1 xF50-207, 1 xF50-210 EACH 1PCS	8	5006-1102
VTP-1318P	13"-18"	1 xF50-300, 1 xF50-301, 1 xF50-302 1 xF50-304, 1 xF50-307, 1 xF50-310 EACH 1PCS	11.5	5006-1103
VTP-1420P	14"-20"	1 xF50-400, 1 xF50-401, 1 xF50-402 1 xF50-404, 1 xF50-407, 1 xF50-410 EACH 1PCS	21	5006-1104

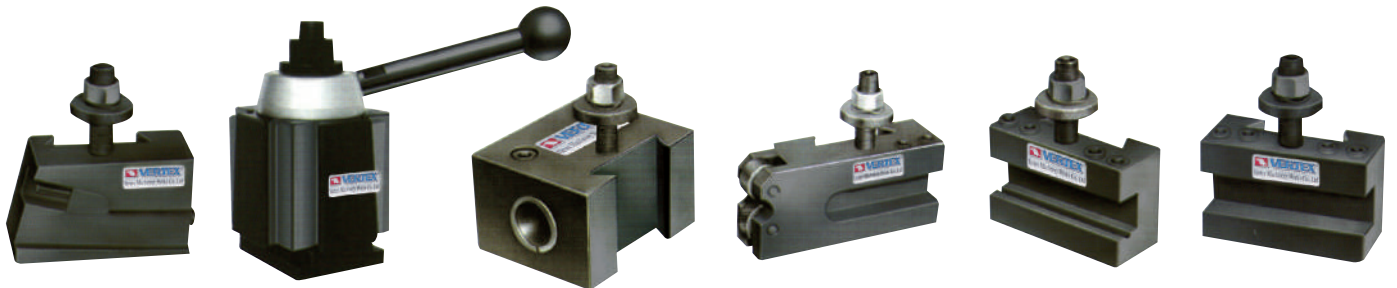

WEDGE TYPE SETS VTP-□□□□W TYPE
BODY WITH 6 PCS HOLDER

WEDGE STYLE TOOL POST SETS

ORDER NO.	LATHE SWING	6-PIECE SETS EACH SET INCLUDES (6PCS/SET)	N. W. KGS	CODE NO.
VTP-0012W	12"	1 xF50-111, 1 xF50-101, 1 xF50-102 1 xF50-104, 1 xF50-107, 1 xF50-110 EACH 1PCS	5.5	5006-1121
VTP-1015W	10"-15"	1 xF50-222, 1 xF50-201, 1 xF50-202 1 xF50-204, 1 xF50-207, 1 xF50-210 EACH 1PCS	8.0	5006-1122
VTP-1318W	13"-18"	1 xF50-333, 1 xF50-301, 1 xF50-302 1 xF50-304, 1 xF50-307, 1 xF50-310 EACH 1PCS	12.8	5006-1123
VTP-1420W	14"-20"	1 xF50-444, 1 xF50-401, 1 xF50-402 1 xF50-404, 1 xF50-407, 1 xF50-410 EACH 1PCS	21.0	5006-1124
VTP-1748W	17"-48"	1 xF50-555, 1 xF50-501, 1 xF50-502 1 xF50-504, 1 xF50-507, 1 xF50-510 EACH 1PCS	40.0	5006-1125

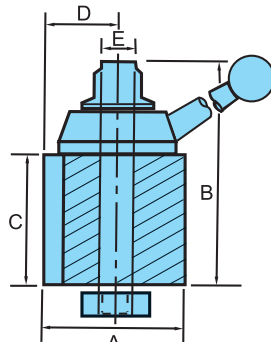

QUICK CHANGE TOOL POST PISTON STYLE-ACCESSORIES

ORDER NO.	SWING FOR LATHE		A		B		C		D		E	CODE NO.
	INCH	MERTIC	INCH	MERTIC	INCH	MERTIC	INCH	MERTIC	INCH	MERTIC		
VTP-F50-1	12	304	2 1/2	63.5	3 3/4	95.25	2 1/4	57.15	1 7/16	36.512	M14X1.5	5006-1131
VTP-F50-2	10-15	255-380	3	76.2	4 3/8	111.125	2 3/4	69.85	1 5/8	41.275	M16X1.5	5006-1132
VTP-F50-3	13-18	330-455	3 3/8	85.725	4 7/8	123.825	3	76.2	1 7/8	47.625	M20X2	5006-1133
VTP-F50-4	14-20	355-505	4	101.6	6	152.4	3 5/8	92.075	2 1/8	53.975	M20X2	5006-1134



Quick Change Tool Post American Type



NEW

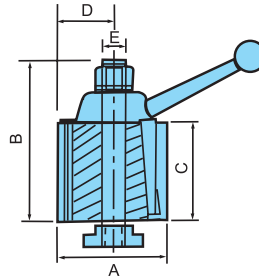

QUICK CHANGE TOOL POST WEDGE STYLE

ORDER NO.	SWING FOR LATHE		A		B		C		D		E	CODE NO.
	INCH	MERTIC	INCH	MERTIC	INCH	MERTIC	INCH	MERTIC	INCH	MERTIC		
VTP-F50-11	12	304	2 1/2	63.5	3 3/4	95.25	2 1/4	57.15	1 3/8	34.925	M14X1.5	5006-1141
VTP-F50-22	10-15	255-380	3	76.2	4 3/8	111.125	2 3/4	69.85	1 9/16	39.68	M16X1.5	5006-1142
VTP-F50-33	13-18	330-455	3 1/2	88.9	4 7/8	123.83	3	76.2	1 29/32	48.42	M20X2	5006-1143
VTP-F50-44	14-20	355-505	4	101.6	6	152.4	3 5/8	92.075	2 1/8	53.975	M22X2	5006-1144
VTP-F50-55	17-48	435-1215	5	127	7 3/8	187.32	4 5/8	117.47	2 11/16	68.26	M24X2	5006-1145

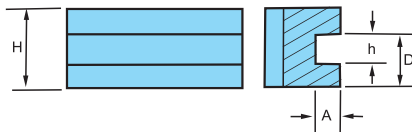

TURNING AND FACING HOLDER



ORDER NO.	A		D		H		h		CODE NO.
	INCH	MERTIC	INCH	MERTIC	INCH	MERTIC	INCH	MERTIC	
VTP-F50-101	7/16	11.11	15/16	23.81	1 1/2	38.1	1/2	12.7	5006-1151
VTP-F50-201	1/2	12.7	1 1/8	28.57	1 3/4	44.45	5/8	15.87	5006-1152
VTP-F50-301	5/8	15.87	1 7/16	36.51	2 1/8	53.97	3/4	19.05	5006-1153
VTP-F50-401	3/4	19.05	1 11/16	42.86	2 1/2	63.5	1	25.4	5006-1154
VTP-F50-501	1	25.4	3 3/16	55.56	3 1/8	79.37	1 1/4	31.75	5006-1155

Suitable for any size smaller than max. Height h.

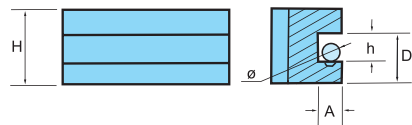

BORING, TURNING AND FACING HOLDER



ORDER NO.	A		D		H		h		Ø		CODE NO.
	INCH	MERTIC	INCH	MERTIC	INCH	MERTIC	INCH	MERTIC	INCH	MERTIC	
VTP-F50-102	7/16	11.11	15/16	23.81	1 1/2	38.1	1/2	12.7	7/16	11.11	5006-1161
VTP-F50-202	1/2	12.7	1 1/8	28.57	1 3/4	44.45	5/8	15.87	1/2	12.7	5006-1162
VTP-F50-302	5/8	15.87	1 7/16	36.51	2 1/8	53.97	3/4	19.05	5/8	15.87	5006-1163
VTP-F50-402	3/4	19.05	1 11/16	42.86	2 1/2	63.5	1	25.4	3/4	19.05	5006-1164
VTP-F50-502	1	25.4	3 3/16	55.56	3 1/8	79.37	1 1/4	31.75	1 1/8	28.57	5006-1165

Suitable for square and round shank & boring bars.

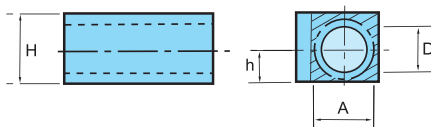

• Split bushing suitable for small boring bars & drill.

HEAVY DUTY BORING BAR HOLDER



ORDER NO.	A		D		H		h		CODE NO.
	INCH	MERTIC	INCH	MERTIC	INCH	MERTIC	INCH	MERTIC	
VTP-F50-104	3/4	19.05	5/8	15.87	1 1/2	38.1	3/4	19.05	5006-1171
VTP-F50-204	1	25.4	3/4	19.05	1 3/4	44.45	7/8	22.22	5006-1172
VTP-F50-304	1	25.4	3/4	19.05	2	50.8	1	25.4	5006-1173
VTP-F50-404	1 1/4	31.75	1	25.4	2 1/2	63.5	1 1/4	31.75	5006-1174
VTP-F50-504	1 1/2	38.1	1 1/4	31.75	3 1/8	79.37	1 9/16	39.68	5006-1175
VTP-F50-141	1	25.4	3/4	19.05	1 3/4	44.45	7/8	22.22	5006-1176
VTP-F50-241	1 1/4	31.75	1	25.4	2	50.8	1	25.4	5006-1177
VTP-F50-341	1 1/4	31.75	1	25.4	2 1/4	57.15	1 1/8	28.57	5006-1178
VTP-F50-441	1 1/2	31.75	1 1/4	25.4	2 3/4	57.15	1 3/8	28.75	5006-1179



Quick Change Tool Post American Type

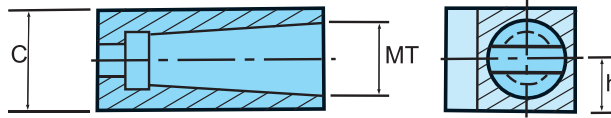

MORSE TAPER HOLDER FOR DRILLING

ORDER NO.	C		h		M.T	CODE NO.
	INCH	MERTIC	INCH	MERTIC		
VTP-F50-105	1 1/2	38.1	3/4	19.5	2	5006-1191
VTP-F50-205	1 3/4	44.45	7/8	22.225	2	5006-1192
VTP-F50-305	2	50.8	1	25.4	3	5006-1193
VTP-F50-405	2 1/2	63.5	1 1/4	31.75	3	5006-1194
VTP-F50-153	1 1/2	38.1	3/4	19.05	3	5006-1195
VTP-F50-253	1 3/4	44.45	7/8	22.22	3	5006-1196
VTP-F50-353	2 1/8	53.97	1 1/16	26.98	4	5006-1197
VTP-F50-453	2 3/8	60.32	1 3/16	30.16	4	5006-1198

Allows to install a dead center serve as a tail stock.
Suitable for drilling & boring & reaming.

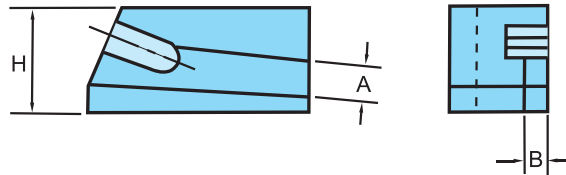

UNIVERSAL PARTING BLADE TOOL HOLDER

ORDER NO.	A		B		H		CODE NO.
	INCH	MERTIC	INCH	MERTIC	INCH	MERTIC	
VTP-F50-107	1/2	12.7	3/16	4.76	1 1/2	38.1	5006-1211
VTP-F50-207	11/16	17.46	3/16	4.76	1 3/4	44.45	5006-1212
VTP-F50-307	3/4	19.05	3/16	4.76	2	50.8	5006-1213
VTP-F50-407	7/8	22.23	1/4	6.35	2 1/2	63.5	5006-1214
VTP-F50-507	1 3/16	30.16	1/4	6.35	2 3/4	69.85	5006-1215

Suitable for cutting tool.

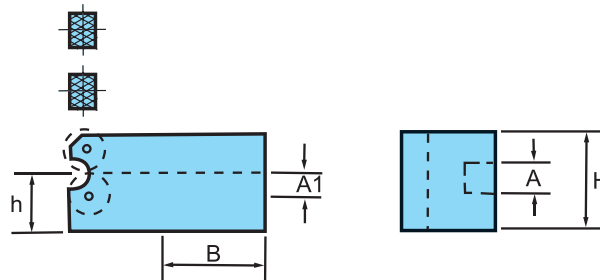

KNURLING, TURNING & FACING HOLDER

ORDER NO.	A		A1		B		H		h		CODE NO.
	INCH	MERTIC	INCH	MERTIC	INCH	MERTIC	INCH	MERTIC	INCH	MERTIC	
VTP-F50-110	1/2	12.7	3/8	9.53	2 1/2	63.5	1 9/16	39.68	7/8	22.22	5006-1221
VTP-F50-210	5/8	15.87	1/2	12.7	2 5/8	66.67	1 3/4	44.45	1	25.4	5006-1222
VTP-F50-310	3/4	19.05	1/2	12.7	3 1/8	79.37	2	50.8	1 3/16	30.16	5006-1223
VTP-F50-410	1	25.4	3/4	19.05	3 3/4	95.25	2 1/2	63.5	1 7/16	36.51	5006-1224
VTP-F50-510	1 1/4	31.75	1	25.4	4 1/2	114.3	3 1/8	79.37	1 7/8	47.62	5006-1225

Suitable for knurling, facing & boring.