



Shock Absorber

G01 Shock Absorber



TK-90, 120, 160, 200

G01 Shock Absorber



SB-4, 6, 8, 10

G01 Shock Absorber



SC-1, 2, 3

G01 Shock Absorber



SY-8, 12, 16

G02 Shock Absorber



VSA-25K

G02 Shock Absorber



VSA-35K, VSA-35K-6RU

G02 Shock Absorber



VSA-35K-PS, VSA-35-PS-BL

G03 Shock Absorber



VSA-150H

G03 Shock Absorber



VSA-150K

G03 Shock Absorber



VSA-150H

Slide Table

G03 Arbor Press



VAR-0, 1, 2, 3, 5

G03 Arbor Press



VARR-3, 5

G04 One Way Acme Thread Slide Table



ST-75, 100, 125

G04 One Way Acme Thread Slide Table



STA-160, 165, 200, 205, 300

G04 Vertical Dovetail Slide Table



SE-100, 150, 200, 250

G05 Precision Boring/ Mining Spindle Head

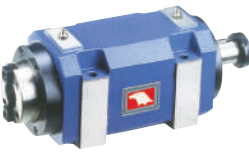

SH03, 04, 30, 40, 50

G05 Precision Boring/ Mining Spindle Head



SH03, 04, 30, 40, 50

G05 Precision Boring/ Mining Spindle Head



SH03, 04, 30, 40, 50

G05 Precision Boring/ Mining Spindle Head



SH30A, 30B, 40A, 40B

G05 Precision Boring/ Mining Spindle Head



SH30A, 30B, 40A, 40B

Handle System

G06 Flat End Movable Handle



VFE-10, 83, 8, 165

G06 Ellipse Movable Handle



VEM-10, 83, 8, 6

G06 Ball Knobs

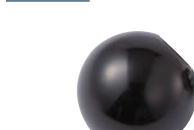

VKB-6AA ~ 12BA

G06 Hand Knobs



VKB-8K, 8KL

G07 Adjustable Hand Levers



VAH-6, 8, 10, 12

G07 Adjustable Hand Levers



VAH-620 ~ 1020

G07 Revolving Handles



VRL-8H, 8HA, 10H, 10HA, 10HB

G07 360° Swivelling Lock Handle



VSA-1 ~ 4, VSB-1 ~ 4

G08 Crank Handle



VAH-21~23, 31~32

G08 Shoulder Bolt



VLS-1320~1840

G08 Washer



VLE-W226~W3515

G08 Lifting Eye Bolts



VLE-6A ~ 24A

G09 Ball Plugger Screw-socket & Slotted

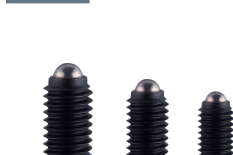

VBP-031 ~ 16I, VBP-03H ~ 16H

G10 PU-Hammer Series



VHM-38, 46, 50, 58, 60

G10 Hammer



VHM-25PE ~ 60PE



Sawing Machine

G11 Universal Drill & Cutter Grinder



VDG-32N

G11 Horizontal Band Saws



HBS-7

G12 Horizontal Band Saws



HBS-7CE

G12 Saw Blade



HBS-106 ~

G12 Saw Blade



HBS-106 ~

Air Die Tool System

G13 Air Die Tool



VAG-500, 601A

G13 Air Die Tool



VAG-500, 601A

G13 Air Die Tool



VAG-701

G13 Air Die Tool



VAG-609

G13 Air Die Tool



VAG-8241

G14 Air Die Tool



VAG-604

G14 Air Die Tool



VAG-605

G14 Air Die Tool



VAG-8242

G14 Air Die Tool



VAG-932

G15 Air Die Tool



VAG-318

G15 Air Die Tool



VAG-F30

G15 Air Die Tool



VAG-310

G15 Air Die Tool



VAG-320

G16 Air Die Tool



VAG-030

G16 Air Die Tool



VAG-050

G16 Air Die Tool



VAG-070

G16 Air Die Tool



VAG-070H





Air Die Tool

G17 Abrasive Mounted Point & Wheel For Air Tool



WA-303A ~ 310A

G17 Abrasive Mounted Point & Wheel For Air Tool



WA-303A ~ 310A

G17 Abrasive Mounted Point & Wheel For Air Tool

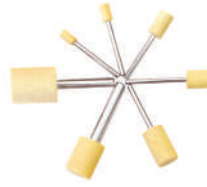

WF-304 ~ 312

G17 Abrasive Mounted Point & Wheel For Air Tool



WF-304 ~ 312

G17 Abrasive Mounted Point & Wheel For Air Tool



WR-304 ~ 310

G17 Abrasive Mounted Point & Wheel For Air Tool



WR-304 ~ 310

G17 Abrasive Mounted Point & Wheel For Air Tool



WE-303 ~ 310

G17 Abrasive Mounted Point & Wheel For Air Tool



WE-303 ~ 310

G17 Abrasive Mounted Point & Wheel For Air Tool



WF-30P

G17 Abrasive Mounted Point & Wheel For Air Tool



WF-30S

G17 Abrasive Mounted Point & Wheel For Air Tool



WF-30C

G17 Handy Sponge Saner



VSS-436

G17 Handy Sponge Saner

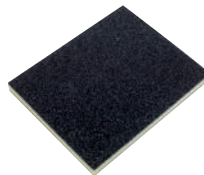

VSS-560

G18 Diamond Tools For Air Tool



WG-30D

G18 Diamond Tools For Air Tool



WG-30D

Carbide Burrs

G19 Carbide Rotary Burrs

NEW



VRB-C6, C8, C10, C12

G19 Carbide Rotary Burrs

NEW



VRB-C6, C8, C10, C12

G19 Carbide Rotary Burrs

NEW



VRB-S6, S8, S10, S12

G19 Carbide Rotary Burrs

NEW



VRB-S6, S8, S10, S12

G19 Carbide Rotary Burrs

NEW



VRB-A6, A8, A10, A12

G19 Carbide Rotary Burrs

NEW



VRB-A6, A8, A10, A12

G20 Carbide Rotary Burrs

NEW



VRB-P6, P8, P10, P12

G20 Carbide Rotary Burrs

NEW



VRB-P6, P8, P10, P12

G20 Carbide Rotary Burrs

NEW



VRB-CR6, CR8, CR10, CR12

G20 Carbide Rotary Burrs

NEW



VRB-CR6, CR8, CR10, CR12

G20 Carbide Rotary Burrs



VRB-PC6, PC8, PC10, PC12

G20 Carbide Rotary Burrs



VRB-PC6, PC8, PC10, PC12

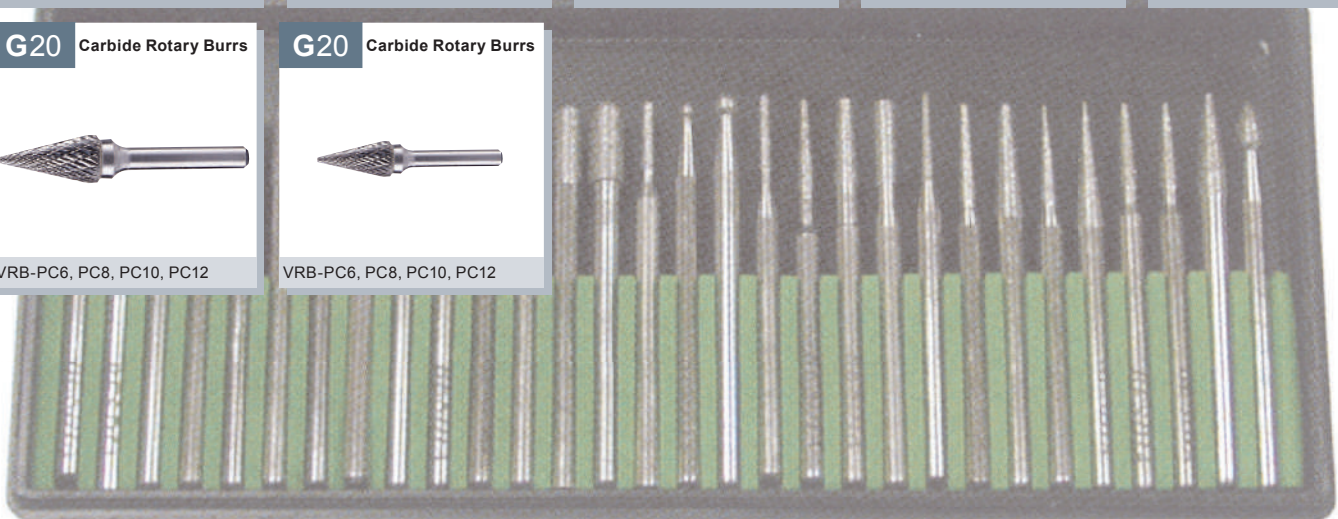

## STANDARD TYPE

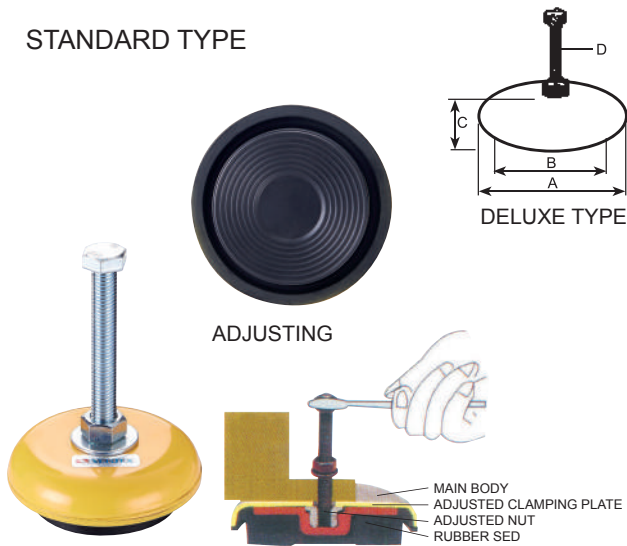

## Special Features

Preventing shock & reducing noise. low bed design.  
Easy installation. Simple adjustment. High durability.

## Application

Various general working machines, metal work piece processing machine, production machine, special machine, measuring equipment, testing machine.  
Electrical generator, air compressor, etc.  
ADJUSTABLE RANGE 6-12 mm

Unit:mm

ORDER NO.	A	B	C	Ø DxL	LOAD KGS	Adjustable HEIGH	WEIGHT KGS	CODE NO.
TK-90	90	50	32	12M-100	500kg	5 mm	0.8	7001-000
TK-120	120	90	35	12M-100	1000kg	5 mm	1.4	7001-001
TK-160	160	130	38	16M-110	1500kg	6 mm	2.8	7001-002
TK-200	200	170	45	20M-120	3500kg	6 mm	4.4	7001-003

Features : Easy to operate. shock-absorbent, reduces machine noise includes adjustment, and assures production accuracy.

## DELUXE TYPE

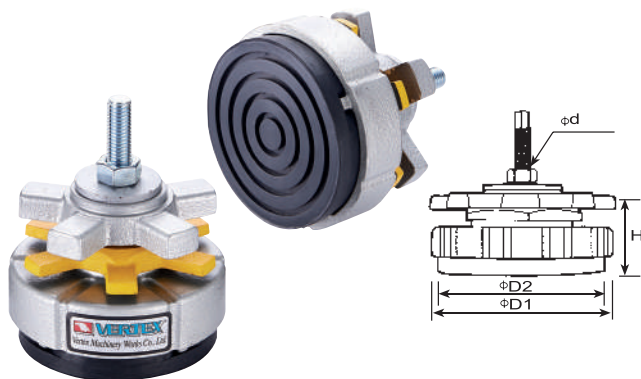

Unit:mm

ORDER NO.	D1	D2	H	Ø dxL	LOAD KGS	Adjustable HEIGH	N.W. KGS	CODE NO.
SB-4	100	90	60	12x50	500	25	2	7001-031
SB-6	150	135	95	16x110	1000	40	5	7001-032
SB-8	200	180	100	20x120	2500	40	8	7001-033
SB-10	250	230	125	24x180	4000	40	12	7001-034

SUITABLE FOR : machine tools, molding machine, printing machine, CNC lathe, grinding machines, drilling machines, milling machines.

- FCD45

## HEAVY DUTY TYPE

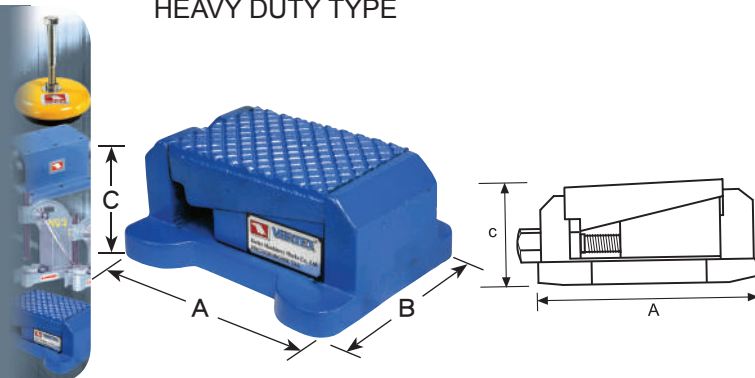

Unit:mm

ORDER NO.	A	B	C	LOAD KGS	Adjustable HEIGH	N.W. KGS	CODE NO.
SC-1	130	96	66	700	4MM	4	7001-060
SC-2	174	143	80	1500	5MM	8.8	7001-061
SC-3	217	165	101	2500	6MM	16	7001-062

SUITABLE FOR : CNC lathe, milling machines, cutting machines, grinding machines.

- FCD45

## LIGHT DUTY TYPE

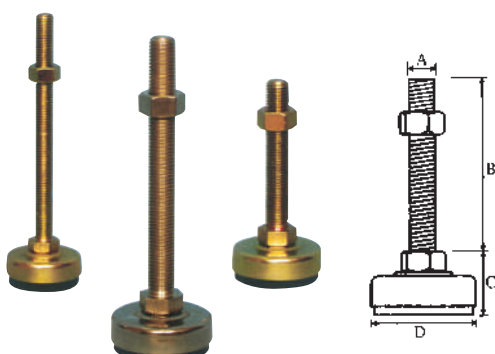

Unit:mm

ORDER NO.	A	B	C	D	LOAD KGS	N.W. KGS	CODE NO.
SY-8	M8X1.25P	50	20	40	100	0.1	7001-080
SY-12	M12X1.25P	75	30	50	200	0.28	7001-081
SY-16	M16X2.0P	100	35	60	300	0.48	7001-082

- SS41

**NEW**

FRON 20 KN TO 225 KN

Machine Stand

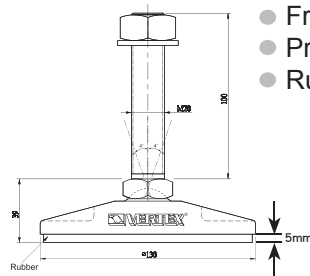

- Leveling
- Reduce Vibration
- Increase Stability
- Frictionless
- Precision & Accurate
- Rubber : 80°, 5mm Thickness

**STEP**

- Place shock absorbers under machine.
- When shock absorbers have full contact with machine base, you can start to adjust the leveling.

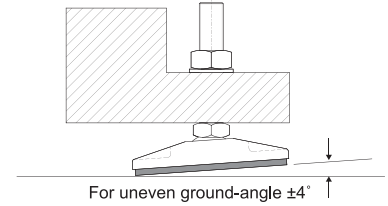
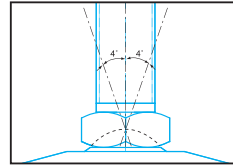

ORDER NO.	L x W x H	THREAD	LOAD KGS	UNEVEN GROUND-ANGLE	WEIGHT KGS	CODE NO.
VSA-25K	130 x 39 x 139	M20 x 100L	2200	± 4°	1.76	7001-140

**NEW**



VSA-35K-6RU

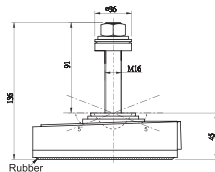

- Leveling
- Reduce Vibration
- Increase Stability
- Frictionless
- Precision & Accurate

**STEP**

- Place shock absorbers under machine.
- When shock absorbers have full contact with machine base, you can start to adjust the leveling.

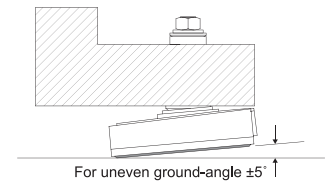
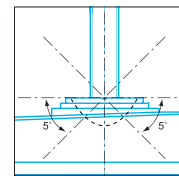
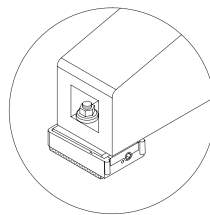

VSA-35K



Adjustable screw

ORDER NO.	L x W x H	THREAD	LOAD KGS	UNEVEN GROUND ANGLE	RUBBER	ADJUSTMENT HEIGHT / FROM ADJUSTABLE SCREW	WEIGHT KGS	CODE NO.
VSA-35K	145 x 95 x 136	M16 x 91L	6300	±5°	2 m/m x 80° shore	7 mm	1.61	7001-160
VSA-35K-6RU	145 x 95 x 140	M16 x 91L	6300	±5°	6 m/m x 90° shore	7 mm	1.61	7001-161

**NEW**



VSA-35K-PS-BL



VSA-35K-PS



ORDER NO.	L x W x H	ADJ. THREAD LENGTH	LOAD KGS	UNEVEN GROUND ANGLE	RUBBER	ADJUSTMENT HEIGHT / FROM ADJUSTABLE SCREW	WEIGHT KGS	CODE NO.
VSA-35K-PS	145 x 95 x 134	M16 x 91L	6300	±5°		7 mm	1.4	7001-162
VSA-35K-PS-BL	145 x 95 x 144	M16 x 81L	6300	±5°		7 mm	1.4	7001-163

SPECIAL USAGE MACHINE



# Shock Absorber Heavy Duty



**NEW**

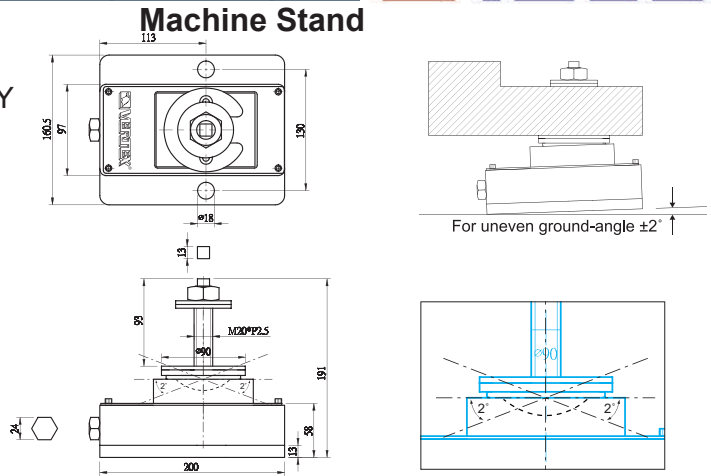

- Leveling
- Reduce Vibration
- Increase Stability
- Frictionless
- Precision & Accurate

### STEP

- Place shock absorbers under machine.
- When shock absorbers have full contact with machine base, you can start to adjust the leveling.

ORDER NO.	L x W x H	THREAD	LOAD KGS	UNEVEN GROUND-ANGLE	ADJUSTMENT HEIGHT / FROM ADJUSTABLE SCREW	WEIGHT KGS	CODE NO.
VSA-150K	200 x 160.5 x 91	M20 x 93L	22500	$\pm 2^\circ$	7 mm	9.32	7001-180
VSA-150H	200 x 160.5 x 182	M20 x 84L	22500	$\pm 2^\circ$	7 mm	9.32	7001-190



# Arbor Press

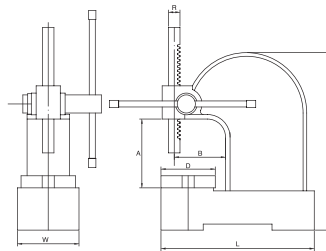

### STANDARD TYPE

- All main parts made of ductile cast iron. Adjustable handle gives convenient handle positioning.
- Ram finite control by smooth gears.
- 4-90 degree equally divided slotted round table.
- Color may vary. (Green)

ORDER NO.	Base LxW(mm)	Height H(mm)	MAX Work Height A(mm) Stroke	Swing B	Table Diameter D	Ram Dimension RxR	Weight (kgs)	CODE NO.
VAR-0	235x102mm	254	114	85	90	19x19	8.5	7002-100
VAR-1	270x127mm	320	140	105	110	25.4x25.4	12	7002-101
VAR-2	400x170mm	445	215	135	170	31.7x31.7	29	7002-102
VAR-3	470x200mm	570	317	135	170	38.1x38.1	47	7002-103
VAR-5	680x250mm	800	470	245	250	50.8x50.8	140	7002-104

### RATCHET LEVERS TYPE

This arbor press with all standard's feature. But operated with a ratchet device that will allow you to use the lever in the most convenient position, the lever has a counterweight for quick return after which the down stroke handwheel will return the ram to the work quickly.

- Ratchet Type Arbor Press available-No. 3/5 only. The size is same as VAR-3, 5 Color may be varied. (Green)



ORDER NO.	VARR-3	VARR-5
G.W. KGS	65 kgs	162 kgs
CODE NO.	7002-131	7002-132



# One Way Acme Thread Slide Table

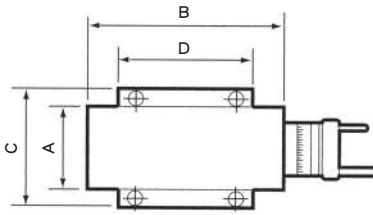

- Material : FC-30
- Precision :  $\pm 0.01 / 100\text{mm}$

ST-75 ST-100 ST-125

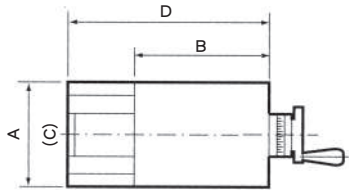
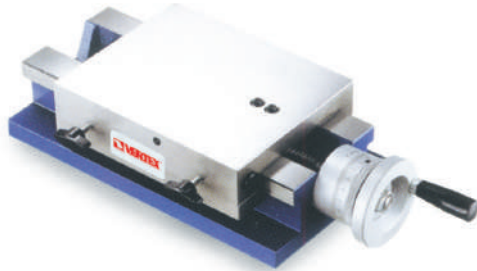

- Material : FC-30
- Precision :  $\pm 0.01 / 100\text{mm}$
- FEATURE : The sliding surfaces are treated by heat-treatment & precision ground.

STA-160 STA-165 STA-200  
STA-205 STA-300 STA-305

## Specifications

Unit: mm

ORDER NO.	A x B Table surface	C x D Base area	Stroke	Total height	Dial graduation	WEIGHT kgs	CODE NO.
ST-75	75 x 180	105 x 157	75	60	2.5 x 0.02	6.5	7002-540
ST-100	100 x 235	140 x 160	100	70	2.5 x 0.02	9.5	7002-541
ST-125	125 x 300	165 x 255	125	80	4.0 x 0.02	18.5	7002-542
STA-160	160 x 200	160 x 300	100	90	4.0 x 0.02	20	7002-543
STA-165	160 x 200	160 x 400	200	90	4.0 x 0.02	23.0	7002-544
STA-200	200 x 300	200 x 400	100	120	4.0 x 0.02	38.0	7002-545
STA-205	200 x 300	200 x 600	300	120	4.0 x 0.02	50.5	7002-546
STA-300	300 x 350	300 x 500	150	188	4.0 x 0.02	98.0	7002-547



# Vertical Dovetail Slide Table

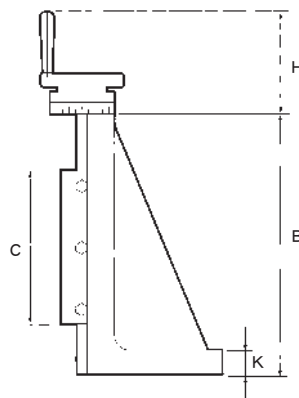

- Material : FC-30
- Precision :  $\pm 0.01 / 100\text{mm}$
- FEATURE : The sliding surfaces are treated by heat-treatment & precision ground  
Dial graduation 4.0 x 0.02mm

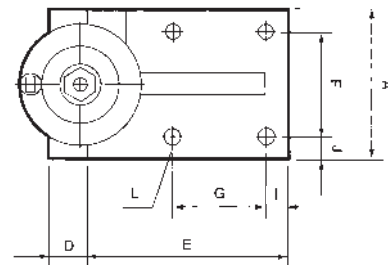

## Specifications

Unit: mm

ORDER NO.	A	B	C	D	E	F	G	H	I	J	K	L	Weight kgs	CODE NO.
SE-100	100	255	150	35	130	70	60	120	30	15	26	Ø10 x 4	15	7002-560
SE-150	150	385	200	40	185	110	90	120	20	20	35	Ø13 x 4	35	7002-561
SE-200	200	510	250	60	240	160	140	135	20	20	40	Ø17 x 4	67	7002-562
SE-250	250	600	300	60	280	200	160	140	25	25	40	Ø17 x 4	115	7002-563

SPECIAL USAGE MACHINE

# Precision Boring/Milling Spindle Head VERTEX®

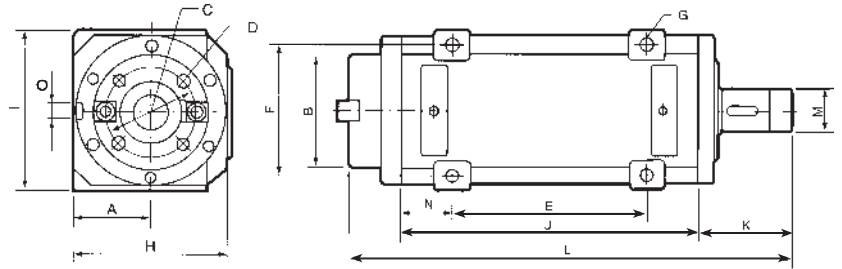

## Specifications

Unit: mm

ORDER NO.	Taper	MAX. R.P.M.	A	B	C	D	E	F	G	H	I	J	K	L	M	N	O	Weight kgs	Bearing O.D.	CODE NO.
SH03	MT3	7000	45	Ø42			80	70	Ø9-4	90	90	160	75	270	Ø25	35	16x5	8	Ø62 Ø55	7002-600
SH04	MT4	2500	70	Ø88.882			190	90	Ø15-4	145	150	280	94	427	Ø35	45	16x5	36	Ø90	7002-601
SH30	NT30	3000	55	Ø69.832	Ø54	M10xP1.5-4	120	90	Ø11-4	114	114	200	72	317	Ø30	40	16x5	18	Ø75	7002-603
SH40	NT40	2500	70	Ø88.882	Ø66.7	M12xP1.75-4	190	150	Ø15-4	170	184	280	106	427	Ø35	45	16x5	39	Ø90	7002-605
SH50	NT50	2000	85	Ø128.57	Ø101.6	M16xP2.0-4	220	150	Ø15-4	170	184	340	106	500	Ø50	60		75	Ø115	7002-607

# Precision Boring/Milling Spindle Head

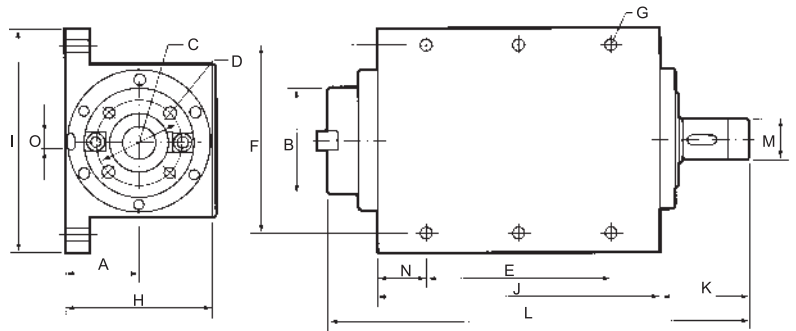

## Specifications

Unit: mm

ORDER NO.	Taper	MAX. R.P.M.	A	B	C	D	E	F	G	H	I	J	K	L	M	N	O	Weight kgs	Bearing O.D.	CODE NO.
SH30A	NT30	3000	77	Ø69.832	Ø54	M10xP1.5-4	160	140	Ø11-6	133	176	200	72	317	Ø30	10	16x5	22	Ø75	7002-620
SH30B	NT30	9000	77	Ø69.832	Ø54	M10xP1.5-4	160	140	Ø11-6	133	176	200	72	317	Ø30	10	16x5	22	Ø75	7002-621
SH40A	NT40	2500	77	Ø88.882	Ø66.7	M12xP1.75-4	180	170	Ø11-6	147	200	220	94	367	Ø35	20	16x5	45	Ø90	7002-622
SH40B	NT40	8000	77	Ø88.882	Ø66.7	M12xP1.75-4	180	170	Ø11-6	147	200	220	94	367	Ø35	20	16x5	45	Ø90	7002-623



# Flat End Movable Handle



**NEW**

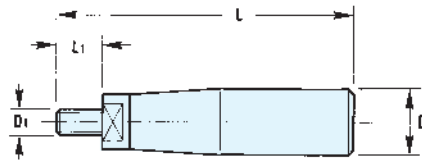

THREAD

## Flat End Movable Handle

- Handle is foggy plating treated.
- Detachable nut is blackened.
- Fit to common movable handwheel.
- Ready to use.
- Good handing.

ORDER NO.	D <sub>1</sub>	D	L <sub>1</sub>	L	CODE NO.
VFE-10	M10x1.5P	23	16	100	7003-001
VFE-83	3/8"x16	22	16	99	7003-002
VFE-8	M8x1.25P	19	16	93	7003-003
VFE-165	5/16"x18	19	10	78	7003-004

# Ellipse Movable Handle

**NEW**

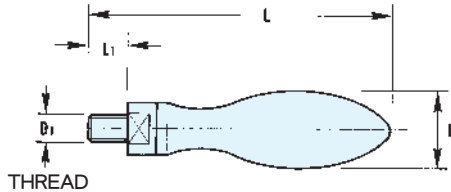

THREAD

## Ellipse Movable Handle

- Brilliant or foggy plating surface.
- Fit to common movable handwheel.
- Easy to install
- Shine and good looking.

ORDER NO.	D <sub>1</sub>	D	L <sub>1</sub>	L	CODE NO.
VEM-10	M10x1.5P	26	13	110	7003-007
VEM-83	3/8"x16	25	13	99	7003-008
VEM-8	M8x1.25P	20	9	80	7003-009
VEM-6	M6x1.0P	16	7	60	7003-010

# Ball Knobs

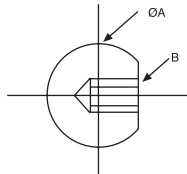

Name	Material	Surfaced process
Knob	Bakelite (KU)	Black

mm

ORDER NO. (KU)	A	B	CODE NO.
VKB-6AA	25	M6 x 1.0P	7003-120A
VKB-8A	25	M8 x 1.25P	7003-121A
VKB-8BA	38	M8 x 1.25P	7003-123A
VKB-10A	38	M10 x 1.5P	7003-124A
VKB-12AA	38	M12 x 1.75P	7003-127A
VKB-12BA	42	M12 x 1.75P	7003-128A

# Hand Knobs



THREAD

Name	Material	Surfaced process
Knob	(KT)	Black
Spindle	Steel (ST)	Zincing (ZI)

ORDER NO. (KT)	THREAD	Knob	CODE NO.
VKB-8K	M8x1.25Px21L	Ø40x65L	7003-133
VKB-8KL	M8x1.25Px63L	Ø40x65L	7003-134A

SPECIAL USAGE MACHINE

# Adjustable Hand Levers

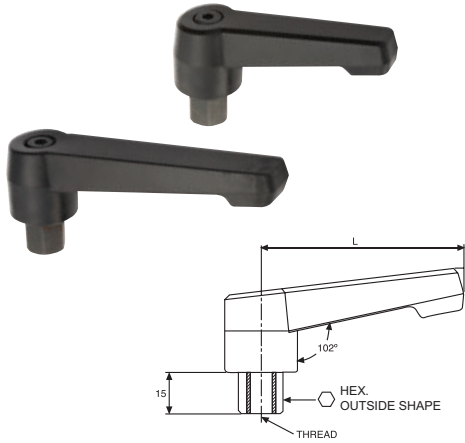

Name	Material	Surfaced process
Handle	Plastic (KT)	Black (BK) and black handle (OB)
Spindle	Steel (ST)	

mm

ORDER NO. (KT)	HANDLE L	THREAD	Hexagon	CODE NO.
VAH-6	42	M6	14	7003-214A
VAH-8	72	M8	14	7003-216A
VAH-10	92	M10	16	7003-217A
VAH-12	112	M12	16	7003-218A

# Adjustable Hand Levers

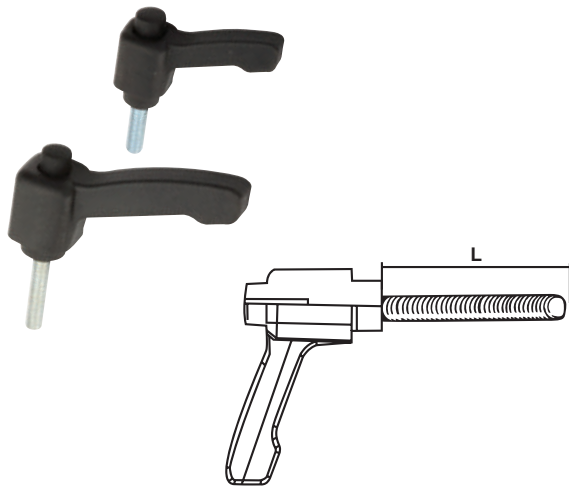

Name	Material	Surfaced process
Handle	(KT)	Black Knob
Spindle	Steel (ST)	

mm

ORDER NO. (KT)	THREAD L	HANDLE L	CODE NO.
VAH-620	M6x1.0Px20L	43	7003-220A
VAH-630	M6x1.0Px30L	43	7003-220B
VAH-640	M6x1.0Px45L	43	7003-220C
VAH-650	M6x1.0Px20L	63	7003-220D
VAH-6XL	M6x1.0Px30L	63	7003-220E
VAH-8D	M8x1.25Px30L	63	7003-222A
VAH-815	M8x1.25Px15L	83	7003-222B
VAH-840	M8x1.25Px40L	83	7003-222D
VAH-1020	M10x1.5Px20L	83	7003-223A

# Revolving Handles

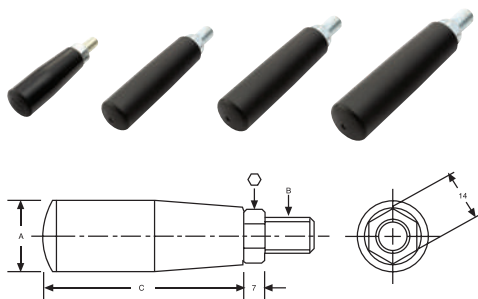

Name	Material	Surfaced process
Handle	Bakelite (KU)	Black
Spindle	Steel (ST)	Zincing (ZI)

mm

ORDER NO.	A	B	C	THREAD L	Hexagon	CODE NO.
VRL-8H	20	M8x1.25P	56	13	14	7003-283A
VRL-8HA	22	M8x1.25P	76	13	14	7003-284A
VRL-10H	20	M10x1.5P	56	13	14	7003-285A
VRL-10HA	22	M10x1.5P	76	13	14	7003-287A
VRL-10HB	25	M10x1.5P	83	13	14	7003-288A

# 360° Swivelling Lock Handle

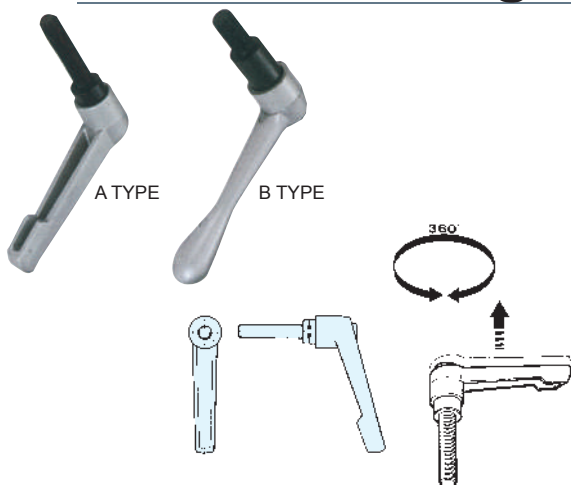

## 360° Swivel Handle

- When pull out, this handle can swivel 360° free.
- Aluminium handle, all water resistance.
- The handle shape features: curve, ball, square 3 types.

ORDER NO.	SIZE	CODE NO.
VSA-1	M6 x 1.0P x 30L	7003-300A
VSA-2	M8 x 1.25P x 30L	7003-301A
VSA-3	M10 x 1.5P x 30L	7003-302A
VSA-4	M12 x 1.75P x 30L	7003-302B
VSB-1	M6 x 1.0P x 30L	7003-303A
VSB-2	M8 x 1.25P x 30L	7003-304A
VSB-3	M10 x 1.5P x 30L	7003-305A
VSB-4	M12 x 1.75P x 30L	7003-305B

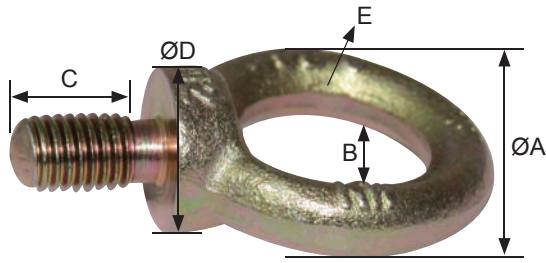

ORDER NO.	SIZE	ALLOWED LOAD (kg)	A	B	C	D	CODE NO.
VLE-6A	M6 x 1.0P	60	33	20	15	17	7003-321A
VLE-8A	M8 x 1.25P	80	34	20	15	17	7003-322A
VLE-10A	M10 x 1.5P	128	41	25	18	20	7003-323A
VLE-12A	M12 x 1.75P	187	50	30	20	25	7003-324A
VLE-14A	M14 x 2.0P	255	60	34	27	29	7003-325A
VLE-16A	M16 x 2.0P	383	60	35	28	30	7003-326A
VLE-18A	M18 x 2.5P	535	71	40	31	34	7003-327A
VLE-20A	M20 x 2.5P	535	71	40	31	35	7003-328A
VLE-22A	M22 x 2.5P	808	90	48	38	47	7003-329A
VLE-24A	M24 x 3.0P	808	92	50	38	47	7003-330A

# Shoulder Locating Unit

MOQ:1 BOX = 12 PCS

Unit : mm

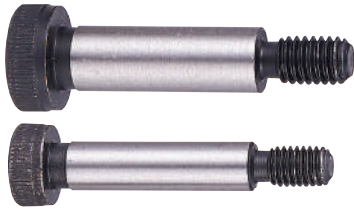

For lathe chuck

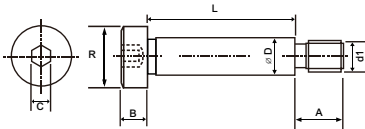

ORDER NO.	A±0.05	B±0.05	C	ØD	R	L	d1	WEIGHT KGS	CODE NO.
VLS-1320	11	5.5	4	MAX. 7.951 MIN. 7.987	13	20	M6 X 1.0P		7003-335
VLS-1325						25			7003-336
VLS-1330						30			7003-337
VLS-1335						35			7003-338
VLS-1340						40			7003-339
VLS-1620	13	7.0	5	MAX. 9.951 MIN. 9.987	16	20	M8 X 1.25P		7003-340
VLS-1625						25			7003-341
VLS-1630						30			7003-342
VLS-1635						35			7003-343
VLS-1640						40			7003-344
VLS-1820	16	8.0	6	MAX. 11.941 MIN. 11.984	18	20	M10 X 1.5P		7003-345
VLS-1825						25			7003-346
VLS-1830						30			7003-347
VLS-1835						35			7003-348
VLS-1840						40			7003-349

# Ring Plate

MOQ:1 BOX = 50 PCS

Unit : mm



ORDER NO.	SIZE D x d x T	BOX	WEIGHT KGS	CODE NO.
VLE-W226	Ø22 X Ø6.5 X 4 <sup>T</sup>	50 PCS		7003-353
VLE-W2210	Ø22 X Ø10.7 X 4 <sup>T</sup>	50 PCS		7003-354
VLE-W2511	Ø25 X Ø11.5 X 4 <sup>T</sup>	50 PCS		7003-355
VLE-W2512	Ø25 X Ø12.8 X 4 <sup>T</sup>	50 PCS		7003-356
VLE-W3212	Ø32 X Ø12.8 X 4 <sup>T</sup>	50 PCS		7003-357
VLE-W3215	Ø32 X Ø15.9 X 4 <sup>T</sup>	50 PCS		7003-358
VLE-W3515	Ø35 X Ø15.9 X 4 <sup>T</sup>	50 PCS		7003-359

# Crank Handle

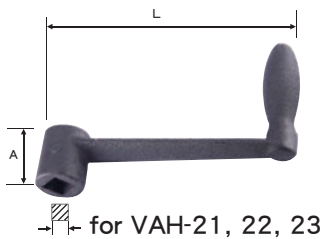

ORDER NO.	A	L	Ø	Weight kgs	CODE NO.
VAH-21	31	147	15	0.49	7003-460
VAH-22	41	183	16.5	0.64	7003-461
VAH-23	54	231	21	1.08	7003-462



ORDER NO.	A	L	Ø	Weight kgs	CODE NO.
VAH-31	37	180	14	0.48	7003-470
VAH-32	37	250	14	0.62	7003-471



# Ball Pluger Screw-Socket & Slotted



Material : SCM435 / 302HQ  
Hardness : HRC40 $\pm$ 3

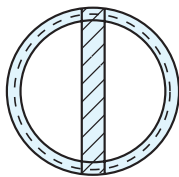

I TYPE  
SCREW DRIVER SL

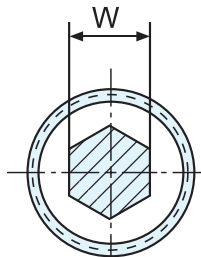

H TYPE  
HEX. SET TYPE

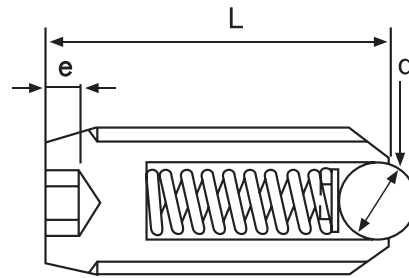

ORDER NO.	D	pitch	d	L	e	W	Light		Heavy		CODE NO.
							min	Max	min	Max	
VBP-03I	M3	0.5	1.5	7	1.0	1.5	1.0	2.0	1.5	2.9	7003-400A
VBP-04I	M4	0.7	2.5	9	1.5	2.0	2.0	4.9	3.9	9.8	7003-401A
VBP-05I	M5	0.8	3.0	12	2.0	2.5	2.9	9.8	4.9	19.6	7003-402A
VBP-06I	M6	1.0	3.5	13	2.5	3.0	4.9	14.7	9.8	29.4	7003-403A
VBP-08I	M8	1.25	5.0	15	2.5	4.0	6.9	19.6	12.7	39.2	7003-404A
VBP-10I	M10	1.5	6.0	16	3.0	5.0	8.8	24.5	18.6	49.0	7003-405A
VBP-12I	M12	1.75	8.0	22	3.0	6.0	9.8	29.4	19.6	58.8	7003-406A
VBP-16I	M16	2.0	10	25	3.0	8.0	15.7	49.0	29.4	98.0	7003-407A

VBP-03H	M3	0.5	1.5	7	1.0	1.5	1.0	2.0	1.5	2.9	7003-400B
VBP-04H	M4	0.7	2.5	9	1.5	2.0	2.0	4.9	3.9	9.8	7003-401B
VBP-05H	M5	0.8	3.0	12	2.0	2.5	2.9	9.8	4.9	19.6	7003-402B
VBP-06H	M6	1.0	3.5	13	2.5	3.0	4.9	14.7	9.8	29.4	7003-403B
VBP-08H	M8	1.25	5.0	15	2.5	4.0	6.9	19.6	12.7	39.2	7003-404B
VBP-10H	M10	1.5	6.0	16	3.0	5.0	8.8	24.5	18.6	49.0	7003-405B
VBP-12H	M12	1.75	8.0	22	3.0	6.0	9.8	29.4	19.6	58.8	7003-406B
VBP-16H	M16	2.0	10	25	3.0	8.0	15.7	49.0	29.4	98.0	7003-407B

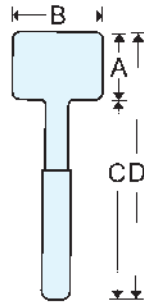

**BASIC:** Steel structure and include steel shot.  
**MATERIALS:** Main of the anti-pollution PU-liquid.  
 The holder use soft quality TPR.  
**FEATURE:** PU not make with heavy-metal and dioxin when burning.  
**HARDNESS:** Hardness of hammer (90A~95A)  
 Color may be varied.

ORDER NO.	A	B	C	D	Weight (g)	OZ	CODE NO.
VHM-38	38	100	249	287	490	18oz	7003-367
VHM-46	46	100	260	306	690	24oz	7003-368
VHM-50	50	110	290	340	930	33oz	7003-369
VHM-56	56	120	297	353	1160	41oz	7003-370
VHM-60	60	130	308	368	1370	49oz	7003-371

## Hammer

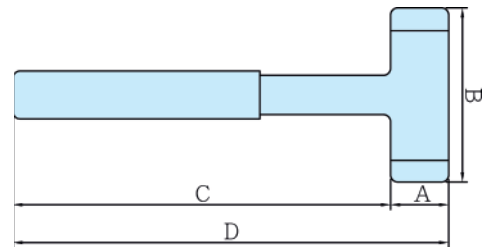

- Strike face uses UPE materials.
- Recyclable TPV holder.
- Strike face is inter-changeable

ORDER NO.	A	B	C	D	Weight (g)	OZ	CODE NO.
VHM-25PE	25	110	250	275	450	15oz	7003-380
VHM-30PE	30	110	250	280	480	16oz	7003-381
VHM-35PE	35	110	245	280	590	20oz	7003-382
VHM-40PE	40	120	260	300	850	29oz	7003-383
VHM-45PE	45	120	260	305	990	38oz	7003-384
VHM-50PE	50	125	265	315	1110	42oz	7003-385
VHM-55PE	55	135	265	320	1316	46oz	7003-386
VHM-60PE	60	140	265	320	1650	55oz	7003-387

### Hammer Head

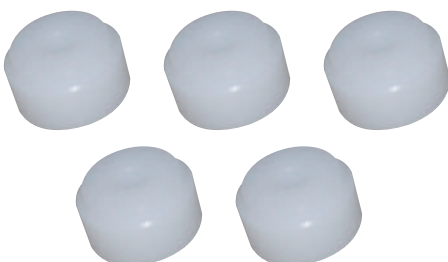

ORDER NO.	PIPE	CODE NO.
VHM-25H	25	7003-390
VHM-30H	30	7003-391
VHM-35H	35	7003-392
VHM-40H	40	7003-393
VHM-45H	45	7003-394
VHM-50H	50	7003-395
VHM-55H	55	7003-396
VHM-60H	60	7003-397



# Universal Drill & Cutter Grinder



ORDER NO.VDG-32N CODE NO.8001-010



Double cams: The cam of grinding drills & The cam of grinding taps.



## FEATURES

- Grinding capacity:  $\varnothing 1.5\sim\varnothing 32\text{mm}$  (Straight shank & taper shank) double wheels. It only need to rotate the motor when want to grind the tool of different material. It can increase the safety & save the time for changing & repairing the grinding wheel.
- The kinds of grinding tool include: drills, step drills, taps, lips of end mills, round bars, etc.
- Adopts precision 4" 6 jaws self-centering chuck, clipping one time. It can grind the blade of drills and do the paring of drills abdomen. The angle of drills both sides and the length of the blade are the same after grinding. It can keep the accuracy of the center of drills without off center.

### OPTIONAL:

VDG-32N-WHEEL-SDC  
145D #200

Longitudinal travel of table	120mm
Cross travel of saddle	135mm
Rotary angle of wheel head	360°
Point angle	90°-180°
Size of wheel	125x50x31.75mm
Speed of wheel	3600 RPM
Motor	3/4HP, 110V/220V/380V
N.W. / G.W.	90kgs/120kgs
Size of packing (LxWxH)	800x550x670mm



※ Guaranteed for 3 months

※ Color may vary



# Horizontal Band Saw

ORDER NO.HBS-7 CODE NO.8001-030



※ Please notify the voltage & phase when you ordering.

※ Color may vary

## SPECIFICATION

Capacity	●180mm (7") ■180x300mm (7"x12")
Blade size	19x0.9x2360mm (3/4"x0.32x7'9")
Motor	1HP 4pole 50HZ/1430rpm; 60HZ/1720rpm
Blade speed	22, 33, 45, 65mpm (86-132-178-260fpm)
Machine dim	L1470xW430mm (L58"xW17") H990mm (39") horizontal position.
N.W.	130kgs (286LBS)
G.W.	150kgs (341LBS)
Voltage	220V/3PH ,380V/3PH



# Horizontal Band Saw

ORDER NO.HBS-7CE CODE NO.8001-030CE



CE STANDARD

※Please notify the voltage & phase when you ordering.

※Color may vary

## SPECIFICATION

Capacity	90° ● 180mm ■ 180x280mm ■ 65x300mm 45° ● 110mm ■ 180x110mm
Blade size	19x0.9x2360mm
Motor	1HP 4pole 50HZ/1430rpm; 60HZ/1720rpm
Blade speed	Step pulley 22, 33, 45, 65mpm
Packing Measurement	1295x457x1028mm
N.W. / G.W.	130kgs/150kgs
Type	"CE" Standard
Voltage	380V/3PH



# Saw Blade

**NEW**



※FOR VERTICAL G14 & HBS-7 BAND SAW

ORDER NO.	MATERIAL	THICKNESS	W	L (mm)	T	MACHINE TYPE	CODE NO.
HBS-106	CARBON STEEL	0.65	6	30000	14	Y-310 Y-360 Y-400 Y-500 .....ETC.	8001-700
HBS-108	CARBON STEEL	0.65	8	30000	14		8001-701
HBS-110	CARBON STEEL	0.65	10	30000	14		8001-702

ORDER NO.	MATERIAL	THICKNESS	W	L (mm)	T	MACHINE TYPE	CODE NO.
HBS-126	HSS	0.65	6	15000	10 / 14	Y-310 Y-360 Y-400 Y-500 .....ETC.	8001-710
HBS-128	HSS	0.65	10	15000	10 / 14		8001-711

ORDER NO.	MATERIAL	THICKNESS	W	L (mm)	T	MACHINE TYPE	CODE NO.
HBS-131	HSS	0.65	13	1470	10/14	UE-100S	8001-720
HBS-132	HSS	0.9	27	3035	4/6	HBS-9	8001-721

ORDER NO.	MATERIAL	THICKNESS	W	L (mm)	T	MACHINE TYPE	CODE NO.
HBS-7-BLADE-HSS	HSS	0.9	19	2365	5/8P	HBS-7	8001-730
HBS-7-BLADE-CARBIDE	CARBIDE	0.9	19	2365	8P	HBS-7	8001-731

SPECIAL USAGE MACHINE



AIR INLET 1/4"

AIR PRESSURE 90 PSI

DIY type

ORDER NO. VAG-500

Economic type

ORDER NO. VAG-601A



VAG-500



VAG-601A

turbine oil #60

※ Guaranteed for 3 months

- Clean & Dry Air Needed.
- Fixed Type Collet Chuck:  $\varnothing 3.0\text{mm}$  Is Standard. 3/32" & 1/8" Collet Are Available Upon Your Request. Put Oil 10 C.C. Into The Air Inlet Hole Twice Daily.
- It's Warm When It's Working.
- Reliable Quality And Economic Price.

※ OPTIONAL

ORDER NO.	COLLET	CODE NO.
VAG-500-3MM	3mm	8001-099A
VAG-500-3/32"	3/32"	8001-099B
VAG-500-1/8"	1/8"	8001-099C
VAG-601A-COLLET 3MM	3mm	8001-100A
VAG-601A-COLLET 3/32"	3/32"	8001-100B
VAG-601A-COLLET 1/8"	1/8"	8001-100C

ORDER NO.	COLLET SIZE	SPEED	WEIGHT (g)	LENGTH	CODE NO.
VAG-500	3mm, 3/32", 1/8"	54,000 R.P.M.	130	150mm	8001-099
VAG-601A	3mm, 3/32", 1/8"	54,000 R.P.M.	130	150mm	8001-100

### Strong & silent type



turbine oil #60

※ Guaranteed for 3 months

- Replaceable collet chuck:  $\varnothing 3.0\text{mm}$  is standard. 3/32" and 1/8" collet are available upon your request.
- High-torque, quiet-running and well balance.
- Ideal for finishing works.

※ OPTIONAL

ORDER NO.	COLLET	CODE NO.
VAG-701-3MM	3mm	8001-101A
VAG-701-3/32"	3/32"	8001-101B
VAG-701-1/8"	1/8"	8001-101C

ORDER NO.	COLLET SIZE	SPEED	WEIGHT (g)	LENGTH	CODE NO.
VAG-701	3mm, 3/32", 1/8"	70,000 R.P.M.	620	150mm	8001-101

### Dual-collet type



turbine oil #60

※ Guaranteed for 3 months

- Dual collet chuck:  $\varnothing 3.0\text{mm}$  and  $\varnothing 6.0\text{mm}$  are standard. 1/8" and 1/4" collet are available upon your request.
- High torque, heavy-duty, general-purpose applicable on deburring, chamfering, milling and finishing the welded surface etc.

※ OPTIONAL

ORDER NO.	COLLET	CODE NO.
VAG-609-3MM	3mm	8001-115A
VAG-609-6MM	6mm	8001-115B
VAG-609-1/4"	1/4"	8001-115C
VAG-609-1/8"	1/8"	8001-115D

ORDER NO.	COLLET SIZE	SPEED	WEIGHT (g)	LENGTH	CODE NO.
VAG-609	3mm, 6mm	35,000 R.P.M.	530	175mm	8001-115

### Angle 45° type

- Angle 45°, suitable for angle deburring and finishing.



turbine oil #60

※ Guaranteed for 3 months

※ OPTIONAL

ORDER NO.	MATERIAL	CODE NO.
VAG-8241-WF-30P-PAD	PAD	8001-116A
VAG-8241-WF-30S-SAND-40	GRADE #40, pcs/100/BOX	8001-116B
VAG-8241-WF-30S-SAND-60	GRADE #60, pcs/150/BOX	8001-116C
VAG-8241-WF-30C-WHEEL	GRADE #60	8001-116D

ORDER NO.	WHEEL SIZE	SPEED	WEIGHT (g)	LENGTH	CODE NO.
VAG-8241	$\varnothing 30\text{mm}$	23,000 R.P.M.	300	160mm	8001-116



## Economic type



turbine oil #60

※ Guaranteed for 3 months

ORDER NO.	COLLET SIZE	SPEED	WEIGHT (g)	LENGTH	CODE NO.
VAG-604	6mm, 1/4"	22,000 R.P.M.	600	175mm	8001-117

※ All air tool need to add air tool oil & maintaine every 3 months.

- Fixed type collet chuck:  $\phi 6.0\text{mm}$  is standard. 1/4" collet is available upon your request.
- Reliable quality and economic price.

### ※ OPTIONAL

ORDER NO.	COLLET	CODE NO.
VAG-604-6MM	6mm	8001-117A
VAG-604-1/4"	1/4"	8001-117B

## Strong & silent type



turbine oil #60

※ Guaranteed for 3 months

ORDER NO.	COLLET SIZE	SPEED	WEIGHT (g)	LENGTH	CODE NO.
VAG-605	6mm, 3mm	25,000 R.P.M.	520	150mm	8001-118

- Replaceable collet chuck:  $\phi 3\text{mm}$   $\phi 6\text{mm}$  are standard. 1/4" collet is available upon your request.
- High-torque, quite-running and well balance.
- Ideal for finishing works.

### ※ OPTIONAL

ORDER NO.	COLLET	CODE NO.
VAG-605-3MM	3mm	8001-118A
VAG-605-6MM	6mm	8001-118B
VAG-605-1/4"	1/4"	8001-118C

## Angle 90° type

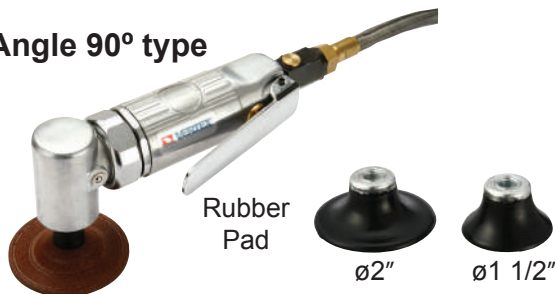

turbine oil #60

※ Guaranteed for 3 months

ORDER NO.	PAD SIZE	SPEED	WEIGHT (g)	LENGTH	CODE NO.
VAG-8242	50mm	16,000 R.P.M.	520	175mm	8001-119

- $\phi 1\ 1/2"$  or  $\phi 2"$  rubber pad with quick change abrasive are additional options. (extra charge)
- High torque, heavy-duty, general-purpose applicable on deburring, chamfering, milling and finishing the welded surface.
- 2" wheel is standard.

### ※ OPTIONAL

ORDER NO.	COLLET	CODE NO.
VAG-8242-PAD-1-1/2	1 1/2"	8001-119A
VAG-8242-PAD-2	2"	8001-119B

## 4" Angle tool



turbine oil #60

※ Guaranteed for 3 months

ORDER NO.	WHEEL SIZE	SPEED	WEIGHT (g)	LENGTH	CODE NO.
VAG-932	100mm, (4")	11,000 R.P.M.	1350	175mm	8001-120

AIR TOOL

**CAUTIONS:**

1. AIR COMPRESSOR PRESSURE 6~8 kg/cm<sup>2</sup> , DRY AIR.
2. Always check oil level of the 3 in 1 air combination.
3. Tapping ARM has to be mounted on the same hardened work plate.
4. SET THE WORKPIECE SURFACE TO BE PARALLELED WITH TAPPING ARM STAND.
5. Always supply cutting oil while tapping.
6. Work every 1 hour rest 10 to 15 minutes, 8 hours per day. Every 3 months need service.
7. After use, drop some #60 oil/lubrication into air inlet. Air hose & connector must be cleaned before use!

- Angle 90°, suitable for angle deburring and finishing.

### ※ OPTIONAL

ORDER NO.	SIZE	CODE NO.
VAG-932-WHEEL	4"	8001-120A

## Air file



turbine oil #60

※ Guaranteed for 3 months

※ All air tool need to add air tool oil & maintaince every 3 months.

- Also suitable for shoes, molds, and wooden processes.
- Can grind metals. Especial suitable for narrow parts or groove bases & sides.

※ **OPTIONAL**

ORDER NO.	QUANTITY	CODE NO.
VAG-318-FILE SET	4 pcs/SET	8001-121A

ORDER NO.	COLLET SIZE	SPEED	Stroke	WEIGHT (g)	LENGTH	CODE NO.
VAG-318	6mm	3,700 cycle/min	9mm	1,250	175mm	8001-121

## Finger sander



turbine oil #60

※ Guaranteed for 3 months

- It is the speed and has beautiful finishing. Suit for the corners and complicated curves.
- Can provide the smooth and high-speed eccentric rotation movement and easy replacement without file any special tools.

※ **OPTIONAL**

ORDER NO.	MATERIAL	CODE NO.
VAG-F30-PAD-THIN	THIN	8001-122A
VAG-F30-VISCID-THICK	THICK	8001-122B
VAG-F30-VISCID-THIN	THIN	8001-122C
VAG-F30-STEEL-PLATE	PLATE	8001-122D

ORDER NO.	SIZE	SPEED	WEIGHT (g)	LENGTH	CODE NO.
VAG-F30	Abrasive: W20mm	13,000 R.P.M.	830	200mm	8001-122

## Belt Sander

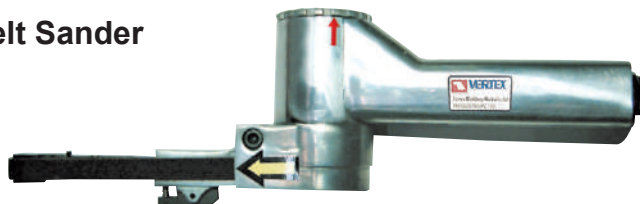

turbine oil #60

※ Guaranteed for 3 months

- For sanding curved surfaces, flat surfaces.
- For removing spot welding, semi & automatic welds, adhesive, paint, and other coating in concave places.

※ **OPTIONAL**

ORDER NO.	GRADE	CODE NO.
VAG-310-BELT	#100	8001-123A

ORDER NO.	SIZE	SPEED	WEIGHT (g)	LENGTH	CODE NO.
VAG-310	10x330mm	16,000 R.P.M.	800	290mm	8001-123

## Belt Sander



turbine oil #60

※ Guaranteed for 3 months

- For sanding curved surfaces, flat surfaces.
- For removing spot welding, semi & automatic welds, adhesive, paint, and other coating in concave places.

※ **OPTIONAL**

ORDER NO.	GRADE	CODE NO.
VAG-320-BELT	#100	8001-124A

ORDER NO.	BELT SIZE	SPEED	WEIGHT (g)	LENGTH	CODE NO.
VAG-320	20x520mm	16,000 R.P.M.	1100	360mm	8001-124



# Air Die Tool



## AIR LAPPERS

**NEW**



- For Ø3.0mm shank.
- Suits for detail area's lapping.
- Low noise, low vibration and durable tool life.
- Dry air only.
- Light duty.
- Turbo type.
- Driven by turbine air motor.

※ Guaranteed for 3 months

ORDER NO.	STROKE	SPEED	DIMENSIONS	WEIGH(g)	CODE NO.
VAG-030	0.3mm	28,000 r.p.m.	Ø28 x 200 mm	220	8001-126

※ All case box are not under warranty.



# Air Die Tool

## AIR LAPPERS

**NEW**



- For Ø3.0mm shank.
- Features in efficiency polishing and deburring & chamfering work.
- Extra high speed.
- Light duty.
- Ultra type.
- Dry air only.

※ Guaranteed for 3 months

ORDER NO.	STROKE	SPEED	DIMENSIONS	WEIGH(g)	CODE NO.
VAG-050	0.5mm	45,000 r.p.m.	Ø23 x 185 mm	220	8001-127

※ All case box are not under warranty.



# Air Die Tool

## AIR LAPPERS

**NEW**



- For Ø3.0mm shank.
- Side to side stroke.
- Special design enable the easiest way to change parts.
- Suit for filing, lapping and polishing shallow surfaces, deep and parting lines.
- Light duty.
- Swing type.
- Dry air only.

※ Guaranteed for 3 months

ORDER NO.	STROKE	SPEED	DIMENSIONS	WEIGH(g)	CODE NO.
VAG-070	0.7mm	15,000 r.p.m.	Ø28 x 205 mm	305	8001-128

※ All case box are not under warranty.



# Air Die Tool

## AIR LAPPERS

**NEW**



- For Ø3.0mm shank.
- Suits for general purpose polishing and finishing process of mold and die.
- Low noise, low vibration and durable life.
- Driven by turbine air motor.
- Turbo type.
- Light duty.
- Dry air only.

※ Guaranteed for 3 months

ORDER NO.	STROKE	SPEED	DIMENSIONS	WEIGH(g)	CODE NO.
VAG-070H	0.7mm	28,000 r.p.m.	Ø28 x 200 mm	220	8001-129

※ All case box are not under warranty.



# Abrasive Mounted Point & Wheel For Air Tool



## Emery Wheel

- The shank size is  $\varnothing 3.0$
- The wheel size is  $\varnothing D$
- The minimum quantity is 100 pcs / each

### ABRASIVE MOUNTED POINTS

WA PIN WITH ELASTICITY  
CERAMIC WHEEL  
APPLICATIONS:FOR METAL  
SURFACE POLISHING



ORDER NO.	WA-303A	WA-304A	WA-305A
$\varnothing D$	3mm	4mm	5mm
CODE NO.	8001-131	8001-132	8001-133

ORDER NO.	WA-306A	WA-308A	WA-310A
$\varnothing D$	6mm	8mm	10mm
CODE NO.	8001-134	8001-135	8001-136

### FELT BOBS

WF PIN WITH FELT WHEEL  
APPLICATIONS:FOR METAL  
SURFACE POLISHING

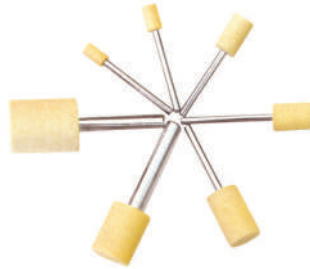

ORDER NO.	WF-304	WF-305	WF-306
$\varnothing D$	4mm	5mm	6mm
CODE NO.	8001-137	8001-138	8001-139

ORDER NO.	WF-308	WF-310	WF-312
$\varnothing D$	8mm	10mm	12mm
CODE NO.	8001-140	8001-141	8001-142

### RUBBERIZE POINTS

120GRIT  
WR PIN WITH ELASTICITY  
SPONGE WHEEL  
APPLICATIONS:FOR METAL  
SURFACE POLISHING

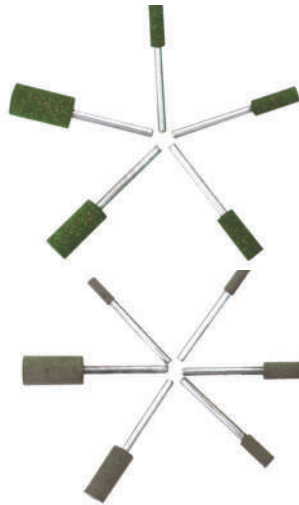

ORDER NO.	WR-304	WR-305
$\varnothing D$	4mm	5mm
CODE NO.	8001-144	8001-145

ORDER NO.	WR-306	WR-308	WR-310
$\varnothing D$	6mm	8mm	10mm
CODE NO.	8001-146	8001-147	8001-148

### RESINOID POINTS

120GRIT  
WE PIN WITH ELASTICITY R  
POLISHING WHEEL  
APPLICATIONS:FOR METAL  
SURFACE POLISHING

ORDER NO.	WE-303	WE-304	WE-305
$\varnothing D$	3mm	4mm	5mm
CODE NO.	8001-149	8001-150	8001-151

ORDER NO.	WE-306	WE-308	WE-310
$\varnothing D$	6mm	8mm	10mm
CODE NO.	8001-152	8001-153	8001-154

### RUBBERI PAD

$\varnothing 30mm$



ORDER NO. WF-30P  
CODE NO. 8001-155

### PAPER DISC

$\varnothing 30mm$   
GRIT100  
150 PCS/BOX  
Packed



ORDER NO. WF-30S  
CODE NO. 8001-156

### CUP WHEEL

$\varnothing 30mm$   
GRIT60  
40 PCS/BOX  
Packed



ORDER NO. WF-30C  
CODE NO. 8001-157



## Handy Sponge Sander



VSS-436

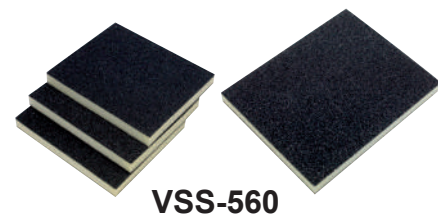

VSS-560

### Features:

- Convenient
- All purpose
- Square shape : easy to handle
- Remove iron rust or scratches & unevenness
- Good for round edges and corners
- Final sanding of a flat surface
- Good for fine sanding or paint removal
- Great for sanding narrow spaces & uneven surface
- MOQ : 1BOX=24 PCS

ORDER NO.	DIMENSIONS (mm)	Available Grit			WEIGHT kgs	CODE NO.
		36 coarse	60 medim	100 fine		
VSS-436	100 x 70 x 25 36 <sup>#</sup>	35				8001-220
VSS-460	100 x 70 x 25 60 <sup>#</sup>		35			8001-221
VSS-4100	100 x 70 x 25 100 <sup>#</sup>			35		8001-222
VSS-560	125 x 98 x 13 60 <sup>#</sup>		35			8001-223
VSS-5100	125 x 98 x 13 36 <sup>#</sup>			35		8001-224



# Diamond Tools For Air Tool



ORDER NO. WG-30D CODE NO. 8001-160

Diamond mounted points (3.0 shank)

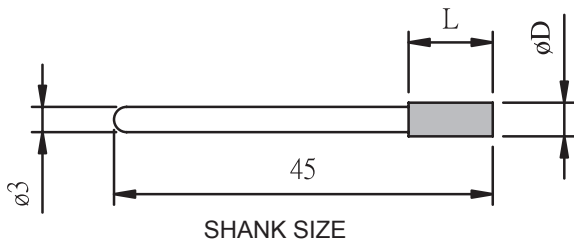
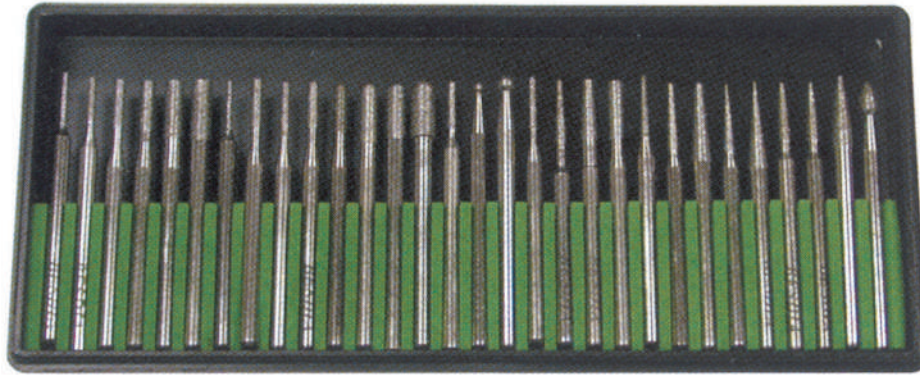

WG-30D: 30 PCS / set  
 (set in ø3.0 mm shank)  
 WG-30D-I: 30 PCS / set  
 (set in ø1/8" shank)  
 Weight: 0.1 kgs

Grit size:  
 ø2.0~ø5.0 is 120#  
 ø1.0~ø1.5 is 150#,  
 one set including all  
 point each one,  
 total is 30 pcs/set

30 PCS ASSORTMENT SET: CONTAINS ONE EACH OF ABOVE POINTS.

Unit:mm

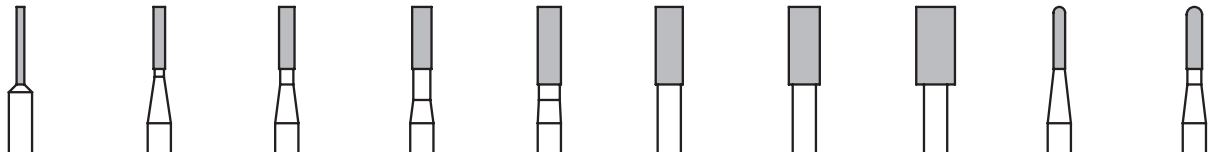

ORDER NO.	10A	15A	20A	25A	30A	35A	40A	50A	15C	20C
ØD	Ø1	Ø1.5	Ø2	Ø2.5	Ø3	Ø3.5	Ø4	Ø5	Ø1.5	Ø2
L	8	8	8	8	10	10	10	10	8	8
CODE NO.	8001-161	8001-162	8001-163	8001-164	8001-165	8001-166	8001-167	8001-168	8001-169	8001-170

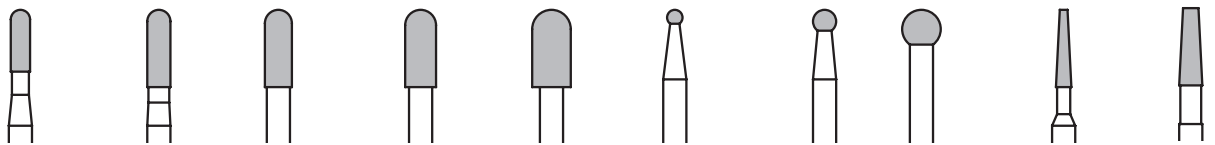

ORDER NO.	25C	30C	35C	40C	50C	20B	30B	50B	20T	30T
ØD	Ø2.5	Ø3	Ø3.5	Ø4	Ø5	Ø2	Ø3	Ø5	Ø2	Ø3
L	8	10	10	10	10	-	-	-	10	10
CODE NO.	8001-171	8001-172	8001-173	8001-174	8001-175	8001-176	8001-177	8001-178	8001-179	8001-180

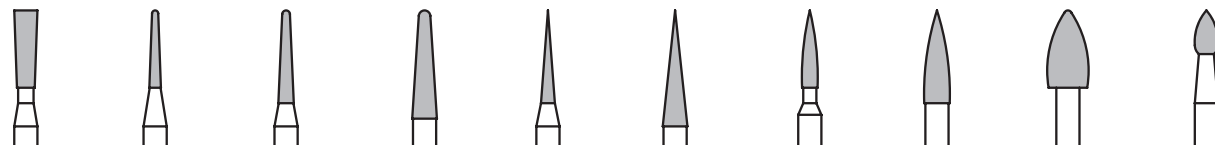

ORDER NO.	30V	15R	20R	30R	20P	30P	20F	30F	50F	30S
ØD	Ø3	Ø1.5	Ø2	Ø3	Ø2	Ø3	Ø2	Ø3	Ø5	Ø3
L	10	10	12	14	12	15	10	10	10	6
CODE NO.	8001-181	8001-182	8001-183	8001-184	8001-185	8001-186	8001-187	8001-188	8001-189	8001-190

SPECIAL USAGE MACHINE



# Carbide Rotary Burrs



CYLINDER ROUND NOSE

NEW

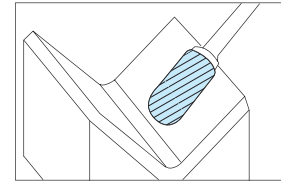
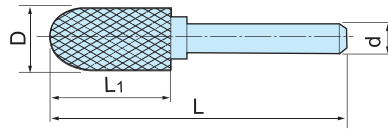

Unit : mm

ORDER NO.	D	R	L	L1	d	WEIGHT(g)	CODE NO.
VRB-C6	6	3.0R	65	16	6	0.02	8001-301
VRB-C8	8	4.0R	65	20	6	0.03	8001-302
VRB-C10	10	5.0R	65	20	6	0.03	8001-303
VRB-C12	12	6.0R	65	25	6	0.04	8001-304



# Carbide Rotary Burrs

NEW

SPHERE

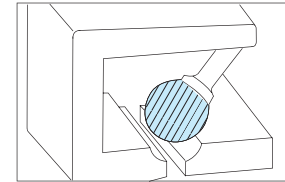
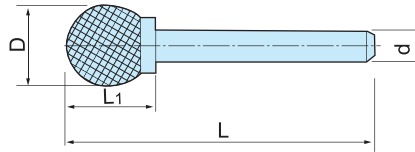

Unit : mm

ORDER NO.	D	L	L1	d	WEIGHT(g)	CODE NO.
VRB-S6	6	55	5	6	0.02	8001-311
VRB-S8	8	65	7	6	0.03	8001-312
VRB-S10	10	65	9	6	0.03	8001-313
VRB-S12	12	65	10	6	0.04	8001-314



# Carbide Rotary Burrs

ARCH ROUND NOSE

NEW

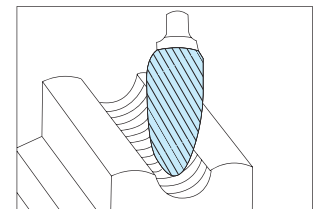
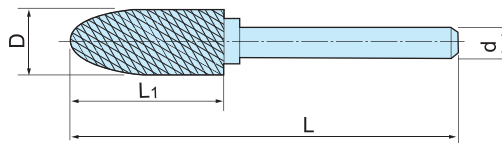

Unit : mm

ORDER NO.	D	R	L	L1	d	WEIGHT(g)	CODE NO.
VRB-A6	6	1.5R	65	18	6	0.02	8001-321
VRB-A8	8	2R	65	20	6	0.03	8001-322
VRB-A10	10	2.5R	65	20	6	0.03	8001-323
VRB-A12	12	3R	65	25	6	0.04	8001-324

# Carbide Rotary Burrs



## ARCH POINT NOSE

NEW

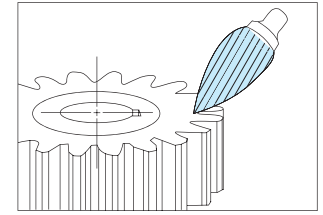
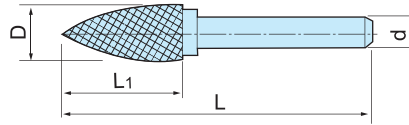

Unit : mm

ORDER NO.	D	R	L	L1	d	WEIGHT(g)	CODE NO.
VRB-P6	6	26R	65	18	6	0.02	8001-331
VRB-P8	8	27R	65	20	6	0.03	8001-332
VRB-P10	10	28R	65	20	6	0.03	8001-333
VRB-P12	12	30R	65	25	6	0.04	8001-334

# Carbide Rotary Burrs

## CONE WITH ROUND NOSE

NEW

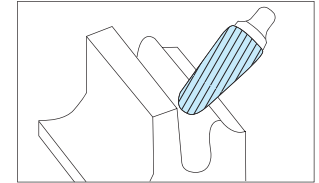
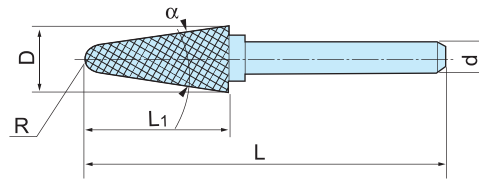

Unit : mm

ORDER NO.	D	R	L	L1	d	$\alpha$	WEIGHT(g)	CODE NO.
VRB-CR6	6	1.2R	65	16	6	14°	0.02	8001-341
VRB-CR8	8	1.4R	65	22	6	14°	0.03	8001-342
VRB-CR10	10	2.2R	65	25	6	14°	0.03	8001-343
VRB-CR12	12	3.0R	80	28	6	14°	0.04	8001-344

# Carbide Rotary Burrs

## CONE WITH ROUND NOSE

NEW

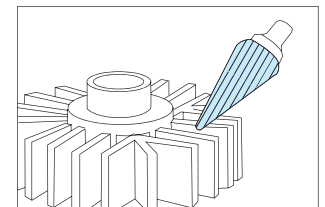
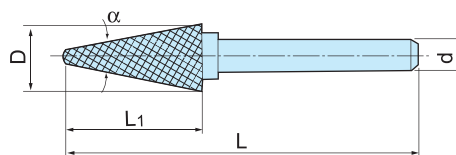

Unit : mm

ORDER NO.	D	L	L1	d	$\alpha$	WEIGHT(g)	CODE NO.
VRB-PC6	6	65	18	6	14°	0.02	8001-351
VRB-PC8	8	65	20	6	20°	0.03	8001-352
VRB-PC10	10	65	20	6	25°	0.03	8001-353
VRB-PC12	12	65	25	6	25°	0.04	8001-354

SPECIAL USAGE MACHINE